

CATALOGUE No.  
**KG5001EN**

# **KG STOCK GEARS**

## **Metric Gears**



EN CATALOG



EN 2D 3D CAD

**KG** 協育齒車工業株式会社

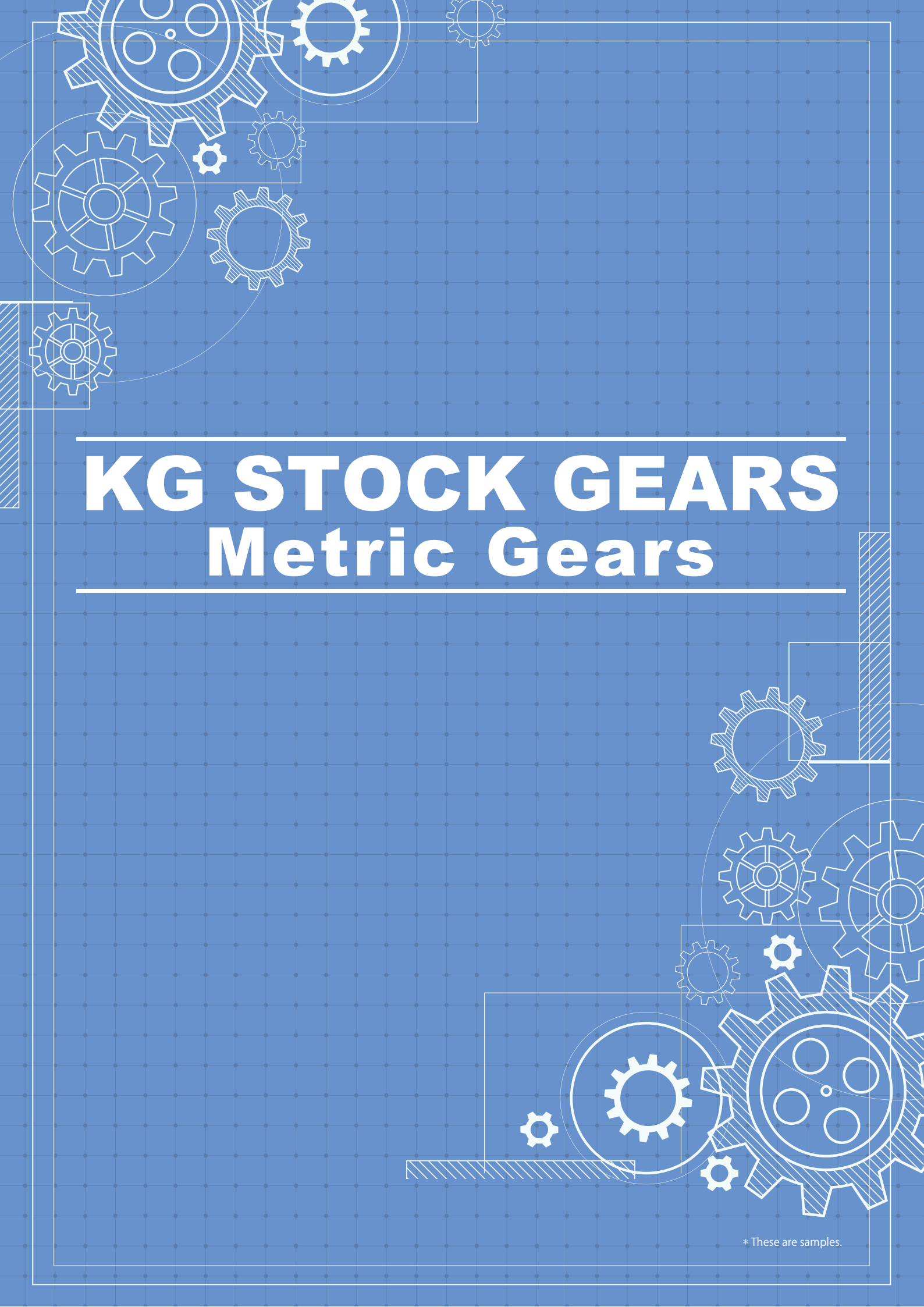

# KG STOCK GEARS

## Metric Gears

\* These are samples.

# KG STOCK GEARS

*Gears for Every Need.....*



URL <https://www.kggear.co.jp/en/>

## Greetings

Thank you for your patronage.

We are proud to publish our new catalogue series KG STOCK GEARS KG4000.

KG STOCK GEARS has anticipated various needs from our customers.

The products we have been offering from our founding. The products we had released with cutting-edge technology. I believe both of our products are the monument of customers' needs.

Offering nearly 2,700 products anytime, anywhere, and timely, with stable quality has been our credo from the beginning.

I hope you make full use of our featured KG STOCK GEARS.

Representative Director **Tadaaki Ida**

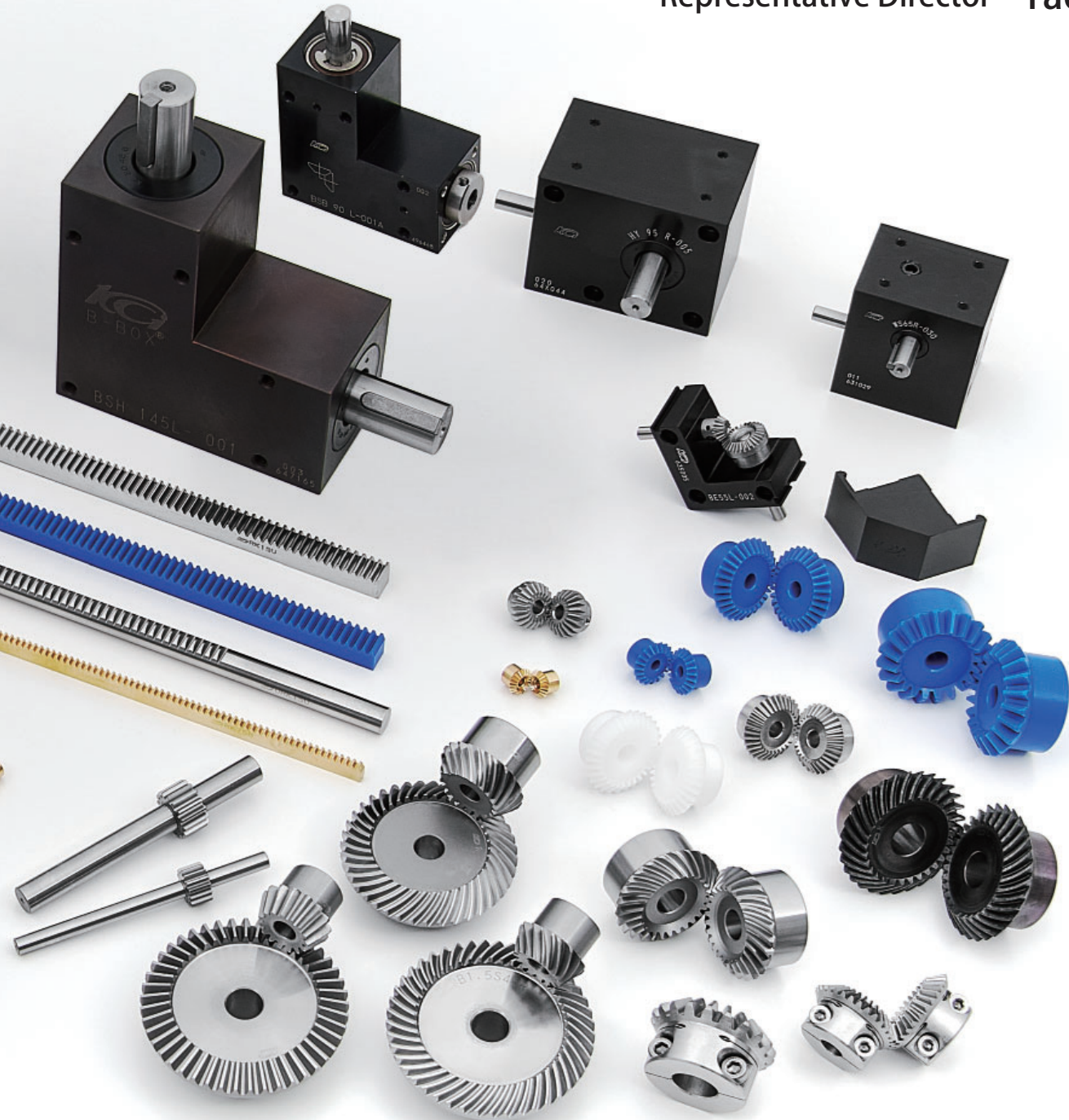

**The Contents of KG-General Catalogue.**

Information of KG STOCK GEARS

Edition of Dimensions

# Product page introduction

## ② Goods image

## ① Basic information

Series code, Material, Gear type, Module, Tooth profile

## ③ Simple dimension symbol diagram

## ⑦ 2D,3D CAD download URL

**S Spur (S45C) Module 0.5 (Full Depth Tooth)**

B1 type [-] B1 type [+]

**S Spur (S45C) Module 0.5 (Full Depth Tooth)**

K1 type K2 type [-]

Unit: mm

Accuracy Class	Material	Pressure angle	Heat treatment	Tooth surface hardness	Backlash (1)
[JIS B 1702-1] NB	S45C	20°	—	—	0.02 to 0.06

\* No surface treatment is applied. (1) Two screw holes and set screws are provided.  
 \* This allowable transfer capability table was prepared by using the formulas presented by the JGMA (Japan Gear Manufacturers Association). For the unit conversion method, refer to P. 20 in "References."  
 (1) This is a theoretical value obtained when a pair of gears of the same type and material are meshed with each other.

Catalogue number	Number of teeth	Reference diameter	Tip diameter	Type	Face width	Hole diameter	Hub diameter	Hub length	Overall length	Screw		Weight
										2-M(120°)	l	
S505 10K - 1006	10	φ 5	φ 6	K1	10	-	φ 6	45	55	-	-	11.5
S505 12K - 1007	12	φ 6	φ 7	K1	10	-	φ 7	45	55	-	-	15.8
S505 15K * 0803	15	φ 7.5	φ 8.5	K2	8	φ3(H8)	φ 8.5	10	18	2-M3	3	6.0
S505 16K * 0803	16	φ 8	φ 9	K2	8	φ3(H8)	φ 9	10	18	2-M3	3	6.9
S505 18K * 0804	18	φ 9	φ 10	K2	8	φ4(H8)	φ 10	10	18	2-M3	3	8.1
S505 20K * 0804	20	φ 10	φ 11	K2	8	φ4(H8)	φ 11	10	18	2-M3	3	10.3
S505 22K * 0804	22	φ 11	φ 12	K2	8	φ4(H8)	φ 12	10	18	2-M3	3	12.7
S505 24K * 0804	24	φ 12	φ 13	K2	8	φ4(H8)	φ 13	10	18	2-M3	3	15.4
S505 25B * 0804	25	φ 12.5	φ 13.5	B1	8	φ4(H8)	φ 10	8	16	2-M3	4	10.8
S505 26B * 0804	26	φ 13	φ 14	B1	8	φ4(H8)	φ 10	8	16	2-M3	4	11.4
S505 28B * 0804	28	φ 14	φ 15	B1	8	φ4(H8)	φ 10	8	16	2-M3	4	12.8
S505 30B * 0805	30	φ 15	φ 16	B1	8	φ5(H8)	φ 12	8	16	2-M3	4	15.4
S505 32B * 0505	32	φ 16	φ 17	B1	5	φ5	φ 12	8	13	2-M3	4	12.7
S505 35B * 0505	35	φ 17.5	φ 18.5	B1	5	φ5	φ 12	8	13	2-M3	4	14.2
S505 36B * 0505	36	φ 18	φ 19	B1	5	φ5	φ 12	8	13	2-M3	4	14.8
S505 40BF - 0504	40	φ 20	φ 21	B1	5	φ4(H8)	φ 15	8	13	-	-	22.1
S505 40B * 0505	40	φ 20	φ 21	B1	5	φ5	φ 15	8	13	2-M3	4	21.0
S505 42 * 0505	42	φ 21	φ 22	B1	5	φ5	φ 15	8	13	2-M3	4	22.3
S505 44B * 0505	44	φ 22	φ 23	B1	5	φ5	φ 15	8	13	2-M3	4	23.6
S505 45B * 0505	45	φ 22.5	φ 23.5	B1	5	φ5	φ 15	8	13	2-M3	4	24.3
S505 48B * 0505	48	φ 24	φ 25	B1	5	φ5	φ 15	8	13	2-M3	4	26.4
S505 50B * 0505	50	φ 25	φ 26	B1	5	φ5	φ 15	8	13	2-M3	4	27.9
S505 52B * 0505	52	φ 26	φ 27	B1	5	φ5	φ 15	8	13	2-M3	4	29.5
S505 54B * 0505	54	φ 27	φ 28	B1	5	φ5	φ 15	8	13	2-M3	4	31.1
S505 55B * 0505	55	φ 27.5	φ 28.5	B1	5	φ5	φ 15	8	13	2-M3	4	32.0
S505 56B * 0505	56	φ 28	φ 29	B1	5	φ5	φ 15	8	13	2-M3	4	32.8
S505 60B * 0506	60	φ 30	φ 31	B1	5	φ6	φ 18	8	13	2-M4	4	39.9
S505 64B * 0506	64	φ 32	φ 33	B1	5	φ6	φ 18	8	13	2-M4	4	43.7
S505 70B * 0506	70	φ 35	φ 36	B1	5	φ6	φ 18	8	13	2-M4	4	49.9
S505 72B * 0506	72	φ 36	φ 37	B1	5	φ6	φ 18	8	13	2-M4	4	52.1
S505 75B * 0506	75	φ 37.5	φ 38.5	B1	5	φ6	φ 18	8	13	2-M4	4	55.5
S505 80BF - 0506	80	φ 40	φ 41	B1	5	φ6	φ 28	8	13	-	-	85.0
S505 80B * 0508	80	φ 40	φ 41	B1	5	φ8	φ 22	8	13	2-M4	4	67.0
S505 90B * 0508	90	φ 45	φ 46	B1	5	φ8	φ 22	8	13	2-M4	4	80.1
S505 96B * 0508	96	φ 48	φ 49	B1	5	φ8	φ 22	8	13	2-M4	4	88.7

Catalogue number	Number of teeth	Reference diameter	Tip diameter	Type	Face width	Hole diameter	Hub diameter	Hub length	Overall length	Screw		Weight
										2-M(120°)	l	
S505 100B * 0508	100	φ 50	φ 51	B1	5	φ 8	φ 25	8	13	2-M4	4	101.4
S505 110B * 0508	110	φ 55	φ 56	B1	5	φ 8	φ 25	8	13	2-M4	4	117.6
S505 120B * 0508	120	φ 60	φ 61	B1	5	φ 8	φ 25	8	13	2-M4	4	135.4

Allowable transfer capability table for different revolutions per minute, Bending strength. (Unit: W)

Catalogue number	Bending strength						
	10rpm	100rpm	200rpm	400rpm	800rpm	1,200rpm	1,500rpm
S505 10K - 1006	0.62	6.19	12.38	24.77	49.53	74.30	92.87
S505 12K - 1007	0.85	8.49	16.98	33.96	67.91	101.87	127.33
S505 15K * 0803	0.99	9.92	19.84	39.68	79.37	119.05	148.81
S505 16K * 0803	1.10	11.01	22.02	44.04	88.08	132.12	165.15
S505 18K * 0804	1.32	13.24	26.47	52.94	105.88	158.82	198.53
S505 20K * 0804	1.55	15.54	31.08	62.16	124.32	186.48	233.10
S505 22K * 0804	1.79	17.88	35.76	71.52	143.04	214.57	268.21
S505 24K * 0804	2.03	20.26	40.52	81.04	162.07	245.11	303.88
S505 25B * 0804	2.15	21.46	42.93	85.86	172.72	257.57	321.97
S505 26B * 0804	2.27	22.68	45.36	90.71	181.43	272.14	339.11
S505 28B * 0804	2.51	25.13	50.26	100.52	201.03	301.55	371.39
S505 30B * 0805	2.76	27.59	55.18	110.37	220.74	331.11	403.12
S505 32B * 0505	1.88	18.81	37.61	75.22	150.44	225.49	271.63
S505 35B * 0505	2.12	21.17	42.34	84.68	169.36	250.30	300.66
S505 36B * 0505	2.20	21.96	43.93	87.85	175.71	258.48	310.20
S505 40BF - 0504	2.51	25.13	50.26	100.53	201.05	290.27	347.13
S505 40B * 0505	2.52	25.16	50.32	100.65	201.29	290.74	347.65
S505 42B * 0505	2.68	26.77	53.55	107.09	214.19	306.59	365.96
S505 44B * 0505	2.84	28.37	56.75	113.49	226.99	322.02	383.71
S505 45B * 0505	2.92	29.18	58.37	116.74	233.47	329.75	392.59
S505 48B * 0505	3.16	31.63	63.25	126.50	252.80	356.63	418.79
S505 50B * 0505	3.33	33.26	66.52	133.04	264.20	367.63	435.89
S505 52B * 0505	3.49	34.90	69.80	139.60	275.51	382.44	452.72
S505 54B * 0505	3.65	36.54	73.08	146.17	286.71	397.03	469.26
S505 55B * 0505	3.74	37.37	74.73	149.46	292.27	404.26	477.43
S505 56B * 0505	3.82	38.19	76.38	152.76	297.80	411.43	485.53
S505 60B * 0506	4.15	41.50	83.00	165.99	319.68	439.63	517.25
S505 64B * 0506	4.48	44.82	89.64	179.28	341.14	467.04	547.92
S505 70B * 0506	4.98	49.82	99.65	199.30	372.55	506.74	602.05
S505 72B * 0506	5.15	51.50	102.99	205.99	382.81	519.61	606.27
S505 75B * 0506	5.40	54.01	108.02	216.04	398.01	538.57	627.16
S505 80BF - 0506	5.78	57.80	115.61	231.21	419.70	565.46	662.85
S505 80B * 0508	5.82	58.21	116.42	232.85	422.85	569.31	668.04
S505 90B * 0508	6.66	66.56	133.13	266.25	470.10	636.91	752.57
S505 96B * 0508	7.16	71.63	143.26	286.38	497.50	660.77	802.70
S505 100B * 0508	7.50	75.01	150.02	297.93	515.45	688.64	835.69
S505 110B * 0508	8.35	83.48	166.96	326.48	558.60	757.32	916.71
S505 120B * 0508	9.20	91.98	183.95	354.27	599.68	824.59	995.68

## ⑤ Each product dimension

## ⑥ Allowable transfer capability table

Bending strength, etc

## ④ Good information







Accuracy, Material, Pressure Angle, Heat treatment, Tooth surface hardness, Backlash, Note, etc.





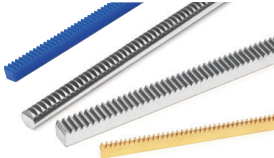

# Contents



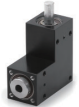

\* These are samples.





Catalogue number (Material)



Page number

		Catalogue number (Material)	Page number	
<b>Gearbox</b>		<b>Gearbox series</b> HY-BOX, BS-BOX, BSB-BOX, BSH-BOX B-SET, WS-BOX	Page 29 to 50	CONTENTS INFORMATION
<b>Anti-backlash spur gear</b>		<b>Anti-backlash ground spur gear</b> ASG series (SCM435, 440), NSG series (SCM435, 440) <b>Anti-backlash spur gear</b> NS series (S45C, AL), NSU series (SUS304)	Page 51 to 60	GEARBOXES
<b>Spur gear</b>		Ground spur gear SG series (SCM435, 440), SGR series (S45C) Spur gear S series (S45C, SUS304, Brass, Blue POM, White POM White POM with brass bushing)	Page 61 to 180	ANTI-BACKLASH SPUR GEARS
<b>Rack gear</b>		Module size rack gear RK series (S45C, SUS304, Brass, Blue POM), ORK series (SUS304) Circular pitch size rack & pinion gear RKP series (Brass, S45C), SP series (S45C)	Page 181 to 190	SPUR GEARS
<b>Helical / Screw gear</b>		<b>Helix angle 45°</b> H series (S45C, SUS304, Blue POM, White POM)	Page 191 to 204	RACKS
<b>Miter gear</b>		<b>MG series</b> (SCM440), <b>MGE series</b> (SCM435, 440) <b>M series</b> (S45C, SUS304, SUS304L, Brass, Blue POM, White POM, White POM with Brass bushing) <b>MGH series</b> (S45C), <b>ML series</b> (SUS304), <b>ML-N series</b> (S45C)	Page 205 to 238	HELICAL GEARS AND SCREW GEARS
<b>Bevel gear</b>		<b>BG series</b> (SCM440) <b>B series</b> (S45C, SUS304, Brass)	Page 239 to 256	MITER GEARS
<b>Worm &amp; Worm Wheel</b>		<b>W series</b> (SUS304, S45C) <b>G series</b> (Brass, Blue POM, White POM, White POM with Brass bushing, C6191BE, CAC702)	Page 257 to 278	BEVEL GEARS
<b>References</b>	<ul style="list-style-type: none"> <li>• Fundamental dimensions for various sizes of Tooth profile</li> <li>• Advise on gear assembly</li> <li>• Centre distance and Parallelism of axis for spur and helical gears,</li> <li>• Measurement of the backlash: Bevel gear, Worm gear</li> <li>• Tooth bearings, Gear efficiency</li> <li>• Lubricating oil, noise and oscillation for gears</li> <li>• Interpretation of Allowable capability torque table and example of use.</li> <li>• The Conversion formula of Power</li> <li>• The vocabulary of gear and gear terms, JIS standard and accuracy grade of standard products</li> <li>• Hardness conversion table</li> <li>• Commonly used fitting tolerances for bore and axis dimensions</li> <li>• Metric coarse and fine screw threads, and reference pilot hole dimensions</li> <li>• Spot facing and Thread hole for Hexagon socket head cap screws</li> <li>• Shape and dimensions of keyway for parallel key</li> <li>• C-type and E-type retaining ring (reference)</li> <li>• Explanation of material notation</li> </ul>			WORMS AND WORM WHEELS REFERENCES





Gearbox						
Catalogue number	HY-BOX	BS-BOX	BSB-BOX	BSH-BOX	B-SET	WS-BOX
Shape						
Page	P. 38	P. 40	P. 42	P. 44	P. 46	P. 48
Material	Body: Aluminum Shaft: SCM435/440, S45C	Body: Aluminum Shaft: SUS303	Body: Aluminum Shaft: SUS303	Body: Aluminum or FC200 Shaft: SUS303, S45C	Body: Aluminum Shaft: SUS303	Body: Aluminum Shaft: S45C
Axis position and overall shape	Shaft twisted	L shape, T shape	L shape	L shape, T shape	L shape	Shaft twisted
Backlash	20'	15' to 25'	15'	10' to 15'	Sensory inspection	30' to 45'
Type of gear used	Hypoid gear	Straight bevel gear	Straight bevel gear	Spiral bevel gear	Straight bevel gear	Worm gear





Anti-backlash spur gear / Control-backlash spur gear					
Catalogue number	ASG	NSG	NS	NSU	NS
Shape					
Page	P. 56	P. 56	P. 58	P. 58	P. 58
Material	SCM435, 440	SCM435, 440	S45C	SUS304	A5056
Module	m1 to 2	m0.5 to 1	m0.8 to 1	m0.5	m0.5 to 1
Mechanism parts	Fixing bolts	Arc spring / Coil spring	Coil spring	Coil spring	Arc spring
Teeth process sequence	Grinding after Induction hardening	Grinding	Soft nitriding after cutting	Teflon after cutting	White alumite after cutting





Ground spur gear / Spur gear					
Catalogue number	SG	SGR	S	S	S
Shape					
Page	P. 66	P. 82	P. 94	P. 136	P. 146
Material	SCM435 · 440	S45C	S45C	SUS304	Brass
Module	m0.5 to 3	m0.5 to 3	m0.5 to 3	m0.5 to 2	m0.3 to 0.8
Accuracy grade	JIS Class N5	JIS Class N6	JIS Class N8	JIS Class N9	JIS Class N9 / Outside of control range
Teeth process sequence	Grinding after Induction hardening	Grinding after induction hardening (black oxide is removed)	Cutting	Cutting	Cutting

Spur gear				
Catalogue number	S	S	S	S
Shape				
Page	P. 158	P. 160	P. 170	P. 176
Material	White POM (w/ brass bushing)	Blue POM	White POM	White POM (w/ screw hole)
Module	m1	m0.5 to 3	m0.5 to 1	m0.5 to 1
Accuracy grade	JIS Class N9 to N10 *	JIS Class N9 to N10 *	JIS Class N9 to N10 *	JIS Class N9 to N10 *
Teeth process sequence	Cutting	Cutting	Cutting	Cutting

※ Accuracy at the time of manufacture.

Module size rack gear					
Catalogue number	RK	ORK	RK	RK	RK
Shape					
Page	P. 183	P. 184	P. 184	P. 185	P. 185
Material	S45C	SUS304	SUS304	Brass	Blue POM
Module	m1 to 3	m0.5 to 1	m0.5 to 1.5	m0.3 to 0.8	m0.5 to 1
Heat treatment	—	—	—	—	—
Teeth process sequence	Cutting	Cutting	Cutting	Cutting	Cutting

CP size rack gear				
Catalogue number	RKP	SP	RKP	SP
Shape				
Page	P. 188	P. 188	P. 189	P. 189
Material	Brass	S45C	S45C	S45C
Circular Pitch (CP)	CP2	CP2	CP5 / CP10	CP5 / CP10
Heat treatment	—	—	—	—
Teeth process sequence	Cutting	Cutting	Cutting	Cutting

Helical Gear / Screw Gear (Helix angle: 45°)				
Catalogue number	H	H	H	H
Shape				
Page	P. 194	P. 196	P. 198	P. 202
Material	S45C	SUS304	Blue POM	White POM
Module	m1 to 3	m1 to 1.5	m1 to 3	m1 to 1.5
Accuracy grade	JIS Class N9	JIS Class N9	JIS Class N9 to N10 *	JIS Class N9 to N10 *
Teeth process sequence	Induction hardening after cutting	Cutting	Cutting	Cutting

\* Accuracy at the time of manufacture.



# Index

CONTENTS

INFORMATION

GEARBOXES

ANTI-BACKLASH  
SPUR GEARS

SPUR GEARS

RACKS







HELICAL GEARS AND  
SCREW GEARS







MITER GEARS





BEVEL GEARS







WORMS AND WORM  
WHEELS

REFERENCES







Miter gear Gear ratio (1 : 1)						
Catalogue number	MG	MGE	M	M	M	MGH
Shape						
Page	P. 212	P. 214	P. 216	P. 218	P. 220	P. 222
Material	SCM440	SCM435, 440	S45C	S45C	S45C	S45C
Module	m1.5 to 3	m1.5 to 3	m0.8 to 3	m1 to 3	m1 to 3	m1 to 2
Tooth trace shape	<b>Spiral</b>	<b>Spiral</b>	<b>Spiral</b>	<b>Spiral</b>	<b>Spiral</b>	<b>Spiral</b>
Accuracy grade	JIS Class 1	JIS Class 2	JIS Class 3	JIS Class 4	JIS Class 4	JIS Class 4
Teeth process sequence	Grinding after Induction hardening	Grinding after Induction hardening	Cutting	Induction hardening & black oxide after cutting	Induction hardening after cutting	Induction hardening after cutting

Miter gear Gear ratio (1 : 1)						
Catalogue number	ML-N	ML	M	M	MGH	M
Shape						
Page	P. 224	P. 224	P. 226	P. 228	P. 230	P. 232
Material	S45C	SUS304	S45C	S45C	S45C	SUS304
Module	m1 to 2.5	m0.8 to 2	m0.5 to 4	m1.5 to 4	m2.5 to 3	m0.8 to 3
Tooth trace shape	Straight	Straight	Straight	Straight	Straight	Straight
Accuracy grade	JIS Class 3	JIS Class 4	JIS Class 3	JIS Class 4	JIS Class 4	JIS Class 4
Teeth process sequence	Cutting	Cutting	Cutting	Induction hardening after cutting	Induction hardening after cutting	Cutting





Miter gear Gear ratio (1 : 1)				
Catalogue number	M	M	M	M
Shape				
Page	P. 232	P. 234	P. 234	P. 236
Material	SUS304L	Brass	White POM	Blue POM
Module	m0.5 to 1	m0.5 to 1	m1	m0.8 to 3
Tooth trace shape	Straight	Straight	Straight	Straight
Accuracy grade	—	JIS Class 4	JIS Class 5 to 6 *	JIS Class 5 to 6 *
Teeth process sequence	MIM (metal injection molding)	Cutting	Cutting	Cutting







Bevel gear Gear ratio (1 : 1.5 / 1 : 2 / 1 : 3)						
Catalogue number	BG	B	B	B	B	B
Shape						
Page	P. 244	P. 246	P. 248	P. 250	P. 252	P. 254
Material	SCM440	S45C	S45C	S45C	S45C	SUS304
Module	m1.5 to 2.5	m1 to 3	m1 to 2.5	m0.5 to 3	m1.5 to 4	m0.8 to 2
Tooth trace shape	<b>Spiral</b>	<b>Spiral</b>	<b>Spiral</b>	Straight	Straight	Straight
Accuracy grade	JIS Class 1	JIS Class 3	JIS Class 4	JIS Class 3	JIS Class 4	JIS Class 4
Teeth process sequence	Grinding after Induction hardening	Cutting	Induction hardening after cutting	Cutting	Induction hardening after cutting	Cutting



Bevel gear Gear ratio (1 : 1.5 / 1 : 2 / 1 : 3)	
Catalogue number	B
Shape	
Page	P. 254
Material	Brass
Module	m0.5 to 0.8
Tooth trace shape	Straight
Accuracy grade	JIS Class 4
Teeth process sequence	Cutting

Worm / Worm Wheel Module 0.5 to 3						
Catalogue number	W50	W50	G50	G50	G50	W80
Shape						
Page	P. 262	P. 263	P. 262	P. 262	P. 262	P. 264
Material	SUS304	S45C	CAC702	Brass	Blue POM	SUS304
Module	m0.5	m0.5	m0.5	m0.5	m0.5	m0.8
Teeth process sequence	Precision cold rolling	Precision cold rolling	Cutting	Cutting	Cutting	Precision cold rolling

Worm / Worm Wheel Module 0.5 to 3						
Catalogue number	W80	G80	G80	G80	W1	W1
Shape						
Page	P. 265	P. 264	P. 264	P. 264	P. 266	P. 267
Material	S45C	CAC702	Blue POM	White POM	SUS304	S45C
Module	m0.8	m0.8	m0.8	m0.8	m1	m1
Teeth process sequence	Precision cold rolling	Cutting	Cutting	Cutting	Precision cold rolling	Precision cold rolling

Worm / Worm Wheel Module 0.5 to 3						
Catalogue number	G1	G1	G1	W1.5	W1.5	G1.5
Shape						
Page	P. 266	P. 266	P. 268	P. 270	P. 271	P. 270
Material	White POM / White POM (w/ brass bushing)	Blue POM	CAC702	SUS304	S45C	White POM / White POM (w/ brass bushing)
Module	m1	m1	m1	m1.5	m1.5	m1.5
Teeth process sequence	Cutting	Cutting	Cutting	Precision cold rolling	Precision cold rolling	Cutting

Worm / Worm Wheel Module 0.5 to 3						
Catalogue number	G1.5	G1.5	W2	G2	W2.5	G2.5
Shape						
Page	P. 270	P. 272	P. 274	P. 274	P. 276	P. 276
Material	Blue POM	CAC702	S45C	CAC702	S45C	CAC702
Module	m1.5	m1.5	m2	m2	m2.5	m2.5
Teeth process sequence	Cutting	Cutting	Precision cold rolling	Cutting	Cutting	Cutting

Worm / Worm Wheel Module 0.5 to 3		
Catalogue number	W3	G3
Shape		
Page	P. 277	P. 277
Material	S45C	CAC702
Module	m3	m3
Teeth process sequence	Cutting	Cutting

# Alphabetical search

※ Refer to the References for the details of the accuracy grade.

	Catalogue number	Gear type	Page	Material	Accuracy grade	Teeth process sequence	
<b>A</b>	ASG1S to ASG2S	Control-backlash spur gear	P. 56	SCM435・440	JIS N5	Grinding after Induction hardening	
	B50B to B80B	Bevel gear (straight)	P. 254	Brass	JIS 4	Cutting	
	B50S to B3S	Bevel gear (straight)	P. 250	S45C	JIS 3	Cutting	
	B1.5S-H to B4S-H	Bevel gear (straight)	P. 252	S45C	JIS 4	Induction hardening after cutting	
	B1S-L to B3S-L	Bevel gear (spiral)	P. 246	S45C	JIS 3	Cutting	
	B1S-R to B3S-R	Bevel gear (spiral)	P. 246	S45C	JIS 3	Cutting	
	B1S-L-H to B2.5S-L-H	Bevel gear (spiral)	P. 248	S45C	JIS 4	Induction hardening after cutting	
	B1S-R-H to B2.5S-R-H	Bevel gear (spiral)	P. 248	S45C	JIS 4	Induction hardening after cutting	
	B80SU to B2SU	Bevel gear (straight)	P. 254	SUS304	JIS 4	Cutting	
	<b>B</b>	BE40L to BE88L	Bevel gearbox (L shape)	P. 46	Body: Aluminum, Cover: Plastic	—	—
		BG1.5S-L-H to BG2.5S-L-H	Bevel gear (spiral)	P. 244	SCM440	JIS 1	Grinding after Induction hardening
		BG1.5S-R-H to BG2.5S-R-H	Bevel gear (spiral)	P. 244	SCM440	JIS 1	Grinding after Induction hardening
		BS35L to BS105L	Bevel gearbox (L shape)	P. 40	Body: Aluminum	—	—
		BS45T to BS105T	Bevel gearbox (T shape)	P. 40	Body: Aluminum	—	—
		BSB65L to BSB105L	Bevel gearbox hollow shaft type (L shape)	P. 42	Body: Aluminum	—	—
BSH70L to BSH170L		Bevel gearbox strength enhancement type (L shape)	P. 44	Body: Aluminum or FC200	—	—	
BSH70T to BSH145T		Bevel gearbox strength enhancement type (T shape)	P. 44	Body: Aluminum or FC200	—	—	
<b>G</b>		G50A-R to G3A-R	Worm wheel	P. 262	CAC702, C6191BE	—	Cutting
		G1A-L to G3A-L	Worm wheel	P. 268	CAC702, C6191BE	—	Cutting
	G50B	Worm wheel	P. 262	Brass	—	Cutting	
	G50BP to G1.5BP	Worm wheel	P. 262	Blue POM	—	Cutting	
	G80D to G1.5D	Worm wheel	P. 264	White POM	—	Cutting	
	G1DB to G1.5DB	Worm wheel	P. 266	White POM (w/ brass bushing)	—	Cutting	
	<b>H</b>	H1BP-L to H3BP-L	Helical gear	P. 198	Blue POM	JIS N9 to 10	Cutting
H1BP-R to H3BP-R		Helical gear	P. 198	Blue POM	JIS N9 to 10	Cutting	
H1D-L to H1.5D-L		Helical gear	P. 202	White POM	JIS N9 to 10	Cutting	
H1D-R to H1.5D-R		Helical gear	P. 202	White POM	JIS N9 to 10	Cutting	
H1S-L to H3S-L		Helical gear	P. 194	S45C	JIS N9	Induction hardening after cutting	
H1S-R to H3S-R		Helical gear	P. 194	S45C	JIS N9	Induction hardening after cutting	
H1SU-L		Helical gear	P. 196	SUS304	JIS N9	Cutting	
H1SU-R to H1.5SU-R		Helical gear	P. 196	SUS304	JIS N9	Cutting	
HY70R to HY150R		Hypoid gearbox (shaft twisted)	P. 38	Body: Aluminum	—	—	
<b>M</b>	M50B to M1B	Miter gear (straight)	P. 234	Brass	JIS 4	Cutting	
	M80BP to M3BP	Miter gear (straight)	P. 236	Blue POM	—	Cutting	
	M1D	Miter gear (straight)	P. 234	White POM	—	Cutting	
	M50S to M4S	Miter gear (straight)	P. 226	S45C	JIS 3	Cutting	
	M1.5S-H to M4S-H	Miter gear (straight)	P. 228	S45C	JIS 4	Induction hardening after cutting	
	M80S-L to M3S-L	Miter gear (spiral)	P. 216	S45C	JIS 3	Cutting	
	M80S-R to M3S-R	Miter gear (spiral)	P. 216	S45C	JIS 3	Cutting	
	M1S-L-H to M3S-L-H	Miter gear (spiral)	P. 220	S45C	JIS 4	Induction hardening after cutting	
	M1S-R-H to M3S-R-H	Miter gear (spiral)	P. 220	S45C	JIS 4	Induction hardening after cutting	
	M1S-R-HB to M3S-R-HB	Miter gear (spiral)	P. 218	S45C	JIS 4	Induction hardening & black oxide after cutting	

# Alphabetical search

	Catalogue number	Gear type	Page	Material	Accuracy grade	Teeth process sequence
<b>M</b>	M1S-L-HB to M3S-L-HB	Miter gear (spiral)	P. 218	S45C	JIS 4	Induction hardening & black oxide after cutting
	M80SU to M3SU	Miter gear (straight)	P. 232	SUS304	JIS 4	Cutting
	M50SUM to M1SUM	Miter gear (straight)	P. 232	SUS304L	—	MIM (metal injection molding)
	MGE1.5S-L-H to MGE3S-L-H	Miter gear (spiral)	P. 214	SCM435 · 440	JIS 2	Grinding after Induction hardening
	MGE1.5S-R-H to MGE3S-R-H	Miter gear (spiral)	P. 214	SCM435 · 440	JIS 2	Grinding after Induction hardening
	ML1S-N to ML2.5S-N	Miter gear (straight)	P. 224	S45C	JIS 3	Cutting (w/ boss fastening mechanism)
	ML80SU to ML2SU	Miter gear (straight)	P. 224	SUS304	JIS 4	Cutting (w/ boss fastening mechanism)
	MG1.5S-L-H to MG3S-L-H	Miter gear (spiral)	P. 212	SCM440	JIS 1	Grinding after Induction hardening
	MG1.5S-R-H to MG3S-R-H	Miter gear (spiral)	P. 212	SCM440	JIS 1	Grinding after Induction hardening
	MGH	Miter gear (straight)	P. 230	S45C	JIS 4	Induction hardening after cutting
	MGH-L	Miter gear (spiral)	P. 222	S45C	JIS 4	Induction hardening after cutting
	MGH-R	Miter gear (spiral)	P. 222	S45C	JIS 4	Induction hardening after cutting
<b>N</b>	NS50AL to NS1AL	Anti-backlash spur gear	P. 58	Aluminum	JIS N9	Cutting
	NS80S to NS1S	Anti-backlash spur gear	P. 58	S45C	JIS N8	Cutting
	NS50SU	Anti-backlash spur gear	P. 58	SUS304	JIS N9	Cutting
	NSG50S to NSG1S	Anti-backlash spur gear	P. 56	SCM435·440	JIS N5	Grinding
<b>O</b>	ORK50SU to ORK1SU	Round rack gear	P. 184	SUS304	—	Cutting
<b>R</b>	RK30B to RK80B	Rack gear	P. 185	Brass	—	Cutting
	RK50BP to RK1BP	Rack gear	P. 185	Blue POM	—	Cutting
	RK1SD to RK3SD	Rack gear	P. 183	S45C	—	Cutting
	RK50SU to RK1.5SU	Rack gear	P. 184	SUS304	—	Cutting
	RKP2B	Rack gear	P. 188	Brass	—	Cutting
	RKP5SD to RKP10SD	Rack gear	P. 189	S45C	—	Cutting
<b>S</b>	S30B to S80B	Spur gear	P. 146	Brass	JIS N9	Cutting
	S50BP to S3BP	Spur gear	P. 160	Blue POM	JIS N9 to 10	Cutting
	S50D to S1D	Spur gear	P. 170	White POM	JIS N9 to 10	Cutting
	S1DB	Spur gear	P. 158	White POM (w/ brass bushing)	JIS N9 to 10	Cutting
	S50S to S3S	Spur gear	P. 94	S45C	JIS N8	Cutting
	S50SU to S2SU	Spur gear	P. 136	SUS304	JIS N9	Cutting
	SG50S to SG3S	Ground spur gear	P. 66	SCM435 · 440	JIS N5	Grinding after Induction hardening
	SGR50S to SGR3S	Ground spur gear	P. 82	S45C	JIS N6	Grinding after Induction hardening
	SP2S to SP10S	CP Pinion (for CP Rack gear)	P. 188	S45C	JIS N8	CP size, Cutting
<b>W</b>	W50SU-R to W1.5SU-R	Worm	P. 262	SUS304	—	Precision cold rolling
	W1S-L to W3S-L	Worm	P. 267	S45C	—	Precision cold rolling or Cutting
	W50S-R to W3S-R	Worm	P. 263	S45C	—	Precision cold rolling or Cutting
	WS55R to WS90R	Worm gearbox (shaft twisted)	P. 48	Body: Aluminum	—	—

Search method:

Miter gear	M1S30R*2610H	➡	M (module) S-R-H
Rack gear	RK1SD10-1015	➡	RK (module) SD
Spur gear	S1S100B-1012	➡	S (module) S
Worm	W1S R1+B	➡	W (module) S-R

# Select gears based on usage

CONTENTS

INFORMATION

GEARBOXES

ANTI-BACKLASH SPUR GEARS

SPUR GEARS

RACKS

HELICAL GEARS AND SCREW GEARS

MITER GEARS

BEVEL GEARS

WORMS AND WORM WHEELS

REFERENCES

## Transfer of rotational motion between parallel shafts: Spur gears, helical gears, anti-backlash spur gears

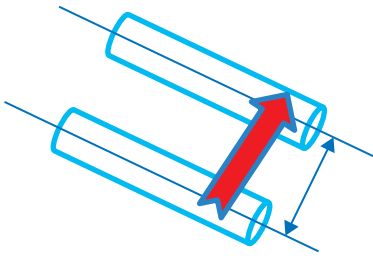

### Cautions on assembly:

- ① Center distance: For KG's spur gears, helical gears, and anti-backlash gears, we recommend setting the center distance to a value larger than the theoretical value.
- ② Arrange the bearing as close to the gear as possible and fasten it from both sides.
- ③ Helical gears are subject to a thrust load, and therefore, use thrust bearings or similar parts.



Example of use	Gear series used
High torque, high accuracy, low noise	SG, ASG (backlash control function)
High torque, low noise, high cost-performance	SGR
High torque, high cost-performance	Induction-hardened products
Elimination of backlash	NSG, NS, NSU
For medical use and for food and drinking water	Spur gears and helical gears made of SUS304 or blue or white POM
Humid environments	Spur gears and helical gears made of SUS304 or blue or white POM

## Transfer of rotational motion between intersecting shafts with a shaft angle of 90° : Miter gears and bevel gears

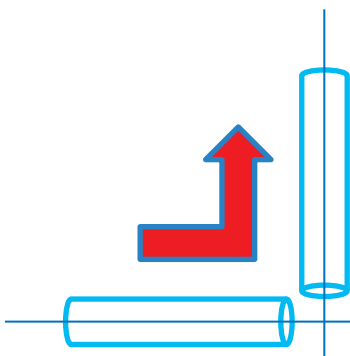

### Cautions on assembly:

- ① Assembly distance: Adjust the assembly distance to the value set by KG.
  - ② Tooth contact check: Check that a pair of bevel gears have proper tooth contact.
  - ③ Bevel gears are subject to a thrust load, and therefore, use thrust bearings or similar parts.
- ★ Shaft check: The shafts may deform if they do not have adequate strength or are subject to an excessive load. Check the perpendicularity as well.



Example of use	Gear series used
High torque, high accuracy, low noise	MG, BG
High torque, low noise, high cost-performance	MGE
High torque, high cost-performance	MGH, induction-hardened miter and bevel gears
Pursuit of convenience in assembly	BS, BSB, BSH, B-SET, ML, ML-N
For medical use and for food and drinking water	Miter gears and bevel gears made of SUS304 or blue or white POM
Humid environments	Miter gears and bevel gears made of SUS304 or blue or white POM

# Select gears based on usage

## Transfer of rotational motion between helical gears with the shaft twisted 90° : Worm gears and helical gears

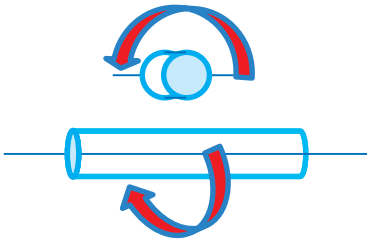

### Cautions on assembling worm gears:

- ① Assembly distance: For KG' s worms and worm wheels, we recommend setting the center distance to a value larger than the theoretical value.
- ② Arrange the bearing as close to the gear as possible and fasten it from both sides.
- ③ A thrust load is generated. Use thrust bearings or similar parts.
- ④ Warm-up operation: Warm-up operation provides an increased tooth contact area, enabling the product to be used in the allowable torque range.
- ⑤ Lubrication: For low-speed operation, apply grease lubrication, and for high-speed operation, use oil bath lubrication. Add oil up to the center of the worm when the worm is used below the worm wheel, and 1/3 of the worm wheel diameter when the worm is used above the worm wheel.

### Cautions on assembling screw gears:

With this assembly method, the gears have a point contact and wear quickly. Screw gears can be assembled more easily than bevel gears.

- ① Assembly distance: For KG' s helical gears, we recommend setting the center distance to a value larger than the theoretical value.
- ② Arrange the bearing as close to the gear as possible and fasten it from both sides.
- ③ A thrust load is generated. Use thrust bearings or similar parts.

Example of use	Gear series used
For medical use and for food and drinking water	SUS304 worms, blue and white POM worm wheels, blue and white POM helical gears
High accuracy and pursuit of convenience in mounting and assembly	WS, HY
Humid environments	SUS304 worms, blue and white POM worm wheels, blue and white POM helical gears

## Conversion of rotational motion to linear motion: Racks and CP racks

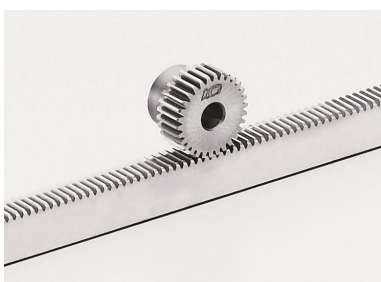
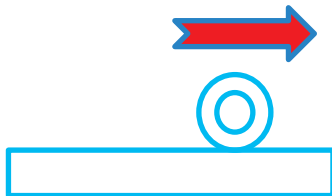

### Cautions on use:

- ① The pinion wears more quickly than the rack, and therefore, a more durable material may be selected for the pinion.
- ② Stick to the rack contact height set by KG.
- ③ Gears with a module size are not compatible with those with a CP size.

Example of use	Gear series used
General use	RK, S
When the center travel distance per revolution is set to an integer	RKP, SP
For medical use and for food and drinking water	SUS304 and blue and white POM racks and pinions
Elimination or control of backlash	Use a NSG, NS, NSU, or ASG gear having the same module as the rack.

# About additional machining

We offer additional machining services for standard gears, even a single gear.



We offer products with various numbers of teeth, face widths, and hole diameters to meet a wide range of needs. We also offer additional machining (secondary processing) services for standard gears to more completely meet customer needs.

## Notes on additional machining of gear holes

Each KG gear series is available with several different hole diameters. To maintain the accuracy and performance of KG gears, avoid additional hole machining. If additional hole machining is required, use an F type gear (marked with “-” )

For centering, use a soft scroll chuck, three-claw scroll chuck, or similar tool. In additional machining, the maximum working diameter must be 60 to 70% of the hub diameter.

### Cautions on chucking

When holding a gear with a chuck during additional machining, do not set the chuck in the stamped area.

### Cautions on additional machining of hardened products

When additional machining is required for an induction-hardened gear, note that the area around the teeth has hardened due to the effect of heat treatment. Also, note that gears with a small outside diameter (with a small number of teeth) have low machinability because the hole surface has hardened due to the effect of hardening.

## Cautions on Additional Machining of Ground Spur Gears

Avoid additional hole machining for ground spur gears. Additional machining may deteriorate the accuracy of gears. In general, additional key groove machining slightly increases the pitch error. The closer the root circle is to the key groove, the more the pitch error increases. After additional machining, the gear accuracy decreases (by one or two classes).

### Example of additional hole machining of ground spur gears

Be sure to hold the product with a soft jaw and scroll chuck and perform centering from the hole surface.

The circumference and lateral face have been ground, and therefore, centering is easy if the product is held as shown in the figure.

Note that gears with a small outside diameter (with a small number of teeth) have low machinability because the hole surface has hardened due to the effect of hardening.

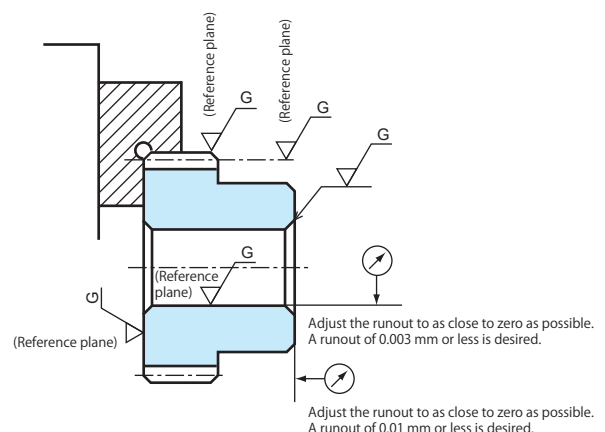

# Notes on additional machining

## Example of additional hole machining of gears

### Spur gears (SG and SGR Series) and helical gears

When holding the tooth tip circumference, be careful not to deform the teeth.

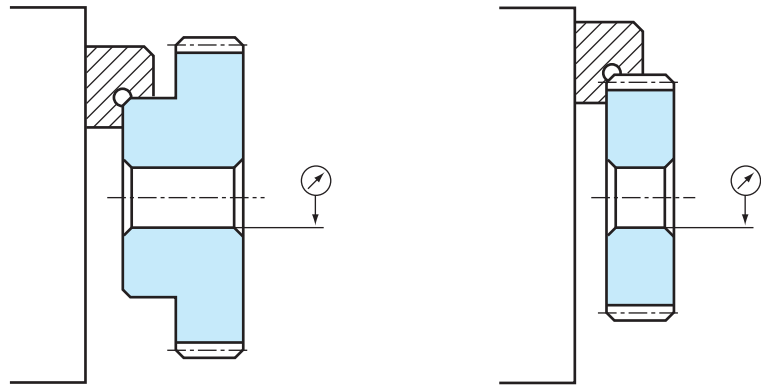

### Worms and worm wheels

For cold-rolled worms, we recommend holding the product as deeply as possible in the chuck, especially when holding the tooth tip circumference. When doing so, be careful not to deform the teeth.

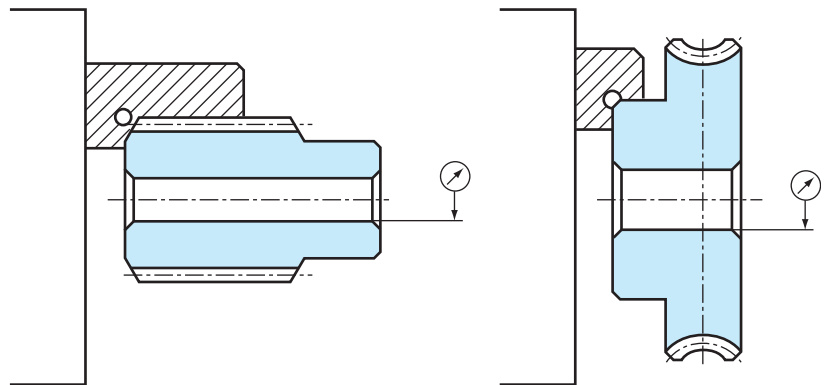

### Miter gears and bevel gears

For gears with a module of  $m2.0$  or more, the tooth tip circumference has been chamfered parallel to the shaft center, which enables easy chucking. When holding the tooth tip circumference with a chuck, be careful not to deform the teeth.

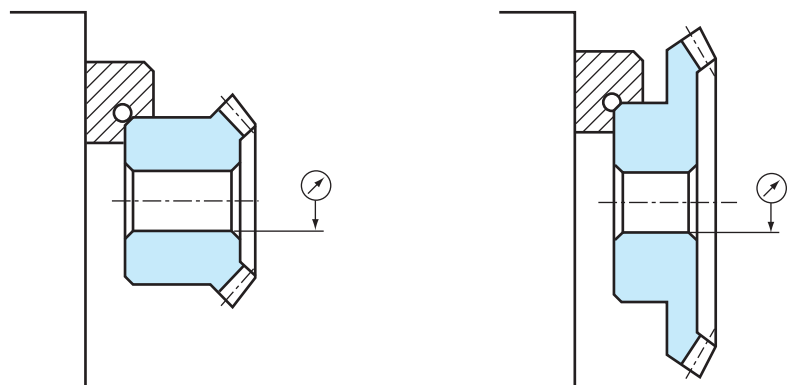



# About custom-made gears

## We offer custom-made gears, even a single one, to meet your needs.

Taking advantage of the knowhow we have accumulated for producing precision, small standard gears, we offer custom-made gears in addition to standard products.



We offer KG-STOCK GEARS with various numbers of teeth, face widths, hole diameters, and hub diameters to meet a wide range of needs. When designing your device, first see if there is a KG-STOCK GEAR available. If you cannot find an appropriate gear among our KG-STOCK GEARS, please send your design drawings.

Please consult with us about price and delivery.

If you have any questions about design, please feel free to contact us. Our engineering department and branch offices have experienced engineering service personnel to meet your requests.

Note) Please note that, depending on our production capacity and equipment capabilities, we may not be able to accept your request or order.

## Reference drawing (example)

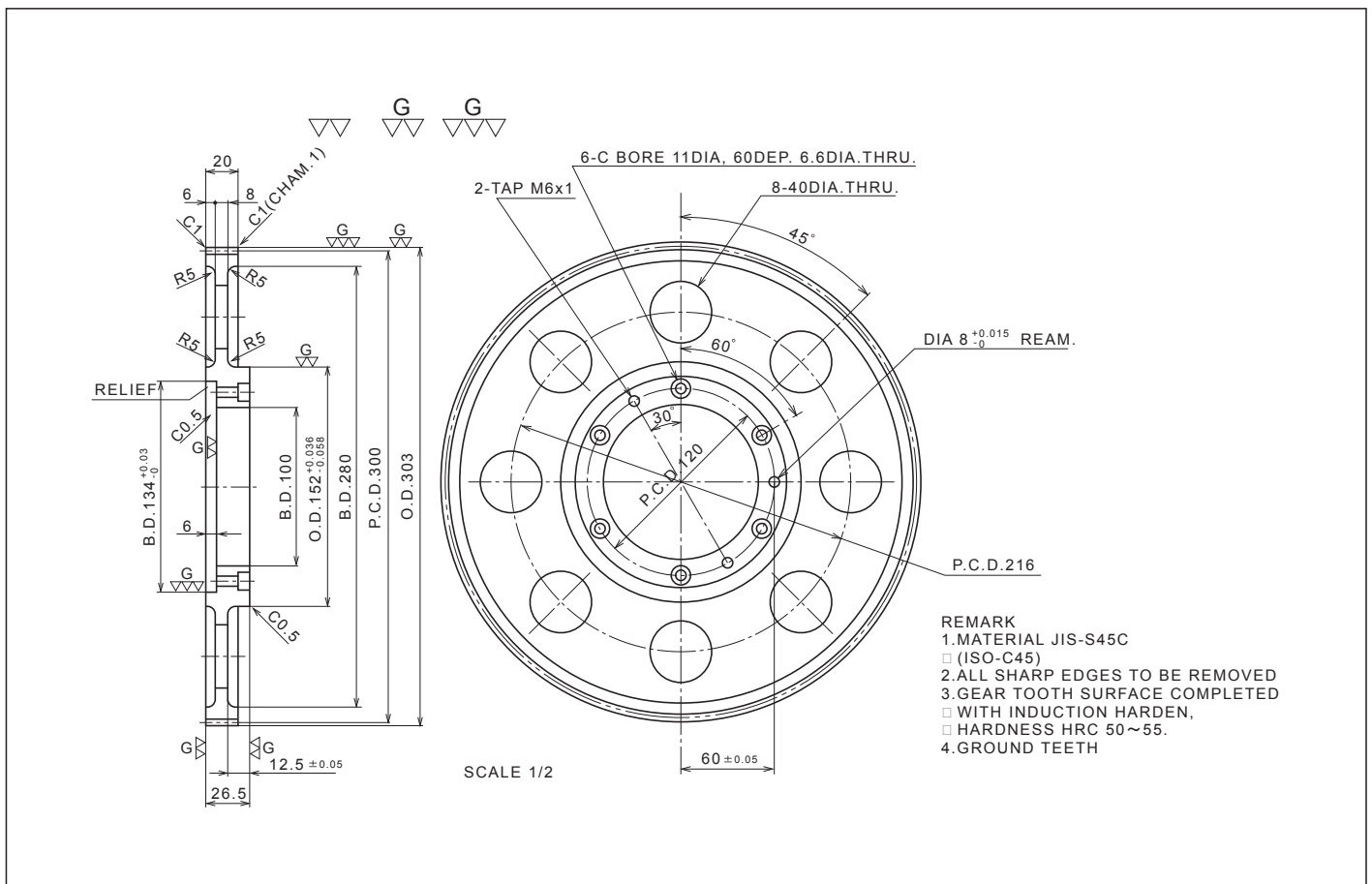

# About custom-made gears

We offer small-module and small gears, including spur gears and bevel gears. We also offer inspection services for our products.

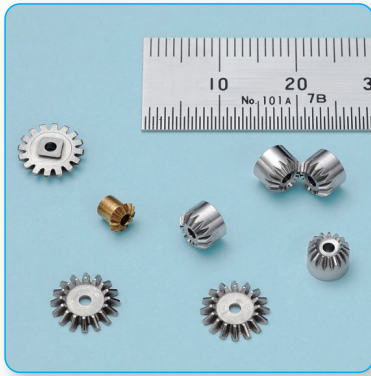

We offer spur gears and bevel gears with a module of 0.3.



We have introduced the latest gear grinding machine Reishauer RZ260 4.0 (made in Switzerland) to offer custom-made products.

Tooth surface polishing provides high-accuracy, high-efficiency, high-strength, low-noise gears.

## Specification checklist for custom-made gears

	Size	Material	Number of teeth	Shape	Outside diameter	Helix angle and direction	Number of threads	Number of teeth of mating gear	Assembly distance	Heat treatment	Surface treatment
Spur gear	<input type="radio"/>	<input type="radio"/>	<input type="radio"/>	<input type="radio"/>						<input type="radio"/>	<input type="radio"/>
Rack	<input type="radio"/>	<input type="radio"/>		<input type="radio"/>						<input type="radio"/>	<input type="radio"/>
Helical gear	<input type="radio"/>	<input type="radio"/>	<input type="radio"/>	<input type="radio"/>		<input type="radio"/>		<input type="radio"/>		<input type="radio"/>	<input type="radio"/>
Worm gear	<input type="radio"/>	<input type="radio"/>	<input type="radio"/>	<input type="radio"/>	<input type="radio"/>	<input type="radio"/>	<input type="radio"/>	<input type="radio"/>	<input type="radio"/>	<input type="radio"/>	<input type="radio"/>
Bevel gear	<input type="radio"/>	<input type="radio"/>	<input type="radio"/>	<input type="radio"/>		<input type="radio"/>		<input type="radio"/>	<input type="radio"/>	<input type="radio"/>	<input type="radio"/>

Please make requests and orders based on your drawings and specifications.  
Depending on our equipment capabilities, we may not be able to accept your request or order.

## Customization of ground gears

Gear types: Spur gears, Helical gears, Spiral miter gears, Spiral bevel gears  
Module size  $m$  (min. 0.3 to max. 3.0): Please consult with us.

DP (inch) size: Please consult with us.

Number of teeth: 10 to 500 / Outside diameter:  $\varnothing$  8 to 350 mm / Face width: max. 200 mm / Maximum helix angle (right and left) 45°

Guaranteed accuracy grade: Please consult with us.

## Production flow for custom-made gears

1. Customer provides a drawing.
2. Our engineering and sales departments look over the customer's drawing, specifications, and conditions and determine the feasibility.
3. A meeting is held with the customer to discuss the details of the drawing. (e.g., dimensions, tolerances)
4. The details of the drawing and production quantity are determined.
5. We submit an official estimate. (Price and delivery)
6. The customer approves the estimate specifications and submits the order form.
7. Final check of the drawing. The customer signs the specification drawing.  
\* To be prepared based on our specification drawing.
8. Production starts.

# List of KG gear dimension symbols

KG gear type and simple drawing	Part names	Symbol
<p><b>Spur gear, Helical gear</b></p> <p>K1 type      L1 type</p> <p>K2 type      L2 type</p> <p>A1 type      B1 type      B2 type      B3 type</p>	<p>Tip diameter</p> <p>Reference diameter</p> <p>Hub diameter</p> <p>Hole diameter</p> <p>Overall length</p> <p>Face width</p> <p>Hub length</p> <p>Dimension of Rim</p> <p>Thickness of Web</p>	<p><math>d_a</math></p> <p><math>d</math></p> <p><math>d_h</math></p> <p><math>d_d</math></p> <p><math>l</math></p> <p><math>b</math></p> <p><math>l_h</math></p> <p><math>d_i</math></p> <p><math>b_w</math></p>
<p><b>Rack gear</b></p> <p><math>h</math>      <math>h''</math>      <math>b</math>      <math>l</math></p> <p><math>h''</math>      <math>l</math>      <math>b_e</math>      <math>l_h</math>      <math>d_h</math></p>	<p>Overall length</p> <p>Datum line</p> <p>Face width</p> <p>Height</p> <p>Shaft diameter</p> <p>Effective contact length</p> <p>Stem length</p>	<p><math>l</math></p> <p><math>h''</math></p> <p><math>b</math></p> <p><math>h</math></p> <p><math>d_h</math></p> <p><math>b_e</math></p> <p><math>l_h</math></p>
<p><b>Rack &amp; Pinion</b></p> <p><math>a</math>      <math>h''</math></p>	<p>Assembly distance</p> <p>Rack datum line</p>	<p><math>a</math></p> <p><math>h''</math></p>

# List of KG gear dimension symbols

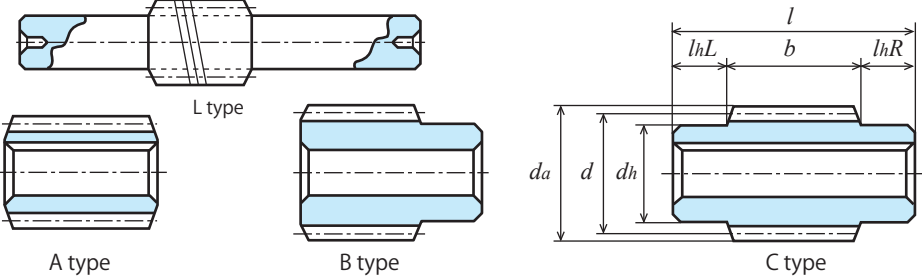
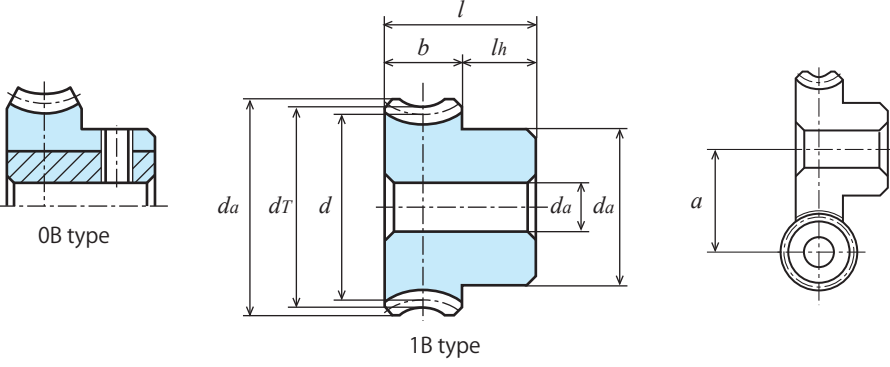
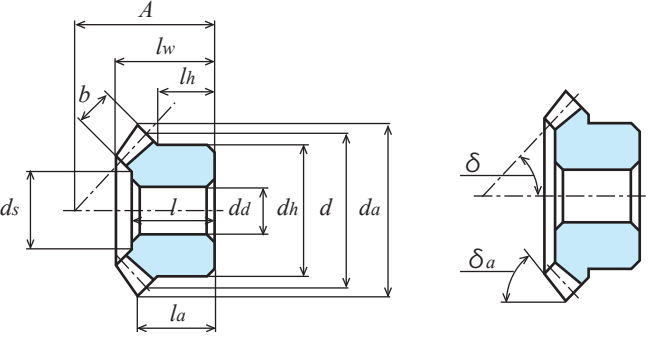
KG gear type and simple drawing	Part names	Symbol
<p><b>Worm</b></p> 	<p>Tip diameter</p> <p>Reference diameter</p> <p>Hub diameter</p> <p>Hole diameter</p> <p>Overall length</p> <p>Face width</p> <p>Hub length</p>	<p><math>d_a</math></p> <p><math>d</math></p> <p><math>d_h</math></p> <p><math>d_d</math></p> <p><math>l</math></p> <p><math>b</math></p> <p><math>l_h</math></p>
<p><b>Worm wheel</b></p> 	<p>Tip diameter</p> <p>Throat diameter</p> <p>Intermeshing pitch circle diameter</p> <p>Hub diameter</p> <p>Hole diameter</p> <p>Overall length</p> <p>Face width</p> <p>Hub length</p> <p>Intermeshing center distance</p>	<p><math>d_a</math></p> <p><math>d_r</math></p> <p><math>d</math></p> <p><math>d_h</math></p> <p><math>d_d</math></p> <p><math>l</math></p> <p><math>b</math></p> <p><math>l_h</math></p> <p><math>a</math></p>
<p><b>Miter gear, Bevel gear</b></p> 	<p>Assembly distance</p> <p>Tip diameter</p> <p>Reference diameter</p> <p>Hub diameter</p> <p>Hole diameter</p> <p>Tip angle</p> <p>Pitch angle</p> <p>Face width</p> <p>Hub length</p> <p>Overall length</p> <p>Distance from end face to tip</p> <p>Hole length</p> <p>Counter bore diameter</p>	<p><math>A</math></p> <p><math>d_a</math></p> <p><math>d</math></p> <p><math>d_h</math></p> <p><math>d_d</math></p> <p><math>\delta_a</math></p> <p><math>\delta</math></p> <p><math>b</math></p> <p><math>l_h</math></p> <p><math>l_w</math></p> <p><math>l_a</math></p> <p><math>l</math></p> <p><math>d_s</math></p>

Please be aware that KG product is subject to dimensional changes without prior notice, to the extent that it does not adversely affect the functionality.

# Our environmental efforts and action on EU RoHS2 Directive

Recognizing global environmental preservation as one of the highest priority issues for all mankind, KYOIKU GEAR MFG. CO., LTD. is continuously working to reduce environmental burdens and contribute to realizing an economic society that can grow sustainably.

**RoHS2 Directive** : Requires non-use of 10 substances: lead, mercury, cadmium, hexavalent chromium, two specified brominated flame retardants (PBB and PBDE), and phthalates (DEHP, BBP, DBP, and DIBP).

**EU RoHS Directive** : This is a directive of the European Union (EU) that restricts the use of specified hazardous substances in electronic and electrical devices. Currently, the use of the above 10 substances is restricted.

## Action on our standard products :

We are gradually switching over to products that comply with the RoHS2 Directive.  
In November 2006, we began producing brass (C3604B and C3771) products that adopt low-cadmium material, thereby offering RoHS compliant products.  
From November 21, 2023, we will begin producing S45C carbon steel products with a lead content of 0.1wt% or less, and have begun switching to products that comply with the RoHS2 Directive.  
For details, feel free to check out our official website.  
<https://www.kggear.co.jp/en/rohs2>

## How to obtain RoHS2 Directive compliant products? :

Please consult with us beforehand. However, please note that products for which the changeover has not been completed may be made to order.

**Chinese RoHS Directive** : Not compliant.

# About our products

We have made every effort to ensure that everything is correct, but if there is any problem, please contact us. All contents posted are subject to change without prior notice and will be posted on our website at any time. The copyright of all content published in this catalog belongs to our company, so it is prohibited to copy, reprint, etc. any part or all of the content without our permission.

## About hole diameter inspection

The hole diameter inspection of our products is based on our internal inspection standards and is measured using a gauge (Plug gauge, Pin gauge, etc...).

## About lot numbers

On our products, the lot number is printed on the label along with the catalogue number. By recording and keeping this lot number at your company, we will be traceable (can do tracking survey) of the product, and we will be able to respond quickly to various inquiries about the delivered product. As it's very important information, please keep the label in a safe place or take down the numbers on it.

### Lot number



Item code:  
A number that identifies the type of product.

Catalogue number

The label of new products released after October 2010.

The label of products after January 2022.

(Sample label)

## About burr removal shape



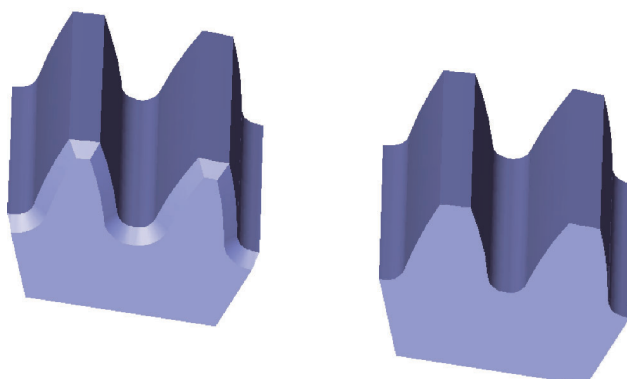

The removal method and shape of burrs generated during the gear cutting process of standard products may differ even for the same product.

(Example) For spur gears



# Introducing food contact blue POM

We have released a POM gear series that is compliant with the Amended Food Sanitation Act (enforced in June 2020) and food contact regulations in the U.S. and EU markets. Since blue is not used in food materials, blue POM gears are suitable for use in food and packaging machines as a measure to prevent the inclusion of foreign objects.

Product name	Spur gear	Helical gear	Rack	Worm gear	Miter gear
Photo					
Module	0.5 to 3.0	1.0 to 3.0	0.5 to 1.0	0.5 to 1.5	0.8 to 3.0
Number of teeth	12 to 120	10 to 26	Overall length: 200 to 500 mm	20 to 100	20 to 30

## Material

The materials of the blue POM gear series are compliant with the following regulations, or compliance with these regulations has been declared by the material manufacturers.

Application	Regulations of each country
Food appliance/ container and packages	Amended Food Sanitation Act (enforced in June 2020 in Japan)
Food contact application	No 10/2011 (EU), FDA (U.S.), NSF 51 (U.S.), 3A-DAIRY (U.S., dairy products), Health Canada (Canada), Japan Hygienic Olefin And Styrene Plastics Association, Ministry of Health, Labor, and Welfare Notification No. 370 (Japan)
Drinking water application	NSF 61 (U.S.), KTW W270 (Germany), WRAS (Britain), ACS (France)

Comparison of performance between blue POM (blue polyacetal resin) and MC nylon

Comparison item	Food contact regulations in the U.S. and EU markets	Amended Food Sanitation Act, enforced in June 2020	Dimensional change		Blue POM gear strength	Ease of additional machining		
			Water absorption % (depends on temperature)	Linear expansion coefficient × 10 <sup>-5</sup> /°C (depends on temperature change) <sup>*2</sup>		Dimensional stability	Degree of aging	Amount of burr
Blue POM	Compliant	Compliant	0.2 (small)	9	About 30% of the strength of MC nylon <sup>*1</sup> Equivalent to the strength of white POM (For details, refer to the allowable transfer capability table.)	Good	Small	Small
MC nylon	Not compliant	Not compliant	0.8 (large)			Unstable	Large	Large

\*1 Care is required when replacing MC nylon with blue POM. \*2 Test specifications: Immerse in 23°C water for 24 hours.

Blue POM has self-lubricating properties. Therefore, you may consider using it without lubrication for low-speed, low-load operation.

Lubrication	No lubrication	Oil lubrication	
Circumferential velocity of spur gears and bevel gears	m/s	6	12
Sliding velocity of worm gears	m/s	1	2.5

Minimum operating limit temperature: -38°C

## Accuracy tolerance

For cut polyacetal gears, the dimensional tolerance for the hole diameter is H9 (machining control tolerance).

Because of the material characteristics, the dimensions of polyacetal products change with time and due to temperature changes. The machining control tolerance is H9, but because KG standard gears are temporarily stocked after being produced, they may be delivered to customers after dimensional changes have occurred. For details, refer to P.55 on "Technical Data (English)."

## Cautions on use:

- Note that this product cannot be used for applications where there is contact with food with an alcohol concentration exceeding 15%.
- Before using this product for production, verify its safety by using the final equipment containing this product under the actual operating conditions.
- The blue POM gear series is produced in an environment with the possibility of exposure to cutting fluids or other such substances.

Marking paint for checking the tooth contact may remain on the product, but it does not adversely affect operation.



# Production of small precision gears

(custom made)

Supported from module 0.2

Ideal for robots, medical equipment, precision equipment, etc.

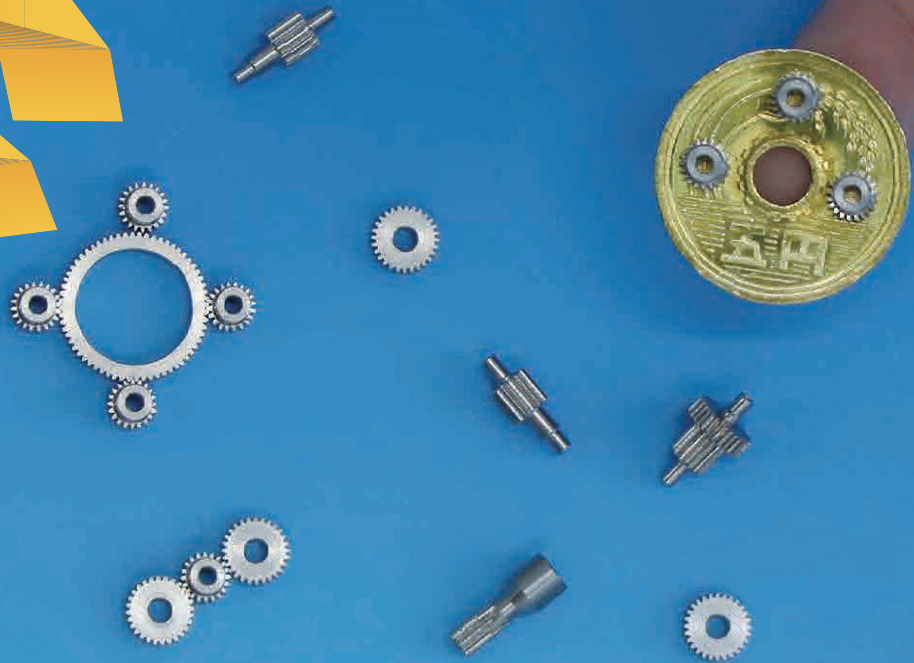

Reference table of specs that can be supported by small precision gears

Compatible with small precision gears

	Gear type	Accuracy grade	Module	Number of teeth	Maximum dimensions
1	Spur gear	JIS class N8 or below (Tooth cutting finish)	0.2 or more	13 or more	Φ 1.0 or more
		JIS class N5 or below (Tooth grinding finish)	0.3 or more	30 or more	Φ 3.0 or more
2	Helical gear	JIS class N8 or below (Tooth cutting finish)	0.2 or more	10 or more	Φ 1.0 or more
		JIS class N5 or below (Tooth grinding finish)	0.3 or more	28 or more	Φ 3.0 or more
3	Rack gear	Tooth cutting finish	0.2 or more	—	—
4	Straight Miter gear / Bevel gear	JIS class 3 or below (Tooth cutting finish)	0.3 or more	20 or more	Φ 1.0 or more
5	Spiral Miter gear / Bevel gear	JIS class 3 or below (Tooth cutting finish)	0.8 or more	20 or more	Φ 1.0 or more
		JIS class 1 or below (Tooth grinding finish)	0.8 or more	20 or more	Φ 1.0 or more
6	Worm	Tooth cutting finish	0.5 or more	—	Need to discuss
		Tooth grinding finish	0.5 or more	—	Need to discuss
7	Worm Wheel	Tooth cutting finish	0.5 or more	18 or more	Φ 1.0 or more

※ The accuracy grade of gears is based on the use of suitable materials.  
 ※ Please contact us for available materials and heat treatments.

 **KYOUIKU GEAR MFG.CO.,LTD. (KG STOCK GEARS)**

Overseas Sales Department

Email: [export@kkgear.co.jp](mailto:export@kkgear.co.jp)

<https://www.kkgear.co.jp/en/>



EN KG WEB



Further  
improvement of  
tooth surface  
roughness

## High-precision tooth polish grinding gears

Accuracy grade JIS B1702-1: Class N4 to N5

**High efficiency**

Reduction of  
meshing friction

**High strength**

Improved pitting  
resistance  
(tooth surface damage)

**Low noise**

Reduction of gear noise  
(vibration noise generated  
during meshing)

# A cutting-edge generating gear grinding machine REISHAUER RZ 260 4.0 has introduced.

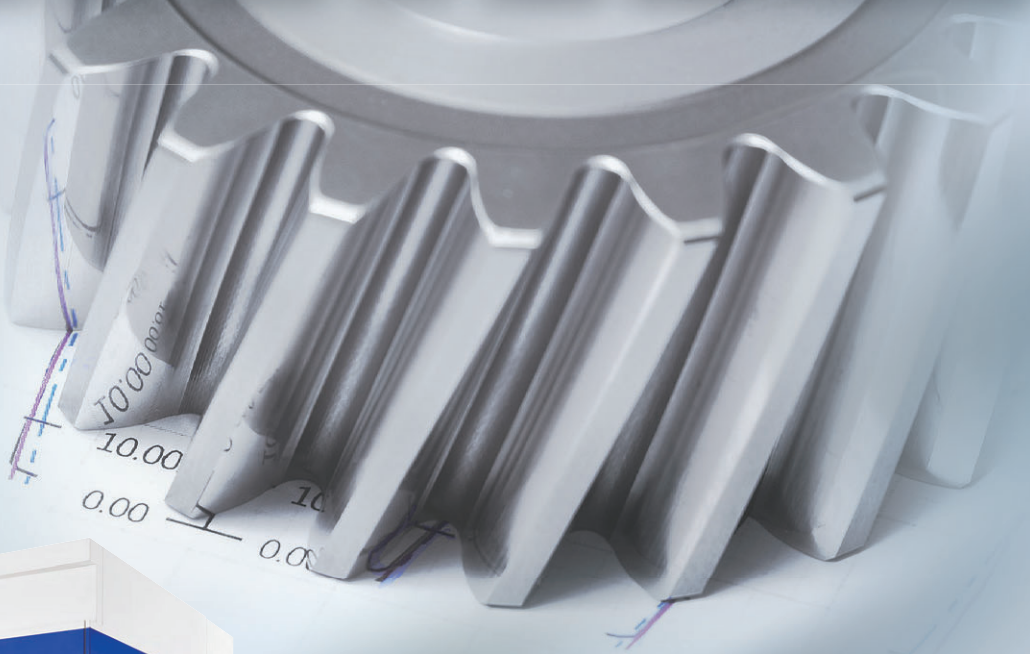

### Main expected uses

For Electric Vehicle,  
Clean room environment, robots,  
Medical equipment,  
Machine tool related, etc.

We manufacture polish grinding gears as custom-made.

# REISHAUER

Overseas Sales Department

Email: [export@kggear.co.jp](mailto:export@kggear.co.jp)

<https://www.kggear.co.jp/en/>



**KYOUIKU GEAR MFG.CO.,LTD.**  
(KG STOCK GEARS)



EN KG WEB

# Overview of processing specifications

	Tooth ground products	Tooth polished products
Compatible gear types	Spur gears and Helical gears	
Module size	m = 0.5 to 3	m = 1.5 to 3
Gear accuracy grade	JIS B 1702-1 class N4 to N5	
Tip diameter	ø20 to ø260	ø40 to ø260
Tooth surface roughness (tooth profile direction)	Ra 0.32 to 0.5	<b>Ra 0.10 to 0.2</b>

## Example of measurement data

### Tooth ground products

部品名	No1
測定種別	粗さ測定
測定長さ	2.0mm
カットオフ波長	0.25mm
測定倍率	× 5K
測定速度	0.06mm/s
カットオフ種別	ガウシアン

#### Right flank

Ra	0.3187 $\mu\text{m}$
Ramax	0.4545 $\mu\text{m}$
Rz	2.0740 $\mu\text{m}$
*Rz. J94	1.4480 $\mu\text{m}$

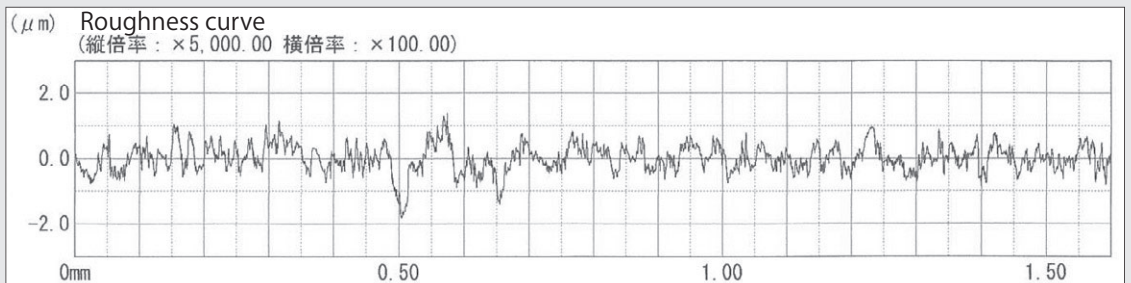

#### Left flank

Ra	0.2232 $\mu\text{m}$
Ramax	0.2609 $\mu\text{m}$
Rz	1.5420 $\mu\text{m}$
Rz. J94	1.0910 $\mu\text{m}$

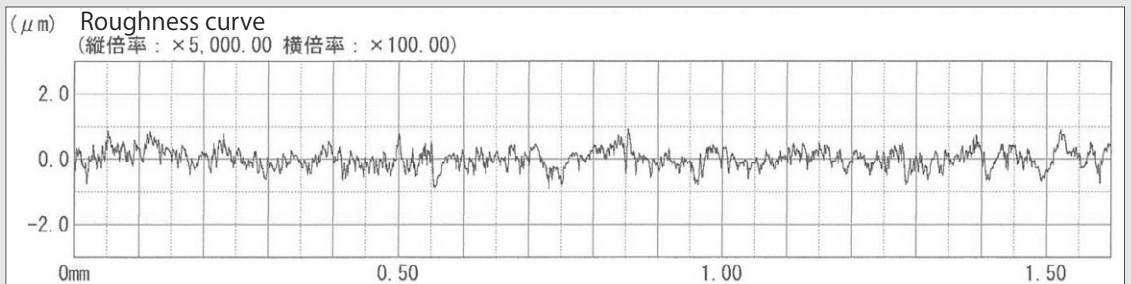

### Tooth polished products

部品名	No2
測定種別	粗さ測定
測定長さ	2.0mm
カットオフ波長	0.25mm
測定倍率	× 5K
測定速度	0.06mm/s
カットオフ種別	ガウシアン

#### Right flank

Ra	0.0977 $\mu\text{m}$
Ramax	0.1385 $\mu\text{m}$
Rz	0.6230 $\mu\text{m}$
*Rz. J94	0.3678 $\mu\text{m}$

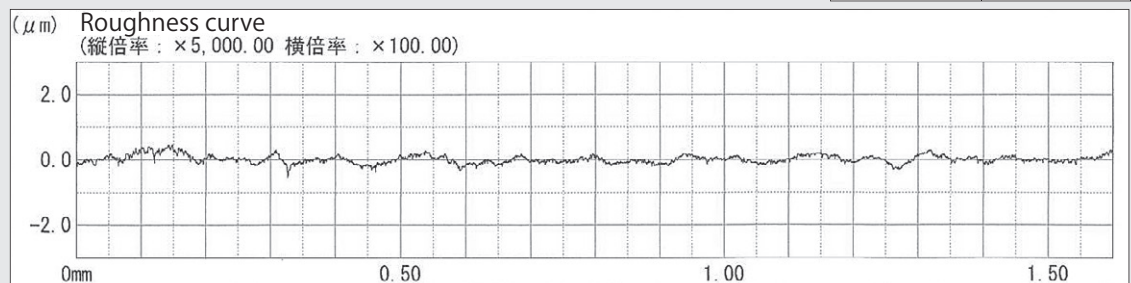

#### Left flank

Ra	0.1197 $\mu\text{m}$
Ramax	0.1642 $\mu\text{m}$
Rz	0.6630 $\mu\text{m}$
*Rz. J94	0.4570 $\mu\text{m}$

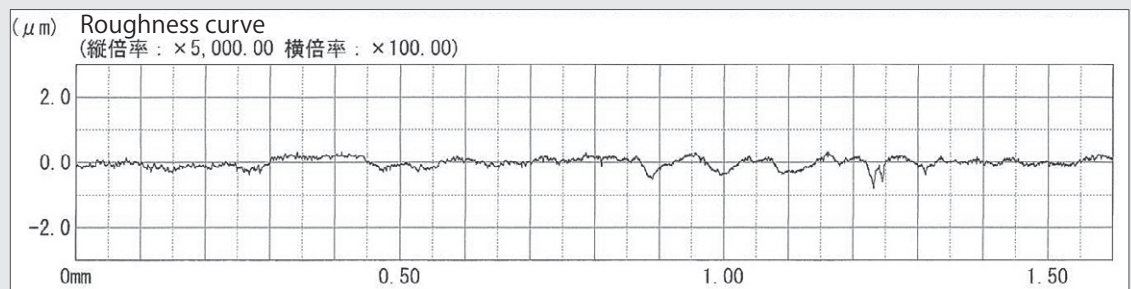

# Gear Drawing CAD data download

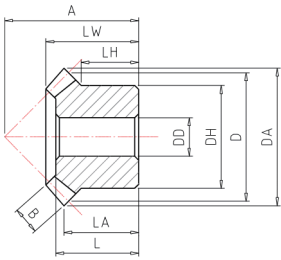
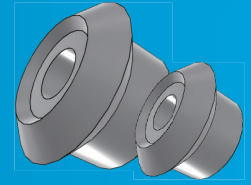

Features	
Product search	You can search KG standard gears you need. You can also check our recommend products.
Creating drawings for additional machining	You can change the shape to meet your needs.
CAD data download	2 D
	3 D

## Access to KG web page

Click the left picture in the web page.



### ① Select the type of gear.

Select the gear type first, like **Spur Gears Bevel Gears...**

The page to download CAD data will be shown.

In this case, Module and Number of teeth are selected.  
Select from pull-down list.

### ② Click "Search" button.

### ③ Select the catalogue number.

The product list will be shown.  
Click the catalogue number you need.

If you cannot find the catalogue number you look for, add search conditions and click "Search" again.  
Or you can check next pages.

ID	Catalog Number	Module	Number of Teeth	Material	Shape	Heat Treatment	Ground Teeth Surface	Backlash	Bore / Shaft Diameter	Face Width	Tapped Holes / Key Way
1	<a href="#">S1D30B*0805</a>	1.00	30	POM	B	-	Cut	-	5	8.0	Set Screw
2	<a href="#">S1D30B-0808</a>	1.00	30	POM	B	-	Cut	-	8	8.0	-
9	<a href="#">S1S30A=1212</a>	1.00	30	S45C	A	-	Cut	-	12	12.0	Key Way
10	<a href="#">S1S30B-0806</a>	1.00	30	S45C	B	-	Cut	-	6	8.0	-

Showing 1 to 10 of 30 entries

Previous 1 2 3 Next

### ④ Check the basic specs.

The basic specs for the product you selected will be shown.

Double check the specs and the catalogue number, and click "Additional Machining · CAD" button.

At the bottom of the page, related products, like similar products and mating gears, will be shown. You can also refer them.

Catalog Number **S1D30B\*0805**

ID	Catalog Number	Gear type	Material	Face Width	Bore / Shaft Diameter	Tapped Holes / Key Way	System of accuracy (JIS B 1702-1 / ISO) ※Spur Gear System of accuracy (JIS B 1704) ※Bevel Gear
1	<a href="#">S1D30B-0808</a>	Spur Gears	POM	8.0	8	-	class 9 - 10
2	<a href="#">S1D630B+1010</a>	Spur Gears	POM	10.0	10	Set Screw	class 9 - 10

Showing 1 to 10 of 29 entries

Previous 1 2 3 Next

You can access to the download page through our web site or below two-dimensional code.



日本語ページ



中文页面



English

### ⑤ Check the detailed specs of the gear

The detailed specs of the standard gear you selected will be shown.

In this page, you can set specs for additional machining, generate data and select languages.

\*Drawings will be generated only in Japanese.

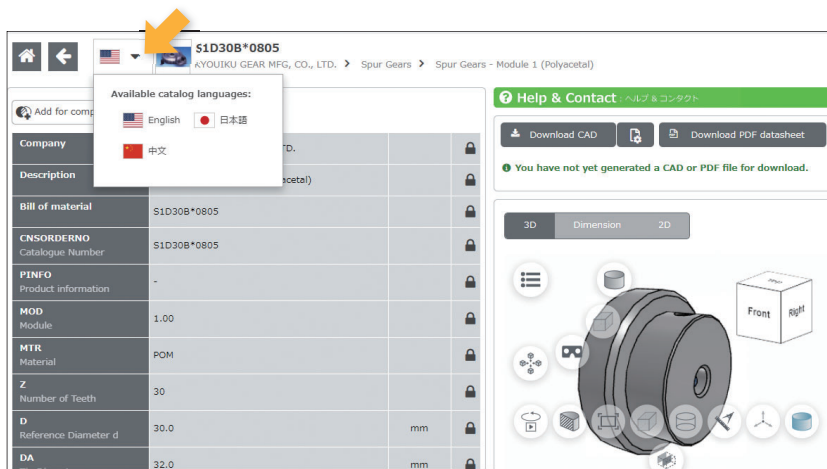

### ⑥ Set additional machining

In this page, you can set for additional machining, like changing bore dia., adding taps and modifying boss shape.

Note:

The categories with this padlock mark cannot be changed. Some gears cannot be modified.

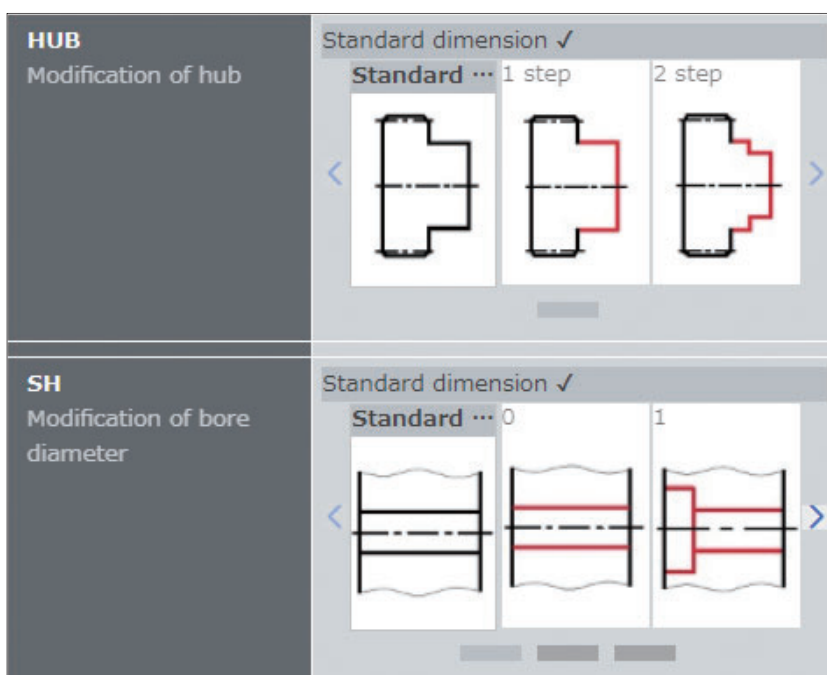

### ⑦ Start generating data.

If you determine the specs including the additional machining, click "Download CAD" button.

If you need to change data format after you have already downloaded, click this button.

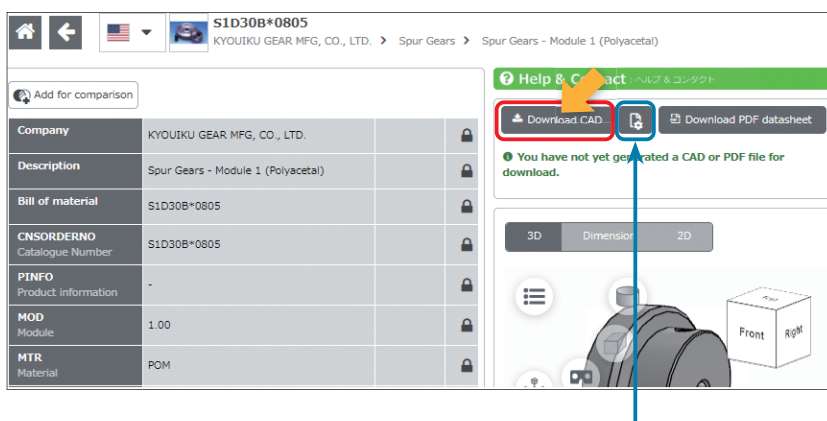

# Gear Drawing CAD data download

## ⑧ Select data format.

The page to choose data format will be shown.

Select data format, like 2D or 3D, and select extension data you prefer.

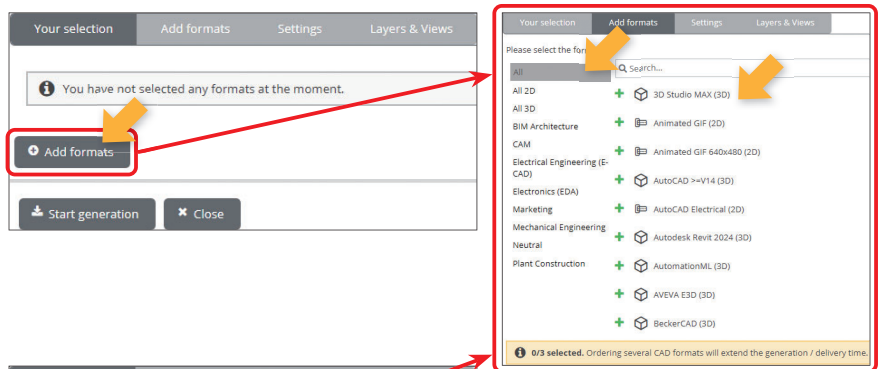

## ⑨ Add formats

Confirmation screen for data format will be shown.

In this case, 3D studio is selected. You can add both 2D and 3D data by following the same procedure. You can add several data by "Add formats".

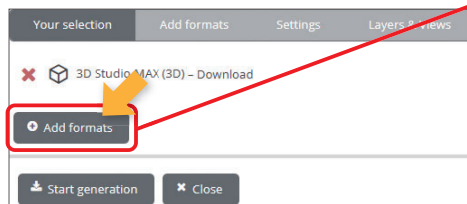

## ⑩ Check the contents.

After you check that you chose all format you need, click "Start generation" button.

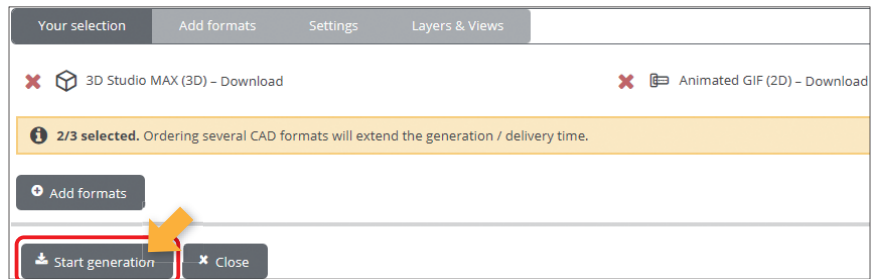

## ⑪ Download

Download screen will be shown after data generation has completed.

Click "Download" button to start.

\*There is a possibility that the download starts once you click "Start generation" button in ⑩.

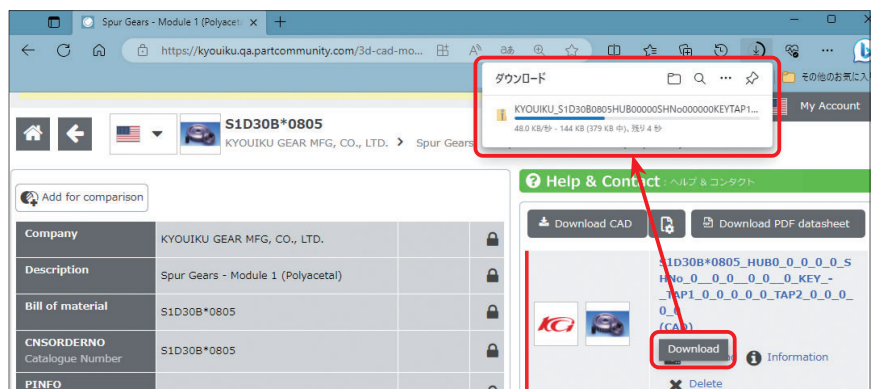

# GEAR BOXES

## HY-BOX

## B-BOX®

## W-BOX

## B-SET

Trademark registered

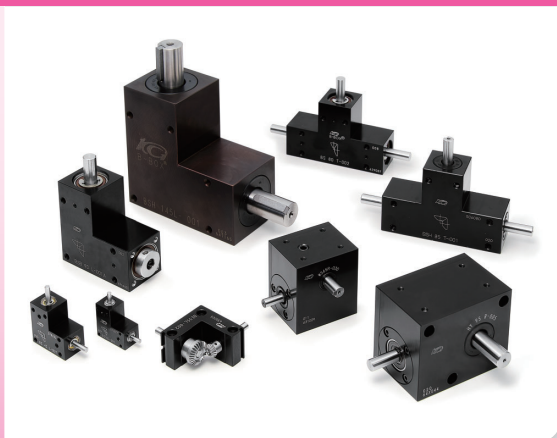







※ These are samples.

### How to Read Catalogue Numbers

**BSB 105 L - 001 A**

Gear type	Distance from body reference plane to shaft end surface	Axis position and overall shape		Ratio (pinion : gear)	Shaft and hole shape
HY : Hypoid gearbox BS : Bevel gearbox BSB : Bevel gearbox (hollow shaft type) BSH : Bevel gearbox (reinforced type) BE : Bevel gearbox (economy type) WS : Worm gearbox	Unit: mm	R : Box shape (output shaft is on the right side) L : L shape T : T shape		001 → 1 : 1 002 → 1 : 2 005 → 1 : 5 010 → 1 : 10	BSB series : A : Small hole type B : Large hole type  BE series A : Thin shaft type B : Thick shaft type

Catalogue number	HY-BOX	BS-BOX	BSB-BOX	BSH-BOX	B-SET	WS-BOX
Shape						
Page	P. 38	P. 40	P. 42	P. 44	P. 46	P. 48
Material	Body: Aluminum Shaft: SCM435/440, S45C	Body: Aluminum Shaft: SUS303	Body: Aluminum Shaft: SUS303	Body: Aluminum or FC250 Shaft: SUS303, S45C	Body: Aluminum Shaft: SUS303	Body: Aluminum Shaft: S45C
Axis position and overall shape	Shaft twisted	L shape, T shape	L shape	L shape, T shape	L shape	Shaft twisted
Backlash	20'	15' to 25'	15'	10' to 15'	Sensory inspection	30' to 45'
Type of gear used	Hypoid gear	Straight bevel gear	Straight bevel gear	Spiral bevel gear	Straight bevel gear	Worm gear

## About Our GEARBOXES

	Series code	Gear type	Page
HY-BOX	HY	Hypoid gear	P. 31 P. 38
B-BOX	BS	Straight bevel gear	P. 31, 32 P. 40
	BSB	Straight bevel gear	P. 31, 32 P. 42
	BSH	Spiral bevel gear	P. 31, 32 P. 44
B-SET	BE	Straight bevel gear	P. 32, 33 P. 46
WS-BOX	WS	Worm Worm wheel	P. 34, 35 P. 48

### 1. Features

- 1) Compact and simple design
- 2) Sealed gearboxes with high dust resistance (except B-SET)
- 3) Low operating vibration and noise with high-precision gears
- 4) Easy installation with mounting screw holes
- 5) Never disassemble Our Gearboxes.

### 2. Cautions on installation

- 1) When securing the gearbox to the mating mounting surface, install the gearbox so that the gear shaft is parallel to the mating shaft and their shaft centers align. A coaxiality of  $\Phi$  0.05 mm or less is recommended.
- 2) It is recommended to use a flexible coupling to couple the gear shaft and mating shaft.
- 3) Use an anti-vibration mounting base.
- 4) It is recommended to install the gearbox in a well-ventilated location.
- 5) Set the overhang load and thrust load of the output shaft (gear side) so that they are within the ranges specified in the catalog.

### 3. Cautions on operation \* Please refer to a few more pages later: Notes on using B-BOX and Notes on using B-SET.

- 1) Do not touch the main body while in operation. Make sure that no foreign object is caught in the key grooves cut in the shaft or shaft stopper ring.
- 2) If any abnormal noise or temperature is observed during operation, immediately stop the machine and suspend operation until the cause is eliminated.
- 3) Warm-up operation is recommended. (Perform warm-up operation for at least 10 minutes with one-third to half of the allowable load.)
- 4) Our BOX products are designed for use as speed-reducing gearboxes. If used as speed-increasing gearboxes, they tend to be noisier and hotter.
- 5) After the start of operation, the backlash tends to increase due to initial wear.
- 6) Depending on the operating conditions and environment, oil components that have separated from the lubricating oil or grease may ooze out.

### 4. Cautions on additional machining \* Please refer to a few more pages later: Notes on using B-SET.

- 1) Before additional machining, take measures to prevent swarf or other foreign objects from getting into the bearings.
- 2) To prevent damage to the oil seals, apply masking to them.
- 3) When machining a shaft, be careful that the shaft or other parts do not deform.
- 4) When you need to machine the body, consult with us in advance as interference with internal parts must be avoided.

### 5. Allowable transfer capability, overhang load, and thrust load

- 1) For the BOX products to work at full performance, use them with a revolutions per minute and torque value not exceeding the values specified in the allowable transfer torque table.
- 2) While a BOX product is in use, avoid subjecting the input shaft (pinion side) to an overhang load or thrust load. If the input or output shaft is subject to an overhang load, provide a separate mechanism to support the load.

# Gearbox information

## Details of BOX products (For details on B-SET, refer to the product details page.)

	Backlash*	Service conditions	Lubrication	Type	Mounting reference plane	Bearing
HY-BOX	20' or less	-10° C to 40° C	Grease sealing	Sealed type	All planes	Ball bearing
B-BOX	15' to 25'	-20° C to 50° C				
BSB-BOX	15' or less					
BSH-BOX	10' to 15'					
WS-BOX	30' to 45'	-10° C to 40° C	Oil lubrication			

\* The backlash values are those at the time of assembly at our factory.  
 When the gear ratio is 1:2, the backlash values are those of the output shaft side.  
 No oil seal is applied to the BS and BSB series. Also, no oil seal is applied to the BE series though it is not included in the table.

## Cautions on HY-BOX

- 1) Before use, make sure that each shaft rotates normally.
- 2) Use a flexible coupling to couple the gear shaft and its mating shaft.
- 3) Use HY-BOX with the overhang load on the output shaft side (gear side) not exceeding the value specified in the catalog.
- 4) After the start of operation, the backlash tends to increase due to initial wear.
- 5) If any abnormal noise is heard, immediately stop the machine and suspend operation until the cause is eliminated.
- 6) HY-BOX does not assume use in special environments. When using HY-BOX in a vacuum or other special environments, consult with us in advance.
- 7) The allowable transfer capability table in the catalog shows the performance as a speed-reducing gearbox. The table is not applicable when HY-BOX is used as a speed-increasing gearbox.

## Cautions on B-BOX

### Input, Gear Ratio, and Gear Layout of B-BOX

Gear ratio (Pinion shaft P : Gear shaft G)	L shape	T shape
<p>When the P shaft is used as the input shaft</p> <p><b>1 : 2</b></p> <p>The rotational direction is not restricted and can be reversed.</p>		
<p><b>1 : 1</b></p> <p>The rotational direction is not restricted and can be reversed.</p>		

Please be aware that this product is subject to dimensional changes without prior notice, to the extent that it does not adversely affect the functionality.



# Gearbox information

CONTENTS

INFORMATION

GEARBOXES

ANTI-BACKLASH  
SPUR GEARS

SPUR GEARS

RACKS

HELICAL GEARS AND  
SCREW GEARS

MITER GEARS

BEVEL GEARS

WORMS AND WORM  
WHEELS

REFERENCES

## Cautions on B-BOX

Never disassemble B-BOX.

Use B-BOX with a transfer torque not exceeding the value specified in the allowable transfer torque table.

Avoid subjecting the shafts to an overhang load during use. However, if the input or output shaft is subject to an overhang load for design reasons, provide a separate mechanism to support the load. (See Fig. 9.)

Be careful not to apply a shock to the shafts or body.

### When installing B-BOX (For effective use of B-BOX)

Warm-up operation is recommended. (Perform warm-up operation for at least 10 minutes with one-third to half of the allowable load.)

◇ Before operation, make sure that each shaft rotates normally by rotating it by hand.

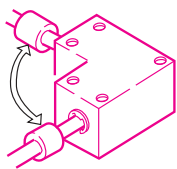

◇ Install B-BOX so that the gear shaft is parallel to the mating shaft and their shaft centers align. Failure to do so may damage the shafts (a coaxiality of  $\phi 0.05$  mm or less is recommended).

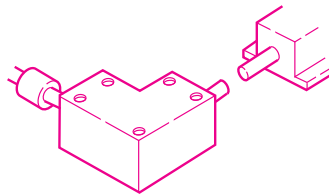

◇ Be careful not to get caught in the exposed parts of the shafts. Also, make sure that no foreign object gets caught in the exposed parts of the shafts.

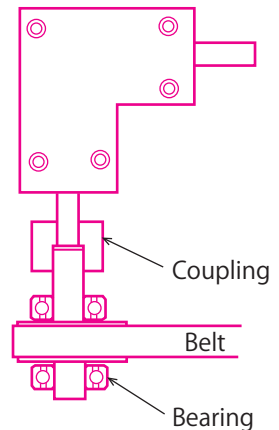
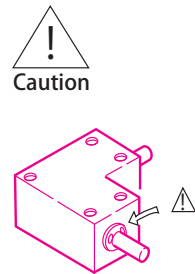

Fig. 9 Example of measure for overhang load

It is recommended to use a flexible coupling to couple the gear shaft and mating shaft.

This product is not a fully sealed type. Avoid using this product where the body is exposed to water, oil, chemicals, or other fluids. When this product is used as a speed-increasing gearbox, it tends to be noisier and get hotter than when it is used as a constant-speed or speed-reducing gearbox.

### During use (Particular attention is required for safety.)

◇ During operation, do not touch this product as doing so is dangerous.  
◇ Make sure that no foreign object gets caught in the exposed parts of the shafts.

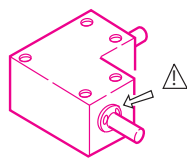

◇ If any abnormal noise or temperature is observed during operation, immediately stop the machine and suspend the operation until the cause is eliminated.

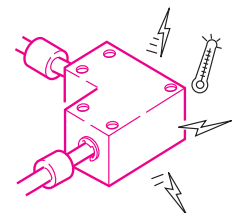

## Cautions on B-SET

### Features of B-SET

- When B-SET is ready for operation, make sure that the provided cover is properly installed onto the main body. If the cover comes off due to vibration or other reasons during operation, add screws, etc. as necessary to firmly secure it. If the cover is damaged or has deteriorated, replace it with a new one. (You can purchase the cover alone.)
- For details, refer to "Notes on Using B-SET" on P. 35.

Backlash	Lubrication	Service conditions	Type	Mounting reference plane	Bearing
Sensory inspection *1	*2	*3	Open type	Both lateral faces	Plain bearing

\*1 Check that the gears rotate normally.

\*2 Before use, apply grease to the tooth surfaces and set the plastic cover.

\*3 The service conditions depend on the performance of the grease you use. Make sure that no grease leaks from the cover at high temperatures.

# Gearbox information

## Cautions on B-SET

Use B-SET with a transfer torque not exceeding the value specified in the allowable transfer capability table.

Avoid subjecting the shafts to an overhang load during use. However, if the input or output shaft is subject to an overhang load for design reasons, provide a separate mechanism to support the load. (See Fig. 10.)

### When installing B-SET (For effective use of B-SET)

- ◇ Before operation, make sure that each shaft rotates normally by rotating it by hand.

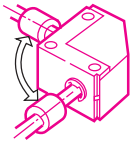

- ◇ Install B-SET so that the gear shaft is parallel to the mating shaft and their shaft centers align. (A coaxiality of  $\phi 0.05$  mm or less is recommended.)

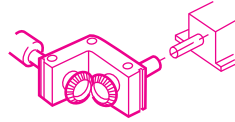

- ◇ Apply grease to the gear teeth periodically. It is recommended to lubricate the bearings with lubricating oil. Make sure that the lubricating oil does not dry out.

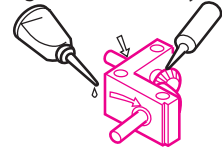

- ◇ Be careful not to get your fingers caught in the gears, shaft stopper rings, or other parts of the B-SET. Also, make sure that no foreign object gets caught in the B-SET.

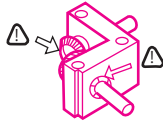

- ◇ When a B-SET is ready for operation, make sure that the provided cover is securely set in the main body.

- ◇ Follow steps ① and ② to install the cover while taking care not to damage it.

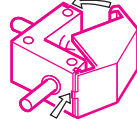

- ② Push the cover until the tab is fully engaged with the groove in the body.

- ① Align the convex part on the cover stopper and concave part on the body.

- ◇ If the cover may come off during operation, use screws or other fasteners to firmly secure it.

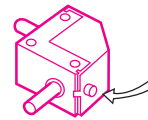

When drilling a screw hole in the body, be careful not to damage the bearing.

Warm-up operation is recommended. (Perform warm-up operation for at least 10 minutes with one-third to half of the allowable load.)

It is recommended to use a flexible coupling to couple the gear shaft and mating shaft.

Make sure that the bearings and teeth are free of dust or other foreign objects.

When B-SET is used as a speed-increasing gearbox, it tends to be noisier and get hotter than when it is used as a constant-speed or speed-reducing gearbox.

### During use (Particular attention is required for safety.)

- ◇ During operation, do not touch the B-SET as doing so is dangerous.
- ◇ Make sure that no foreign object gets caught in the exposed parts of the shafts.

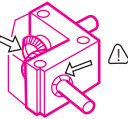

- ◇ If any abnormal noise or temperature is observed during operation, immediately stop the machine and suspend the operation until the cause is eliminated.

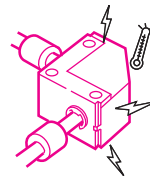

- ◇ If the provided cover is damaged or has deteriorated, replace it with a new one. (You can purchase the cover alone.)

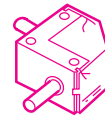

### When performing additional machining

Care is required as additional machining may adversely affect the functionality.

If you have any questions about additional machining, please consult us.

- ◇ Before additional machining, take measures to prevent swarf from getting into the bearings or gears.
- ◇ When making an additional mounting hole, make sure that the hole diameter is less than or equal to the allowable hole diameter specified for additional machining. (See Table 1 on the product description page.)

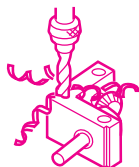

- ◇ When drilling an additional hole in the cover, be sure to place a support plate under the cover.

- Plate a support plate under the cover.

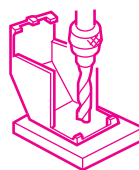

× Failure to use the back plate will damage the cover.

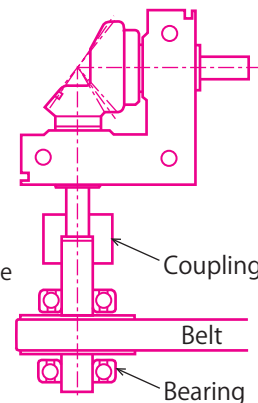
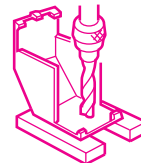

Fig. 10 Example of measure for overhang load

## Cautions on WS-BOX

### 1. Auto lock (self-lock) does not work

To stop the operation completely, provide a separate brake mechanism.

### 2. Warm-up operation

Before using a W-BOX, it is recommended to perform warm-up operation for at least six hours with a load about one-third to half of the normal load.

### 3. When abnormal noise is heard

If unusual noise is heard or vibration increases, immediately stop the machine and suspend the operation until the cause is eliminated. Also, replace the lubricating oil as necessary.

### 4. When W-BOX is abnormally hot

When the room temperature or BOX surface temperature is 80° C or more, suspend the operation. Replace the lubricating oil or check the operating conditions of the W-BOX.

### 5. How to replace the lubricating oil

- \* Perform the first lubricating oil replacement when the cumulative operation time reaches about 50 hours after the start of operation.  
After that, check the oil level and contamination every six months and replace the lubricating oil as necessary.
- \* Replace the lubricating oil when the body temperature and lubricating oil temperature are sufficiently low. Be careful as there is a risk of burn injury.
- \* Replace the lubricating oil with the drain ports at the top and bottom to ensure that the old lubricating oil is drained.
- \* Never replace the lubricating oil using any other than our lubricating oil replacement kit. Doing so may cause damage to the gear tooth surface.

It is recommended to replace the lubricating oil with the WS-BOX removed from the device.

- ① Remove the drain plugs (one at the top and one at the bottom) and drain the old lubricating oil.
- ② Using the wash oil of the lubricating oil replacement kit, remove abrasion powder and foreign objects from the gears.
- ③ Wipe off the remaining wash oil as much as possible.  
If the wash oil is not wiped off sufficiently, the oil level will be too high due to the residual oil and cause oil stain when new lubricating oil is added.
- ④ Close the drain port at the bottom. Wrap the drain plug with an appropriate amount of sealing tape and install the drain plug. Make sure that no oil leaks from the drain port.
- ⑤ Add new lubricating oil from the drain port at the top. Add new lubricating oil until the container is empty.
- ⑥ Close the drain port at the top. Wrap the drain plug with an appropriate amount of sealing tape and install it onto the drain plug. Make sure that no oil leaks from the drain port.
- ⑦ Before installing the WS-BOX to its original position in the device, check that the input and output shafts rotate normally. Double check that no oil leaks from any parts.

\* If anything abnormal is found, suspend the operation and contact us.

## 6. Lubricating oil replacement kit for WS-BOX only

Catalogue number	Amount of oil to be added [ml]	Amount of wash oil [ml]	Total amount of oil
LO – WS55R – 020	3.0	20.0	23.0
LO – WS55R – 030	2.3	20.0	22.3
LO – WS60R – 040	4.5	20.0	24.5
LO – WS60R – 050	2.5	20.0	22.5
LO – WS65R – 020	4.2	20.0	24.2
LO – WS65R – 030	4.5	20.0	24.5
LO – WS75R – 040	6.5	20.0	26.5
LO – WS75R – 050	7.0	20.0	27.0
LO – WS80R – 010	9.0	30.0	39.0
LO – WS80R – 020	7.0	30.0	37.0
LO – WS80R – 030	8.5	30.0	38.5
LO – WS90R – 040	15.0	50.0	65.0
LO – WS90R – 050	19.0	50.0	69.0

\* Oil to be used: Sumigear Oil S0460 (semisynthetic oil)

Use the same oil as the filling oil and wash oil.

\* The oil may leak from the container if stored for a long time.

# About gearbox customization

## 1. Description of Standard Specifications for Customization (Reference Drawing)

Body			
Application	Standard	Strength enhancement	Cleanroom Vacuum
Material	A5052P A5056 A6063 A6061 FC200	S45C SCM435	SUS304 A5052 and others
Surface treatment	Black alumite Black oxide finish	Black oxide finish Electroless nickel plating Raydent treatment	No surface treatment Electroless nickel plating White alumite
Other	-	Shape modification of body Addition of mounting tap holes	

Shaft			
Application	Standard	Strength enhancement	Cleanroom Vacuum
Material	SUS303 S45C	S45C SCM435	SUS304
Heat treatment	-	Induction hardening	-
Other	Key groove D-shape cutting	Stepped shaft, change of shaft length, threading, key groove, D-shape cutting, drilled hole, black oxide finish, electroless nickel plating, Raydent treatment	

\* Machining may be difficult if the parts have been heat treated. For details, contact us.

Sleeve		
Application	Standard	Cleanroom Vacuum
Material	S45C	SUS304

Bearing		
Application	Standard	Cleanroom Vacuum
Material	Steel	Stainless steel Coating
Other	Grease designated by manufacturer	Change of grease specifications (Designate a grease.)

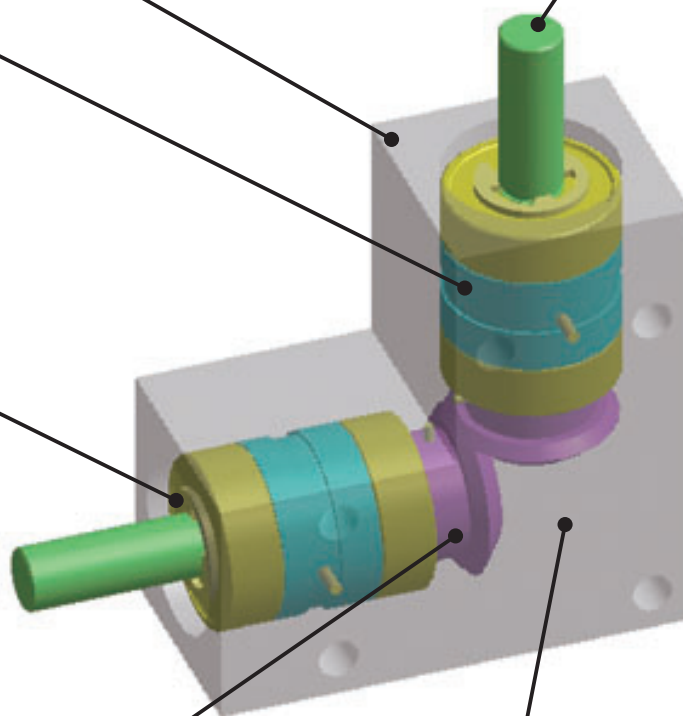

Gear			
Application	Standard	Strength enhancement	Cleanroom Vacuum
Material	S45C SCM435 SCM415	S45C SCM435 SCM415	SUS304
Heat treatment	No heat treatment, or Isonite treatment, induction hardening, carburizing	Isonite treatment, induction hardening, or carburizing	-
Other	Fasteners: Spring pin, solid pin		

Grease			
Application	Standard	Cleanroom Vacuum	Ambient temperature
Type	Common gear grease (#0, #1)	Designated grease	

\* Oil lubrication is used for W-BOX.

\* For special usage or additional machining, consult with us.

# About gearbox customization

## 2. Example of Customized Products

### Cost reduction

= Reduction of development time + Labor and time required for design and production · Reduction of risks



Electroless nickel plating of body



Raydent treatment of body

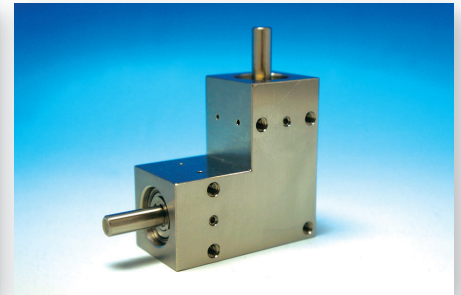

Stainless steel (entire body) + Additional drilling (body)

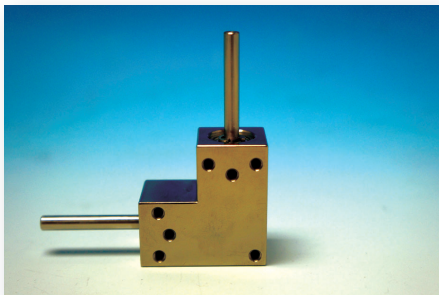

Change of shaft length

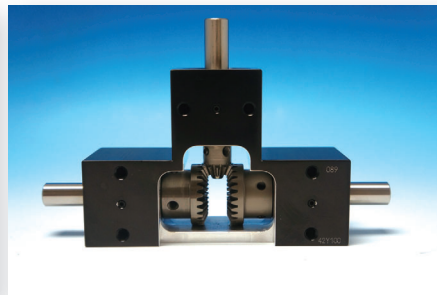

Three-shaft divided type



Additional machining of body

## 3. Three-shaft divided type

### What is the three-shaft divided type?

#### Standard T-shaped product

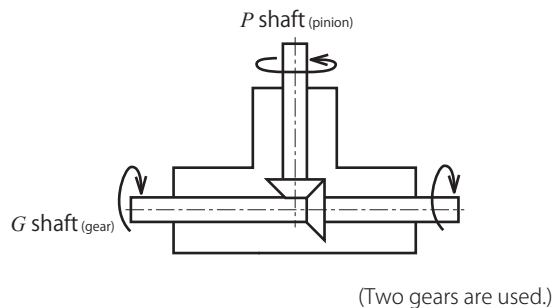

When viewed from the shaft end, the G shaft rotates in the opposite direction.

#### Customized three-shaft divided type

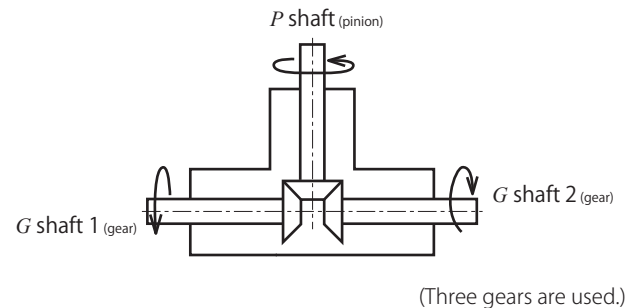

When viewed from the shaft end, G shafts 1 and 2 rotate in the same direction.

\* The three-shaft divided-type product has a larger backlash than the standard product. For details, contact us.

\* For customized specifications and additional machining (e.g., service conditions, oil leak prevention, installation of a shaft of another diameter), consult with us.



### Hypoid gears used

Catalogue number	Pinion	Gear
HY70R-005	m 0.75 × 8T	m 0.75 × 40T
HY90R-010	m 0.71 × 7T	m 0.71 × 70T
HY95R-005	m 1.1 × 8T	m 1.1 × 40T
HY120R-010	m 1.0 × 7T	m 1.0 × 70T
HY125R-005	m 1.5 × 8T	m 1.5 × 40T
HY150R-010	m 1.45 × 6T	m 1.45 × 60T

Type of gear used: Hypoid gear

How to read notation: "m1.0 × 20T" means that the module is 1, and the number of teeth is 20.

Unit: mm

Body material	Body surface treatment	Input shaft material	Output shaft material	Lubrication method	Backlash
Aluminum (A5052P/A5056)	Black alumite	SCM435/440	S45C	Grease sealing	20' or less

★ For the KG-BOX, the pinion gear is used as the input shaft, and the gear shaft is used as the output shaft.

★ Rotational direction of each shaft: For the HY-BOX, when the input shaft is rotated clockwise with the shaft end facing the front, the output shaft rotates counter-clockwise. The rotational direction can be reversed.

★ The backlash is the value on the output shaft side when the input shaft is fixed.

Catalogue number	Gear ratio	Shaft diameter														
		A	B	C	D	E	F	G	Input shaft		Output shaft		J	K	L	M
									$\phi H(h7)$	$\phi I(h7)$	$\phi H(h7)$	$\phi I(h7)$				
<i>u</i>	<i>A</i>	<i>B</i>	<i>C</i>	<i>D</i>	<i>E</i>	<i>F</i>	<i>G</i>	$\phi H(h7)$	$\phi I(h7)$	$\phi H(h7)$	$\phi I(h7)$	<i>J</i>	<i>K</i>	<i>L</i>	<i>M</i>	
<b>HY 70R – 005</b>	1 : 5	70	58	45	55	40	15	18	$\phi 6$	$\phi 8$	$\phi 6$	$\phi 8$	20	17.5	36	22.5
<b>HY 90R – 010</b>	1 : 10	90	68	60	75	50	15	18	$\phi 6$	$\phi 8$	$\phi 6$	$\phi 8$	25	20	47	30
<b>HY 95R – 005</b>	1 : 5	95	75	60	75	50	20	25	$\phi 8$	$\phi 12$	$\phi 8$	$\phi 12$	25	20	49	30
<b>HY 120R – 010</b>	1 : 10	120	80	80	100	55	20	25	$\phi 8$	$\phi 12$	$\phi 8$	$\phi 12$	27.5	25	62	40
<b>HY 125R – 005</b>	1 : 5	125	85	80	100	55	25	30	$\phi 12$	$\phi 15$	$\phi 12$	$\phi 15$	27.5	30	65	40
<b>HY 150R – 010</b>	1 : 10	150	90	95	125	60	25	30	$\phi 12$	$\phi 15$	$\phi 12$	$\phi 15$	30	32.5	77	47.5

Catalogue number	Allowable input torque for different input revolutions per minute (Unit: N-cm)							
	100rpm	250rpm	500rpm	800rpm	1,000rpm	1,500rpm	2,000rpm	2,500rpm
<b>HY 70R – 005</b>	76.0	71.8	66.0	59.0	53.9	44.2	36.6	28.4
<b>HY 90R – 010</b>	75.8	70.8	63.8	56.0	50.7	41.3	34.3	27.3
<b>HY 95R – 005</b>	247.4	232.1	211.8	187.7	170.3	137.7	112.6	86.0
<b>HY 120R – 010</b>	186.3	172.7	155.7	136.6	123.5	100.0	82.7	65.0
<b>HY 125R – 005</b>	414.8	400.6	377.6	345.4	319.8	266.9	223.0	173.9
<b>HY 150R – 010</b>	357.2	336.1	307.3	272.1	246.5	197.5	159.2	118.1



2D • 3D CAD

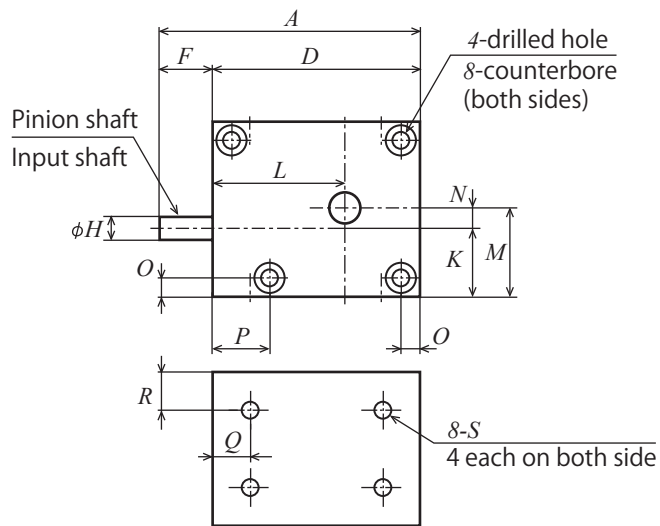
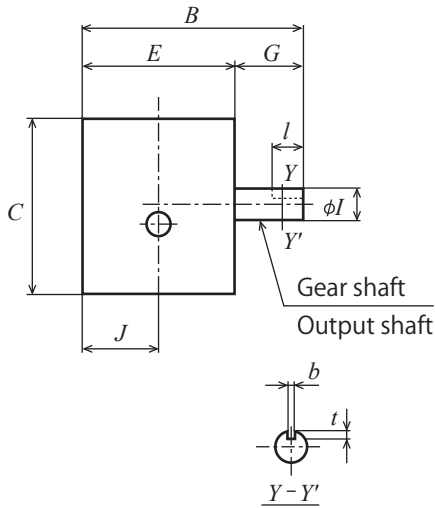

Offset	N	O	P	Q	R	Mounting screw		Drilled hole and counterbore			Key groove			Back-lash ( ' )	Allowable overhang load Output shaft (N)	Allowable thrust load Output shaft (N)	Weight W(kg)	Catalogue number
						8-S	Depth	Drilled hole	Counterbore diameter	Counterbore depth	b	t	l					
5	5	14	10	10	8-M3	5	φ3.2	φ6.5	3.2	-	-	-	20	19	13	0.3	<b>HY 70R – 005</b>	
10	7	26	12	12	8-M4	6	φ4.2	φ8.0	4.3	-	-	-		19	20	0.6	<b>HY 90R – 010</b>	
10	7	28	12	12	8-M4	6	φ4.2	φ8.0	4.3	-	-	-		39	35	0.7	<b>HY 95R – 005</b>	
15	10	27	15	12	8-M5	8	φ5.2	φ9.5	5.3	-	-	-		39	35	1.3	<b>HY 120R – 010</b>	
10	10	27	18	12	8-M5	8	φ5.2	φ9.5	5.3	5	3	20		54	42	1.4	<b>HY 125R – 005</b>	
15	10	27	20	12	8-M5	8	φ5.2	φ9.5	5.3	5	3	20		54	42	2.2	<b>HY 150R – 010</b>	

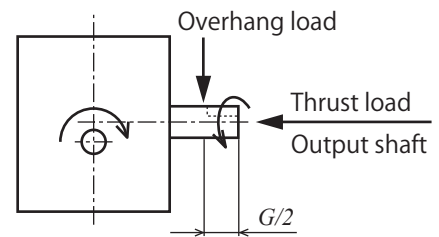
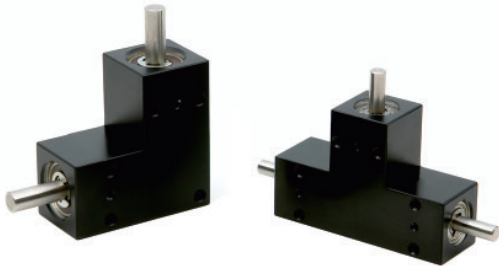

Fig. Overhang load position, thrust load, and shaft rotation direction



## Straight bevel gears used



Catalogue number	Pinion	Gear
BS35L-001	m 0.4 × 20T	m 0.4 × 20T
BS45L-001/BS45T-001	m 0.5 × 20T	m 0.5 × 20T
BS65L-001/BS65T-001	m 0.8 × 20T	m 0.8 × 20T
BS80L-001/BS80T-001	m 1.0 × 20T	m 1.0 × 20T
BS90L-001/BS90T-001	m 1.25 × 20T	m 1.25 × 20T
BS105L-001/BS105T-001	m 1.5 × 20T	m 1.5 × 20T
BS65L-002/BS65T-002	m 0.6 × 14T	m 0.6 × 28T
BS80L-002/BS80T-002	m 0.8 × 13T	m 0.8 × 26T
BS90L-002/BS90T-002	m 1.0 × 13T	m 1.0 × 26T
BS105L-002/BS105T-002	m 1.25 × 13T	m 1.25 × 26T

Type of gear used: Straight bevel gear

How to read notation: "m1.0 × 20T" means that the module is 1, and the number of teeth is 20.

Unit: mm

Body material	Body surface treatment	Input shaft material	Output shaft material	Lubrication method	Backlash
Aluminum (A5056/A6061/A6063)	Black alumite	SUS303	SUS303	Grease sealing	15' to 25'

★ For the KG-BOX, the pinion gear is used as the input shaft, and the gear shaft is used as the output shaft.

★ The backlash is the value on the output shaft side when the input shaft is fixed. For the amount of backlash, see the sections describing the respective catalogue numbers.

★ The D-shaped shafts are out of phase.

★ Avoid subjecting the shafts to an overhang load during use. If a shaft is subject to an overhang load or thrust load, provide a separate mechanism to support the load.

★ For customized specifications and additional machining (e.g., service conditions, oil leak prevention, installation of a shaft of another diameter), consult with us.

Catalogue number	Type	Gear ratio							Input/ output shaft diameter	
			$u$	$Z$	$Y$	$\square C$	$A$	$B$		$\phi D(h7)$
<b>BS 35 L – 001</b>	L	1 : 1	-	-	-	14	35	27	$\phi 3$	8
<b>BS 45 L – 001</b>			-	-	-	18	45	33	$\phi 4$	12
<b>BS 65 L – 001</b>			-	-	-	25	65	50	$\phi 6$	15
<b>BS 80 L – 001</b>			-	-	-	30	80	60	$\phi 8$	20
<b>BS 90 L – 001</b>			-	-	-	35	90	70	$\phi 10$	20
<b>BS 105 L – 001</b>			-	-	-	40	105	80	$\phi 12$	25
<b>BS 65 L – 002</b>	L	1 : 2	-	-	-	25	65	50	$\phi 6$	15
<b>BS 80 L – 002</b>			-	-	-	30	80	60	$\phi 8$	20
<b>BS 90 L – 002</b>			-	-	-	35	90	70	$\phi 10$	20
<b>BS 105 L – 002</b>			-	-	-	40	105	80	$\phi 12$	25
<b>BS 45 T – 001</b>	T	1 : 1	72	48	-	18	45	33	$\phi 4$	12
<b>BS 65 T – 001</b>			105	75	-	25	65	50	$\phi 6$	15
<b>BS 80 T – 001</b>			130	90	-	30	80	60	$\phi 8$	20
<b>BS 90 T – 001</b>			145	105	-	35	90	70	$\phi 10$	20
<b>BS 105 T – 001</b>			170	120	-	40	105	80	$\phi 12$	25
<b>BS 65 T – 002</b>			T	1 : 2	105	75	-	25	65	50
<b>BS 80 T – 002</b>	130	90			-	30	80	60	$\phi 8$	20
<b>BS 90 T – 002</b>	145	105			-	35	90	70	$\phi 10$	20
<b>BS 105 T – 002</b>	170	120			-	40	105	80	$\phi 12$	25

Catalogue number		Allowable input torque for different input revolutions per minute (Unit: N-cm)							
		50rpm	100rpm	250rpm	500rpm	800rpm	1,000rpm	1,500rpm	2,000rpm
<b>BS 35 L – 001</b>	-	7.1	7.0	6.8	6.5	6.2	6.0	5.5	5.3
<b>BS 45 L – 001</b>	<b>BS 45 T – 001</b>	18.7	18.6	18.1	17.3	16.5	16.0	15.0	14.0
<b>BS 65 L – 001</b>	<b>BS 65 T – 001</b>	73.7	72.6	69.8	65.6	61.0	58.4	52.6	47.9
<b>BS 80 L – 001</b>	<b>BS 80 T – 001</b>	137.9	135.6	129.1	119.5	109.7	104.0	92.0	82.6
<b>BS 90 L – 001</b>	<b>BS 90 T – 001</b>	271.8	266.1	250.4	228.0	205.8	193.3	167.8	148.2
<b>BS 105L – 001</b>	<b>BS 105T – 001</b>	442.6	431.6	401.6	360.0	320.1	298.1	254.3	221.9
<b>BS 65 L – 002</b>	<b>BS 65 T – 002</b>	20.2	20.1	19.7	19.0	18.3	17.8	16.7	15.7
<b>BS 80 L – 002</b>	<b>BS 80 T – 002</b>	39.8	39.5	38.4	36.8	35.1	34.0	31.5	29.5
<b>BS 90 L – 002</b>	<b>BS 90 T – 002</b>	77.6	76.7	74.3	70.5	66.4	64.0	58.6	54.0
<b>BS 105 L – 002</b>	<b>BS 105T – 002</b>	141.5	139.6	134.0	125.7	116.9	111.7	100.7	91.5



2D • 3D CAD

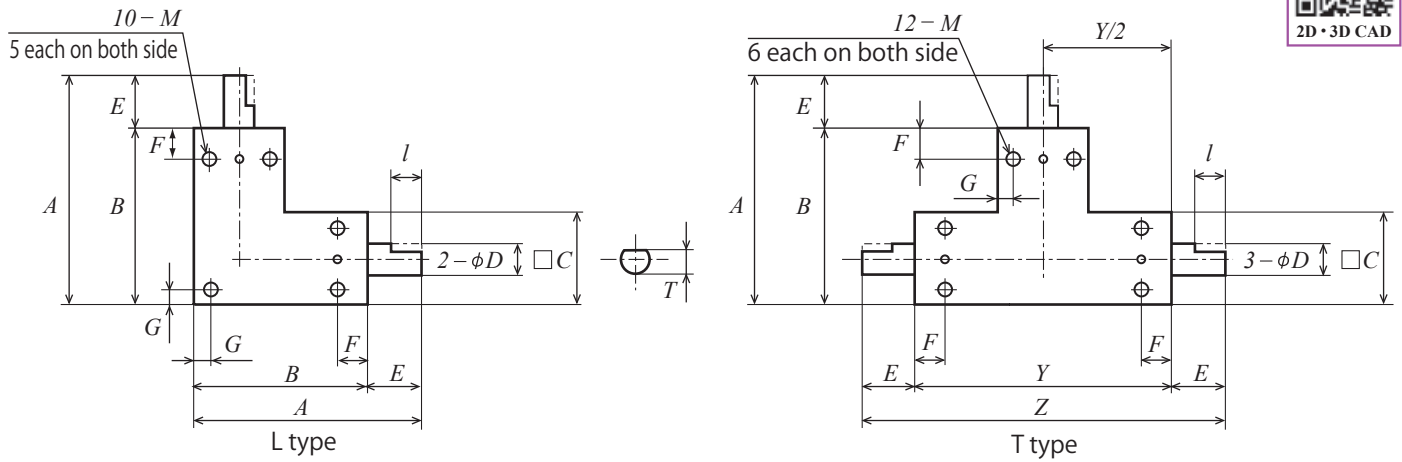

F	G	Shaft end shape			Mounting screw		Backlash ( ' )	Weight W(g)	Catalogue number
		$\phi D$	T	l	M	Depth			
4	2	D	2.7	5	10-M2	4	25	27	BS 35 L – 001
5	3	D	3.3	8	10-M3	4	20	55	BS 45 L – 001
12	3.5	$\phi$	-	-	10-M4	6	15	175	BS 65 L – 001
15	5	$\phi$	-	-	10-M5	6		290	BS 80 L – 001
15	5	$\phi$	-	-	10-M5	7		496	BS 90 L – 001
20	5	$\phi$	-	-	10-M6	7	725	BS 105 L – 001	
12	3.5	$\phi$	-	-	10-M4	6	20	175	BS 65 L – 002
15	5	$\phi$	-	-	10-M5	6		290	BS 80 L – 002
15	5	$\phi$	-	-	10-M5	7		496	BS 90 L – 002
20	5	$\phi$	-	-	10-M6	7	725	BS 105 L – 002	
5	3	D	3.3	8	12-M3	4	20	75	BS 45 T – 001
12	3.5	$\phi$	-	-	12-M4	6	15	246	BS 65 T – 001
15	5	$\phi$	-	-	12-M5	6		410	BS 80 T – 001
15	5	$\phi$	-	-	12-M5	7		679	BS 90 T – 001
20	5	$\phi$	-	-	12-M6	7	991	BS 105 T – 001	
12	3.5	$\phi$	-	-	12-M4	6	20	246	BS 65 T – 002
15	5	$\phi$	-	-	12-M5	6		410	BS 80 T – 002
15	5	$\phi$	-	-	12-M5	7		679	BS 90 T – 002
20	5	$\phi$	-	-	12-M6	7	991	BS 105 T – 002	

## Standard T-shaped product

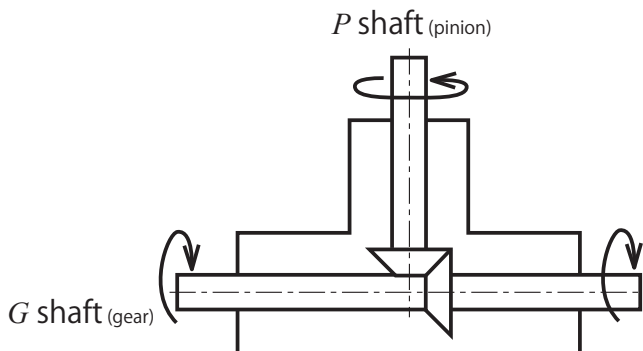

# BSB-BOX® Bevel gearbox hollow shaft type



## Straight bevel gears used

Catalogue number	Pinion	Gear
BSB65L-001A/B	m 0.8 × 20T	m 0.8 × 20T
BSB80L-001A/B	m 1.0 × 20T	m 1.0 × 20T
BSB90L-001A/B	m 1.25 × 20T	m 1.25 × 20T
BSB105L-001A/B	m 1.5 × 20T	m 1.5 × 20T

Type of gear used: Straight bevel gear

How to read notation: "m1.0 × 20T" means that the module is 1, and the number of teeth is 20.

Unit: mm

Body material	Body surface treatment	Input shaft material	Output shaft material	Lubrication method	Backlash
Aluminum (A5056/A6061/A6063)	Black alumite	SUS303	SUS303	Grease sealing	15' or less

★ For the KG-BOX, the pinion gear is used as the input shaft, and the gear shaft is used as the output shaft.

★ The products with a catalogue number that ends with [B] have a slightly larger hole than those with a catalogue number that ends with [A] (1 to 2 mm).

★ Cautions on coupling a hollow shaft of BSB (LB type):

① When coupling a round shaft, provide two flat surfaces (spaced 120°). Reason: The contact area between the round shaft surface and tapped hole can be increased by providing flat surfaces.

② If a shaft has a stepped portion, provide a conner large radius to avoid stress concentration.

★ The backlash is the value on the output shaft side when the input shaft is fixed.

★ For customized specifications and additional machining (e.g., service conditions, oil leak prevention, installation of a shaft of another diameter), consult with us.

Catalogue number	Type	Gear ratio <i>u</i>	□ <i>C</i>	<i>A</i>	<i>B</i>	Shaft diameter $\phi D(H7)$	Hole diameter		<i>E</i>	<i>I</i>
							$\phi H(H7)$	Effective depth		
<b>BSB 65L – 001A</b>	LB	1 : 1	25	65	50	$\phi 6$	$\phi 5$	15	15	5
<b>BSB 65L – 001B</b>			25	65	50	$\phi 6$	$\phi 6$	15	15	5
<b>BSB 80L – 001A</b>			30	80	60	$\phi 8$	$\phi 6$	19	20	5
<b>BSB 80L – 001B</b>			30	80	60	$\phi 8$	$\phi 8$	19	20	5
<b>BSB 90L – 001A</b>			35	90	70	$\phi 10$	$\phi 8$	19	20	6
<b>BSB 90L – 001B</b>			35	90	70	$\phi 10$	$\phi 10$	19	20	6
<b>BSB 105L – 001A</b>			40	105	80	$\phi 12$	$\phi 10$	23	25	6
<b>BSB 105L – 001B</b>			40	105	80	$\phi 12$	$\phi 12$	23	25	6

Catalogue number	Allowable input torque for different input revolutions per minute (Unit: N-cm)							
	50rpm	100rpm	250rpm	500rpm	800rpm	1,000rpm	1,500rpm	2,000rpm
<b>BSB 65L – 001A/B</b>	73.7	72.6	69.8	65.6	61.0	58.4	52.6	47.9
<b>BSB 80L – 001A/B</b>	137.9	135.6	129.1	119.5	109.7	104.0	92.0	82.6
<b>BSB 90L – 001A/B</b>	271.8	266.1	250.4	228.0	205.8	193.3	167.8	148.2
<b>BSB 105L – 001A/B</b>	442.6	431.6	401.6	360.0	320.1	298.1	254.3	221.9



2D • 3D CAD

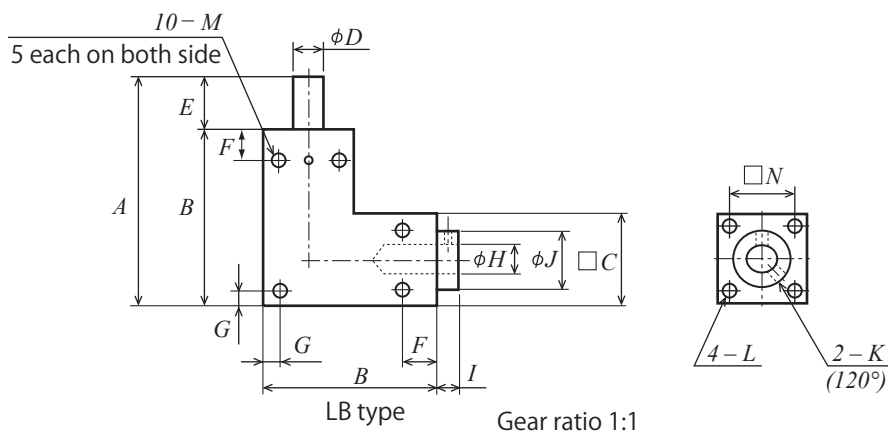

$\phi J$	2-K(120°)	F	G	Mounting screw		Mounting screw			Backlash ( ' )	Weight W(g)	Catalogue number
				10-M	Depth	4-L	$\square N$	Depth			
16	2-M3	12	3.5	10-M4	6	4-M3	19	6	15	169	<b>BSB 65L – 001A</b>
16	2-M3	12	3.5	10-M4	6	4-M3	19	6		167	<b>BSB 65L – 001B</b>
19	2-M3	15	5	10-M5	6	4-M3	23	8		293	<b>BSB 80L – 001A</b>
19	2-M3	15	5	10-M5	6	4-M3	23	8		289	<b>BSB 80L – 001B</b>
21	2-M4	15	5	10-M5	7	4-M4	25	8		465	<b>BSB 90L – 001A</b>
21	2-M4	15	5	10-M5	7	4-M4	25	8		460	<b>BSB 90L – 001B</b>
26	2-M4	20	5	10-M6	7	4-M4	30	10		722	<b>BSB 105L – 001A</b>
26	2-M4	20	5	10-M6	7	4-M4	30	10		713	<b>BSB 105L – 001B</b>



Assembly example of B-BOX and motor

To install a motor onto the BSB series, a flange is required.

# BSH-BOX® Bevel gearbox reinforced type

CONTENTS  
INFORMATION  
GEARBOXES  
ANTI-BACKLASH SPUR GEARS  
SPUR GEARS  
RACKS  
HELICAL GEARS AND SCREW GEARS  
MITER GEARS  
BEVEL GEARS  
WORMS AND WORM WHEELS  
REFERENCES



## Spiral bevel gears used

Catalogue number	Pinion	Gear
BSH70L-001/BSH70T-001	m 0.8 × 19T	m 0.8 × 19T
BSH85L-001/BSH85T-001	m 1.0 × 19T	m 1.0 × 19T
BSH95L-001/BSH95T-001	m 1.25 × 18T	m 1.25 × 18T
BSH115L-001/BSH115T-001	m 1.5 × 19T	m 1.5 × 19T
BSH120L-001/BSH120T-001	m 1.5 × 19T	m 1.5 × 19T
BSH140L-001/BSH140T-001	m 2.0 × 19T	m 2.0 × 19T
BSH145L-001/BSH145T-001	m 2.0 × 19T	m 2.0 × 19T
BSH165L-001	m 2.5 × 19T	m 2.5 × 19T
BSH170L-001	m 2.5 × 19T	m 2.5 × 19T

Type of gear used: Spiral bevel gear

How to read notation: "m1.0 × 20T" means that the module is 1, and the number of teeth is 20.

Unit: mm

Body material	Body surface treatment	Input shaft material	Output shaft material	Lubrication method	Backlash
Aluminum (A6061/A6063) Plain cast iron EC FC250	Black alumite, ferrosoferric oxide coating	SUS303/S45C	SUS303/S45C	Grease sealing	10' to 15'

★ For the KG-BOX, the pinion gear is used as the input shaft, and the gear shaft is used as the output shaft.

★ The backlash is the value on the output shaft side when the input shaft is fixed. For the amount of backlash, see the sections describing the respective catalogue numbers.

★ The key grooves are out of phase.

★ For customized specifications and additional machining (e.g., operating conditions, oil leak prevention, installation of a shaft of another diameter), consult with us.

Catalogue number	Material			Type	Gear ratio	Z	Y	□ C	A	B	Input/ output shaft di- ameter φD(h7)	E
	Body	Body surface treatment	Shaft									
<b>BSH 70L – 001</b>	AL	Alumite	SUS303	L	1 : 1	-	-	27	70	54	φ 6	16
<b>BSH 85L – 001</b>						-	-	32	85	64	φ 8	21
<b>BSH 95L – 001</b>						-	-	36	95	72	φ10	23
<b>BSH 115L – 001</b>	FC	Ferrosoferric oxide coating	S45C	L	1 : 1	-	-	45	115	90	φ12	25
<b>BSH 120L – 001</b>						-	-	45	120	90	φ15	30
<b>BSH 140L – 001</b>						-	-	55	140	110	φ15	30
<b>BSH 145L – 001</b>						-	-	55	145	110	φ20	35
<b>BSH 165L – 001</b>						-	-	65	165	130	φ20	35
<b>BSH 170L – 001</b>						-	-	65	170	130	φ25	40
<b>BSH 70T – 001</b>	AL	Alumite	SUS303	T	1 : 1	113	81	27	70	54	φ 6	16
<b>BSH 85T – 001</b>						138	96	32	85	64	φ 8	21
<b>BSH 95T – 001</b>						154	108	36	95	72	φ10	23
<b>BSH 115T – 001</b>	FC	Ferrosoferric oxide coating	S45C	T	1 : 1	143	93	45	115	90	φ12	25
<b>BSH 120T – 001</b>						153	93	45	120	90	φ15	30
<b>BSH 140T – 001</b>						175	115	55	140	110	φ15	30
<b>BSH 145T – 001</b>						185	115	55	145	110	φ20	35

Catalogue number		Allowable input torque for different input revolutions per minute (Unit: N · m)							
		250rpm	500rpm	800rpm	1000rpm	1500rpm	2000rpm	2500rpm	3000rpm
<b>BSH 70L – 001</b>	<b>BSH 70T – 001</b>	0.89	0.89	0.89	0.89	0.86	0.81	0.77	0.73
<b>BSH 85L – 001</b>	<b>BSH 85T – 001</b>	1.95	1.95	1.95	1.95	1.81	1.69	1.59	1.50
<b>BSH 95L – 001</b>	<b>BSH 95T – 001</b>	3.68	3.68	3.68	3.58	3.30	3.04	2.85	2.77
<b>BSH 115L – 001</b>	<b>BSH 115T – 001</b>	5.23	5.23	5.15	5.01	4.69	4.40	4.25	4.13
<b>BSH 120L – 001</b>	<b>BSH 120T – 001</b>	5.23	5.23	5.15	5.01	4.69	4.40	4.25	4.13
<b>BSH 140L – 001</b>	<b>BSH 140T – 001</b>	13.30	13.30	12.62	12.17	11.18	10.70	10.30	-
<b>BSH 145L – 001</b>	<b>BSH 145T – 001</b>	13.30	13.30	12.62	12.17	11.18	10.70	10.30	-
<b>BSH 165L – 001</b>	-	26.15	25.63	23.93	22.86	21.25	20.26	-	-
<b>BSH 170L – 001</b>	-	26.15	25.63	23.93	22.86	21.25	20.26	-	-



2D • 3D CAD

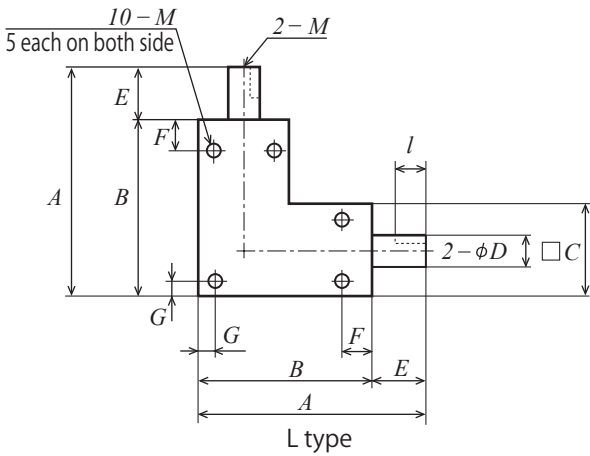

L type

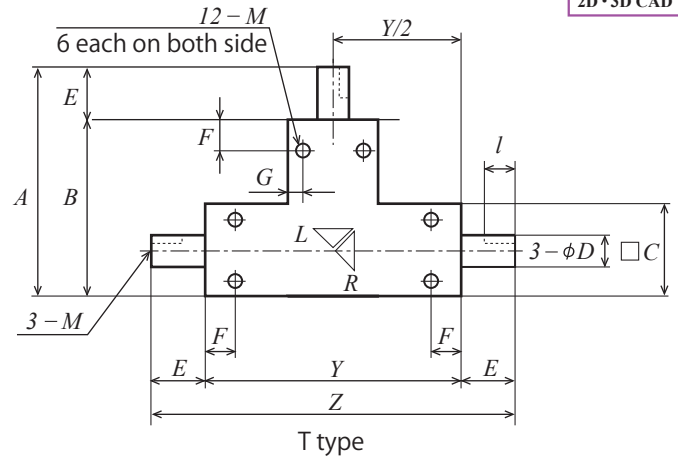

T type

F	G	Key groove			Mounting screw		Shaft end screw		Back-lash ( ' )	Allowable overhang load (N)	Allowable thrust load (N)	Weight W(kg)	Catalogue number
		b	t	l	M	Depth	M	Depth					
9	4	-	-	-	10-M4	6	-	-	15	25	22	0.2	BSH 70L – 001
10	5	3	1.8	14	10-M5	7	-	-		36	39	0.4	BSH 85L – 001
13	5	3	1.8	15	10-M5	8	-	-		58	63	0.5	BSH 95L – 001
20	5	4	2.5	20	10-M5	12	2-M4	8	10	83	70	1.8	BSH 115L – 001
20	5	5	3.0	25	10-M5	12	2-M4	8		83	70	1.8	BSH 120L – 001
25	6	5	3.0	25	10-M6	13	2-M5	10		166	135	3.1	BSH 140L – 001
25	6	6	3.5	30	10-M6	13	2-M5	10		166	135	3.2	BSH 145L – 001
25	7	6	3.5	30	10-M6	14	2-M5	12		245	212	5.4	BSH 165L – 001
25	7	8	4.0	35	10-M6	14	2-M5	12		245	212	5.5	BSH 170L – 001
9	4	-	-	-	12-M4	6	-	-		15	25	22	0.3
10	5	3	1.8	14	12-M5	7	-	-	36		39	0.5	BSH 85T – 001
13	5	3	1.8	15	12-M5	8	-	-	58		63	0.7	BSH 95T – 001
20	5	4	2.5	20	12-M5	12	3-M4	8	10	83	70	2.0	BSH 115T – 001
20	5	5	3.0	25	12-M5	12	3-M4	8		83	70	2.0	BSH 120T – 001
25	6	5	3.0	25	12-M6	13	3-M5	10		166	135	3.4	BSH 140T – 001
25	6	6	3.5	30	12-M6	13	3-M5	10		166	135	3.5	BSH 145T – 001

### Standard T-shaped product

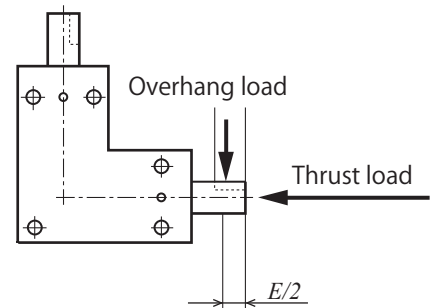
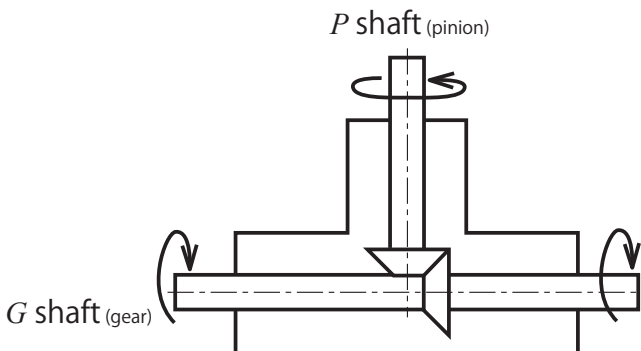
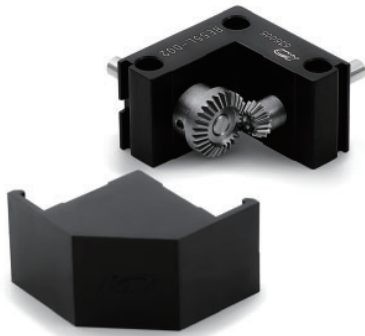

Fig. Overhang load position and thrust load



### Straight bevel gears used

Catalogue number	Pinion	Gear
BE40L-001	m 0.5 × 20T	m 0.5 × 20T
BE55L-001	m 0.8 × 20T	m 0.8 × 20T
BE70L-001A/BE70L-001B	m 1.0 × 20T	m 1.0 × 20T
BE88L-001A/BE88L-001B	m 1.5 × 20T	m 1.5 × 20T
BE55L-002	m 0.6 × 14T	m 0.6 × 28T
BE70L-002A/BE70L-002B	m 0.8 × 13T	m 0.8 × 26T
BE88L-002A/BE88L-002B	m 1.25 × 13T	m 1.25 × 26T

Type of gear used: Straight bevel gear

How to read notation: "m1.0 × 20T" means that the module is 1, and the number of teeth is 20.

Unit: mm

Body material	Body surface treatment	Input shaft material	Output shaft material	Lubrication method	Backlash
Aluminum (A5056/A6063)	Black alumite	SUS303	SUS303	Periodic greasing of tooth surfaces	Sensory inspection ①

★ For the KG-BOX, the pinion gear is used as the input shaft, and the gear shaft is used as the output shaft.

★ S45C is used as the gear material. A plastic cover comes with the gearbox.

★ Difference between products with a catalogue number that ends with A and B: the B type has a larger shaft diameter than type A by 2 mm.

★ Mounting bolt holes 3-K can be used as pilot holes for tapping. (See the dimension table below and the blue text in the dimensional code table.)

① This is an economy type product. Sensory inspection is performed for backlash instead of detailed measurement.

Catalogue number	Gear ratio										
		<i>u</i>	<i>A</i>	<i>B</i>	<i>C</i>	Input/output shaft diameter $\phi D(h8)$	<i>E</i>	<i>F</i>	<i>G</i>	<i>H</i>	<i>I</i>
BE40 L - 001	1 : 1		40	30	10	$\phi 4$	10	5	4.5	20.5	15
BE55 L - 001			55	40	13	$\phi 5$	15	6.5	5	28.5	21.5
BE70 L - 001A			70	50	16	$\phi 6$	20	8	6	36	27
BE70 L - 001B			70	50	16	$\phi 8$	20	8	6	36	27
BE88 L - 001A			88	63	20	$\phi 10$	25	10	7	46	33
BE88 L - 001B			88	63	20	$\phi 12$	25	10	7	46	33
BE55 L - 002	1 : 2		55	40	13	$\phi 5$	15	6.5	5	28.5	21.5
BE70 L - 002A			70	50	16	$\phi 6$	20	8	6	36	27
BE70 L - 002B			70	50	16	$\phi 8$	20	8	6	36	27
BE88 L - 002A			88	63	20	$\phi 10$	25	10	7	46	33
BE88 L - 002B			88	63	20	$\phi 12$	25	10	7	46	33

Catalogue number	Allowable input torque for different input revolutions per minute (Unit: N·cm)			
	50rpm	100rpm	250rpm	500rpm
BE40 L - 001	9.8	9.7	9.4	9.0
BE55 L - 001	38.6	38.0	36.5	34.3
BE70 L - 001A	72.3	71.0	67.6	62.6
BE70 L - 001B	72.3	71.0	67.6	62.6
BE88 L - 001A	232.3	226.5	210.8	188.9
BE88 L - 001B	232.3	226.5	210.8	188.9
BE55 L - 002	10.5	10.4	10.2	9.9
BE70 L - 002A	20.7	20.6	20.1	19.3
BE70 L - 002B	20.7	20.6	20.1	19.3
BE88 L - 002A	74.2	73.2	70.3	65.9
BE88 L - 002B	74.2	73.2	70.3	65.9

表 1

Catalogue number	Drilled hole	Applicable hex socket bolt	For additional tapping	Allowable hole diameter for additional machining
BE 40 L	$\phi 3.4$	M3	M4	Additional machining not allowed
BE 55 L	$\phi 3.4$	M3	M4	$\phi 5$ or less
BE 70 L	$\phi 4.3$	M4	M5	$\phi 6$ or less
BE 88 L	$\phi 5.2$	M5	M6	$\phi 8$ or less



2D • 3D CAD

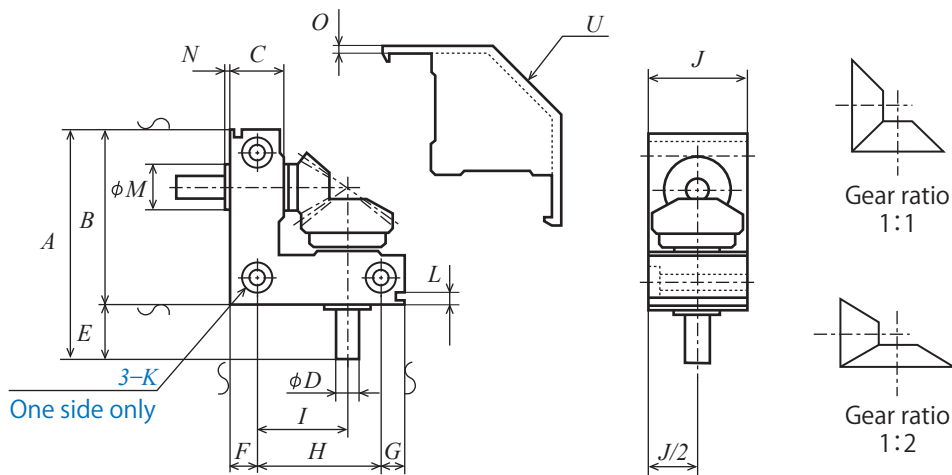

J	Drilled hole and counterbore 3-K			L	M	N	O	U	Weight W(g)	Catalogue number
	Drilled hole	Counterbore diameter	Counterbore depth							
18	φ3.4	φ6.5	3.5	2.5	φ 7	2.1	1.7	C13	30	<b>BE40 L – 001</b>
25	φ3.4	φ6.5	3.5	4	φ 9	1.8	1.9	C16	85	<b>BE55 L – 001</b>
30	φ4.3	φ8	4.5	4.5	φ11	1.8	2.1	C20	155	<b>BE70 L – 001A</b>
30	φ4.3	φ8	4.5	4.5	φ14	2	2.1	C20	170	<b>BE70 L – 001B</b>
40	φ5.2	φ9.5	5.5	5	φ18	2	2.1	C27	375	<b>BE88 L – 001A</b>
40	φ5.2	φ9.5	5.5	5	φ19	2.2	2.1	C27	380	<b>BE88 L – 001B</b>
25	φ3.4	φ6.5	3.5	4	φ 9	1.8	1.9	C16	80	<b>BE55 L – 002</b>
30	φ4.3	φ8	4.5	4.5	φ11	1.8	2.1	C20	140	<b>BE70 L – 002A</b>
30	φ4.3	φ8	4.5	4.5	φ14	2	2.1	C20	165	<b>BE70 L – 002B</b>
40	φ5.2	φ9.5	5.5	5	φ18	2	2.1	C27	345	<b>BE88 L – 002A</b>
40	φ5.2	φ9.5	5.5	5	φ19	2.2	2.1	C27	375	<b>BE88 L – 002B</b>

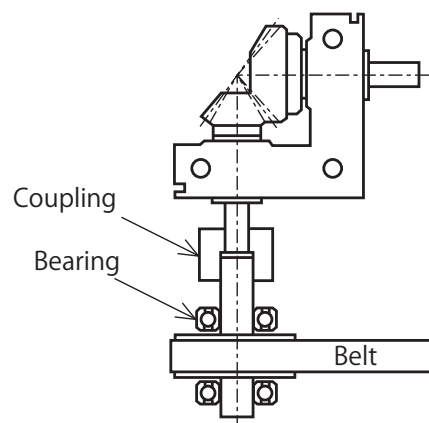

Reference drawing 1





## Worms and worm wheels used

Catalogue number	Worm	Worm wheel
WS55R-020	m 0.5 × 1T	m 0.5 × 20T
WS55R-030	m 0.5 × 1T	m 0.5 × 30T
WS60R-040	m 0.5 × 1T	m 0.5 × 40T
WS60R-050	m 0.5 × 1T	m 0.5 × 50T
WS65R-020	m 0.8 × 1T	m 0.8 × 20T
WS65R-030	m 0.8 × 1T	m 0.8 × 30T
WS75R-040	m 0.8 × 1T	m 0.8 × 40T
WS75R-050	m 0.8 × 1T	m 0.8 × 50T
WS80R-010	m 1.0 × 2T	m 1.0 × 20T
WS80R-020	m 1.0 × 1T	m 1.0 × 20T
WS80R-030	m 1.0 × 1T	m 1.0 × 30T
WS90R-040	m 1.0 × 1T	m 1.0 × 40T
WS90R-050	m 1.0 × 1T	m 1.0 × 50T

Type of gear used: Worm and worm wheel

How to read notation: "m1.0 × 20T" means that the module is 1, and the number of teeth is 20.

Unit: mm

Body material	Body surface treatment	Input shaft material	Output shaft material	Lubrication method	Backlash
Aluminum (A5052P/A5056)	Black alumite	S45C	S45C	Oil lubrication	30' to 45'

★ Our WS-BOX uses a worm shaft as the input shaft ( $\phi H$ ) and a wheel shaft ( $\phi I$ ) as the output shaft.

★ Our WS-BOX is designed based on the assumption that it will be used with the input shaft on bottom and the output shaft on top. When it is not used with the input shaft on bottom and the output shaft on top, the transfer torque must be 75% or less of the values specified in the "Allowable input torque table" and "Allowable output torque table."

★ The backlash is the value on the output shaft side when the input shaft is fixed. For the amount of backlash, see the sections describing the respective catalogue numbers.

★ Rotational direction of each shaft: For the W-BOX, when the input shaft is rotated clockwise with the shaft end facing front, the output shaft also rotates clockwise. The rotational direction can be reversed.

Catalogue number	Gear ratio	Body size					Shaft length		Shaft diameter		Center distance
		$A$	$B$	$C$	$D$	$E$	$F$	$G$	Input shaft $\phi H(h7)$	Output shaft $\phi I(h7)$	
<b>WS 55R – 020</b>	1 : 20	55	45	45	45	35	10	10	$\phi 5$	$\phi 8$	9.5
<b>WS 55R – 030</b>	1 : 30	55	45	45	45	35	10	10	$\phi 5$	$\phi 8$	12
<b>WS 60R – 040</b>	1 : 40	60	50	55	50	40	10	10	$\phi 5$	$\phi 8$	14.5
<b>WS 60R – 050</b>	1 : 50	60	50	55	50	40	10	10	$\phi 5$	$\phi 8$	17
<b>WS 65R – 020</b>	1 : 20	65	55	55	50	40	15	15	$\phi 6$	$\phi 8$	13.2
<b>WS 65R – 030</b>	1 : 30	65	55	55	50	40	15	15	$\phi 6$	$\phi 8$	17.2
<b>WS 75R – 040</b>	1 : 40	75	60	70	60	45	15	15	$\phi 6$	$\phi 10$	21.2
<b>WS 75R – 050</b>	1 : 50	75	60	70	60	45	15	15	$\phi 6$	$\phi 10$	25.2
<b>WS 80R – 010</b>	1 : 10	80	65	70	60	45	20	20	$\phi 8$	$\phi 10$	18
<b>WS 80R – 020</b>	1 : 20	80	65	70	60	45	20	20	$\phi 8$	$\phi 10$	18
<b>WS 80R – 030</b>	1 : 30	80	65	70	60	45	20	20	$\phi 8$	$\phi 12$	23
<b>WS 90R – 040</b>	1 : 40	90	75	85	70	50	20	25	$\phi 8$	$\phi 15$	28
<b>WS 90R – 050</b>	1 : 50	90	75	85	70	50	20	25	$\phi 8$	$\phi 15$	33

Catalogue number	Allowable input torque for different input revolutions per minute (Unit: N·cm)							
	50rpm	100rpm	500rpm	1,000rpm	1,500rpm	2,000rpm	2,500rpm	3,000rpm
<b>WS 55R – 020</b>	4.0	3.5	2.0	1.5	1.2	1.0	0.9	0.9
<b>WS 55R – 030</b>	5.7	4.9	3.0	2.2	1.8	1.6	1.4	1.3
<b>WS 60R – 040</b>	7.3	6.3	4.0	3.0	2.5	2.1	1.9	1.8
<b>WS 60R – 050</b>	8.9	7.7	4.9	3.7	3.0	2.7	2.2	2.2
<b>WS 65R – 020</b>	9.9	8.5	5.1	3.9	3.1	2.7	2.5	2.3
<b>WS 65R – 030</b>	14.1	12.3	7.6	5.7	4.8	4.2	3.7	3.5
<b>WS 75R – 040</b>	18.0	15.8	9.9	7.5	6.3	5.5	5.0	4.6
<b>WS 75R – 050</b>	21.9	18.9	12.3	9.3	7.9	6.9	6.3	5.8
<b>WS 80R – 010</b>	34.5	29.7	16.9	12.7	10.4	9.1	8.1	7.3
<b>WS 80R – 020</b>	24.9	21.4	12.0	8.9	7.2	6.3	5.6	5.1
<b>WS 80R – 030</b>	35.2	30.6	17.8	13.1	10.8	9.5	8.5	7.8
<b>WS 90R – 040</b>	45.1	39.0	23.3	17.2	14.3	12.6	11.3	10.4
<b>WS 90R – 050</b>	54.7	47.4	28.6	21.4	17.7	15.6	14.1	12.9



2D • 3D CAD

Recommended amount of lubricating oil (ml)	Catalogue number
3.0	WS55R-020
2.3	WS55R-030
4.5	WS60R-040
2.5	WS60R-050
4.2	WS65R-020
4.5	WS65R-030
6.5	WS75R-040
7.0	WS75R-050
9.0	WS80R-010
7.0	WS80R-020
8.5	WS80R-030
15.0	WS90R-040
19.0	WS90R-050

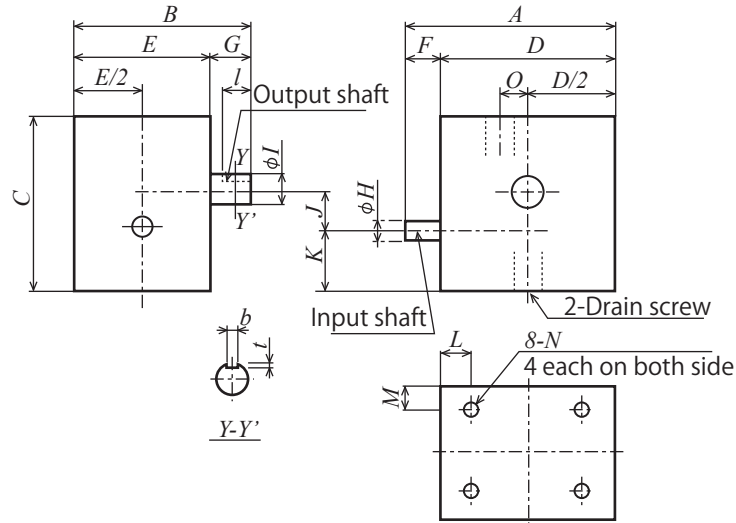

K	L	M	Mounting screw		Key groove			Drain screw O	Backlash ( ' )	Allowable overhang load Output shaft (N)	Allowable thrust load Output shaft (N)	Weight W(kg)	Catalogue number
			8-N	Depth	b	t	l						
16.5	8	7	8-M3	6	3	1.8	8	0	45	24	4.4	0.23	<b>WS 55R – 020</b>
16.5	8	7	8-M3	6	3	1.8	8	0	45	24	6.3	0.23	<b>WS 55R – 030</b>
20	8	8	8-M3	6	3	1.8	8	0	30	24	8.1	0.34	<b>WS 60R – 040</b>
19	8	8	8-M3	6	3	1.8	8	8	30	24	9.9	0.36	<b>WS 60R – 050</b>
20.9	10	8	8-M4	6	3	1.8	12	0	45	20	9.5	0.36	<b>WS 65R – 020</b>
18.9	10	8	8-M4	6	3	1.8	12	8	45	20	13.6	0.38	<b>WS 65R – 030</b>
24	10	8	8-M4	8	3	1.8	12	0	30	33	17.3	0.60	<b>WS 75R – 040</b>
20	10	8	8-M4	8	3	1.8	12	15	30	33	21.1	0.64	<b>WS 75R – 050</b>
26	10	5	8-M5	10	3	1.8	15	0	45	24	21.6	0.61	<b>WS 80R – 010</b>
26	10	5	8-M5	10	3	1.8	15	0	45	24	15.6	0.61	<b>WS 80R – 020</b>
23.5	10	5	8-M5	10	4	2.5	15	8	45	44	22.0	0.65	<b>WS 80R – 030</b>
28.5	10	5	8-M5	10	5	3	20	10	30	58	28.2	0.98	<b>WS 90R – 040</b>
21	10	5	8-M5	10	5	3	20	17	30	58	34.2	1.02	<b>WS 90R – 050</b>

Catalogue number	Allowable output torque for different input revolutions per minute (Unit: N-cm)							
	50rpm	100rpm	500rpm	1,000rpm	1,500rpm	2,000rpm	2,500rpm	3,000rpm
<b>WS 55R – 020</b>	27.8	25.2	18.0	14.7	13.0	11.7	10.8	10.0
<b>WS 55R – 030</b>	59.3	54.2	39.6	32.7	29.7	26.6	24.4	23.0
<b>WS 60R – 040</b>	101.7	92.8	69.4	57.7	51.3	46.9	43.5	41.1
<b>WS 60R – 050</b>	153.0	140.2	106.9	89.3	79.2	72.9	67.7	63.9
<b>WS 65R – 020</b>	84.5	75.9	53.4	44.5	37.8	35.0	32.4	30.6
<b>WS 65R – 030</b>	179.3	164.2	119.5	98.2	86.8	79.3	73.6	69.2
<b>WS 75R – 040</b>	306.0	281.4	207.0	172.6	153.6	139.0	129.9	122.4
<b>WS 75R – 050</b>	465.2	424.5	319.5	266.4	238.4	217.8	202.2	192.5
<b>WS 80R – 010</b>	191.7	171.1	112.8	90.5	77.5	69.3	63.0	58.4
<b>WS 80R – 020</b>	192.4	174.6	120.5	98.2	85.7	78.2	72.0	67.1
<b>WS 80R – 030</b>	409.1	374.0	265.7	218.2	191.7	175.2	162.8	152.8
<b>WS 90R – 040</b>	697.4	638.0	463.9	382.7	337.5	309.6	288.2	271.1
<b>WS 90R – 050</b>	1,056.7	968.1	713.2	591.9	522.9	479.7	447.4	421.7

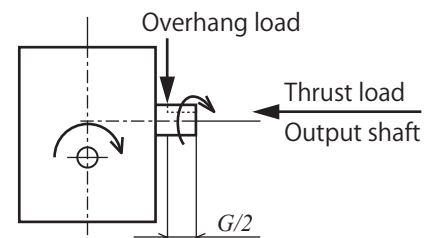

Fig. Overhang load position, thrust load, and shaft rotational direction

# Memo

CONTENTS

INFORMATION

**GEARBOXES**

ANTI-BACKLASH  
SPUR GEARS

SPUR GEARS

RACKS

HELICAL GEARS AND  
SCREW GEARS

MITTER GEARS

BEVEL GEARS

WORMS AND WORM  
WHEELS

REFERENCES

# Anti-backlash spur gears

## Control-backlash spur gears

### NS series

### NSG series

### ASG series



\* These are samples

## How to Read Catalogue Numbers

**NSG 80 S 80 B + 08 10**

Tooth finishing & Gear type	Module	Material	Number of teeth	Shape	Hole finish	Face width	Hole diameter
ASG : Tooth grinding Control-backlash spur gear NSG : Tooth grinding Anti-backlash spur gear NS : Tooth cutting Anti-backlash spur gear	Represents the module size. When the module is less than 1, it indicates a value 100 times the actual module. Example: Module 0.5 → "50" Module 0.8 → "80"	ASG, NSG series S : SCM435, 440 NS series S : S45C SU : SUS304 AL : A5056	Example: When the number of teeth is 80: "80"	B : Hub provided on one side	[-]: No screw holes provided, no key grooves provided, ASG series: ground finish [+]: One screw hole provided NSG series: ground finish NS series: turning finish	Unit: mm	Unit: mm

**These are products that meets the need to eliminate backlash in line with the development of industries such as mechatronics and precision equipment.**

### Features of our standard Anti-backlash spur gears and Control-backlash spur gears

- 1) Mainly small module size.
- 2) Materials include aluminum, S45C, SCM435, SCM440 and SUS304.  
(Control-backlash spur gear is SCM435 or SCM440.)

Catalogue number	ASG	NSG	NS	NSU	NS
Shape					
Page	P. 56	P. 56	P. 58	P. 58	P. 58
Material	SCM435, 440	SCM435, 440	S45C	SUS304	A5056
Module	m1 to 2	m0.5 to 1	m0.8 to 1	m0.5	m0.5 to 1
Mechanism parts	Fixing bolts	Arc spring / Coil spring	Coil spring	Coil spring	Arc spring
Teeth process sequence	Grinding after Induction hardening	Grinding	Soft nitriding after cutting	Teflon after cutting	White alumite after cutting

# Anti-backlash gear information

## 1. How to Use Control Backlash Gears (ASG Series)

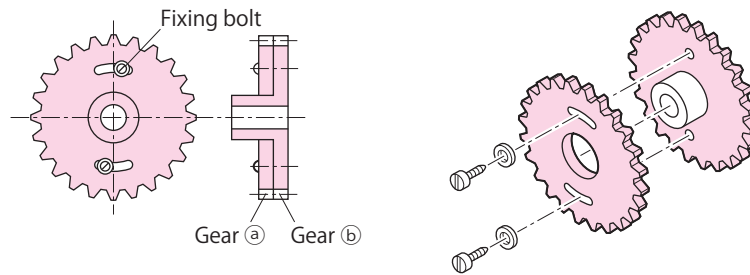

### 1) Principle and assembly method

The control-backlash spur gear consists of gear ①, gear ② and fixing bolts and is a gear mechanism by which the backlash can be adjusted to the minimum value or required value as it meshes with the mating gear. Loosen the fixing bolts and mesh gear ① and gear ② with the mating gear. To adjust the backlash, adjust the phases of gear ① and gear ② so that the target backlash is achieved with the mating gear over the whole circumference. Then, tighten the fixing bolts.

### 2) Ideal mating gears

SG series ground spur gears (The higher precision the mating gear has, the greater the effect the ASG series has.)

### 3) How to set the optimal backlash (Fig. 1)

- ① Loosen the fixing bolts and mesh gear ① and gear ② with the mating gear.
- ② Rotate gear ① and gear ② to adjust the backlash.
- ③ Tighten the fixing bolts to an appropriate torque. (For the tightening torque, refer to the relevant Japanese Industrial Standard (JIS).) Rotate the mating gear and control backlash gear once. If they do not rotate smoothly due to an insufficient backlash, adjust the backlash again.

#### To reduce the intermeshing backlash

The backlash may be reduced by adjusting the intermeshing between the control backlash gear and mating gear.

- ① Loosen the fixing bolts and mesh gear ① and gear ② with the mating gear.
- ② Adjust the phases of gear ① and gear ② to adjust the backlash.
- ③ Tighten the fixing bolts.

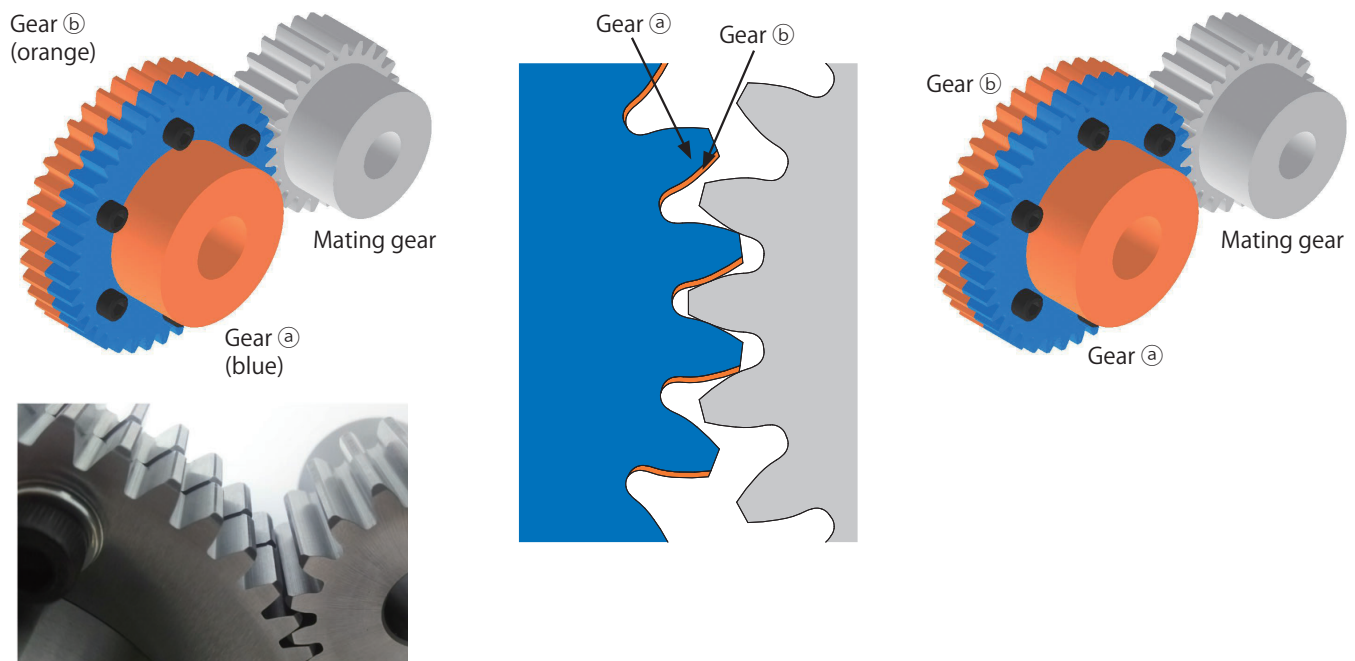

Fig. 1 How to set the optimal backlash

Intermeshing of gears

# Anti-backlash gear information

## 4) Prevention of loose fixing bolts and maintenance

After tightening the fixing bolts, mark them so that loose bolts can be found easily and visually. Check the tightening torque periodically and perform necessary maintenance.

## Cautions

### 1) Prevention of accidents

Tightening the fixing bolts without stopper spring washers or with an insufficient tightening torque may cause the fixing bolts to come off during operation, which is very dangerous. Be sure to check the fixing bolts before operation.

### 2) Why must the allowable transfer torque be observed?

Because the gears are secured with only a few bolts, if the allowable transfer torque is exceeded during operation, the control backlash gear cannot fulfill its function and could induce an accident or failure. Be sure to observe the allowable transfer torque. If there is a need to transmit a larger torque, consult us.

### 3) Backlash for anti-backlash spur gears

The inertia generated by rapid acceleration or deceleration may cause an error.

## 2. How to Use Anti-Backlash Spur Gears (NSG and NS Series)

Type	Spring used	Shape
BS type	Arc spring	
BW type	Coil spring	

### 1) Principle and assembly method

The anti-backlash spur gear consists of gear (a) and (b) and has a mechanism in which gear (a) and gear (b) are meshed with the mating gear to transmit the rotational force by spring force with "zero" backlash. Although the transmitted force is restricted by the spring force, the anti-backlash spur gear is used for low-load devices that require high-precision positioning and devices that rotate in the forward and reverse directions and are adversely affected by a backlash.

### 2) Ideal mating gears

NSG series: SG series and SGR series ground spur gears

NS series: S series spur gears, and RK series racks (Material: S45C, SUS304)

# Anti-backlash gear information

## 3) How to set the transfer torque

### ① Initial state

When the spring installed in the anti-backlash spur gear is in a free state, the teeth of gear Ⓐ and gear Ⓑ are out of phase. (Fig. 1)

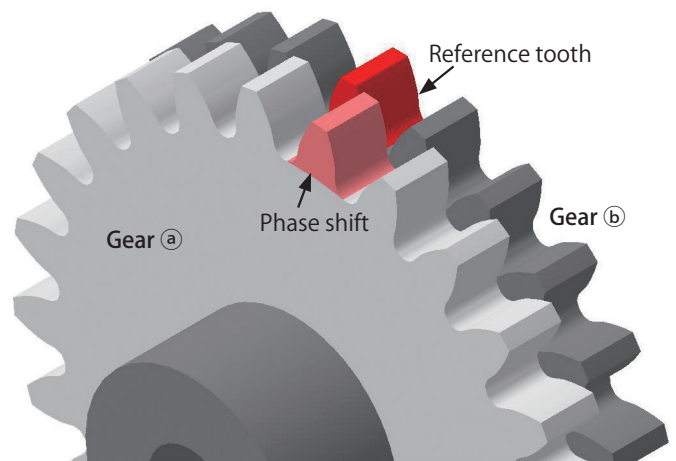

Fig. 1 Initial state

### ② Zero point for tooth positioning (n0)

Considering the point at which the spring extends and the reference teeth of gear Ⓐ and gear Ⓑ align when gear Ⓐ is rotated with gear Ⓑ fixed as the zero point for tooth positioning (n0), use it as the reference position for setting the transfer torque. (Fig. 2)

Rotational direction of gear Ⓐ (tension direction of spring)  
- BS type: Direction of the arrow stamped on the lateral face  
- BW type: Direction that the spring extends

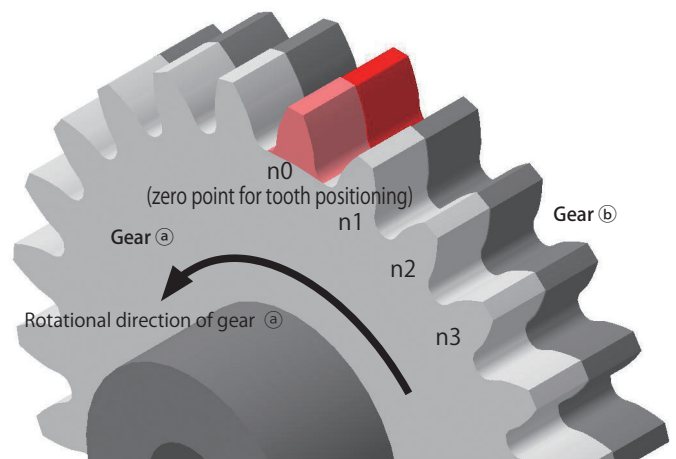

Fig. 2 Zero point for tooth positioning (n0)

### ③ Selection of the pitch shift amount (n1, n2, n3...)

Let the point at which the tooth next to the reference tooth of gear Ⓐ aligns with the reference tooth of gear Ⓑ when gear a is rotated further by pitch shift amount n1 (Fig. 3), and the points at which the subsequent teeth of gear Ⓐ align with the reference tooth of gear Ⓑ be n2, n3, ... The relationship between the pitch shift amount and allowable transfer torque differs from one product to another. Confirm the allowable transfer torque table on the respective pages.

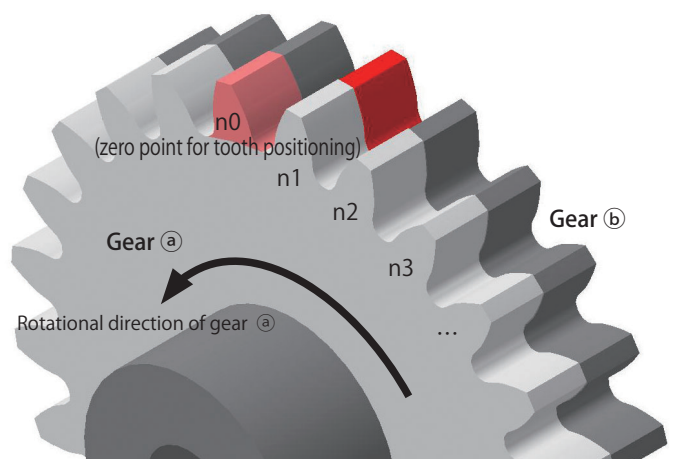

Fig. 3 Pitch shift

## 4) Why must the allowable transfer torque be observed?

The values specified in the allowable transfer torque table must be strictly observed. If the load torque exceeds the allowable transfer torque, backlash is generated.

# Anti-backlash gear information

## 3. Cautions on the Allowable Transfer Torques of Some Anti-Backlash Spur Gears

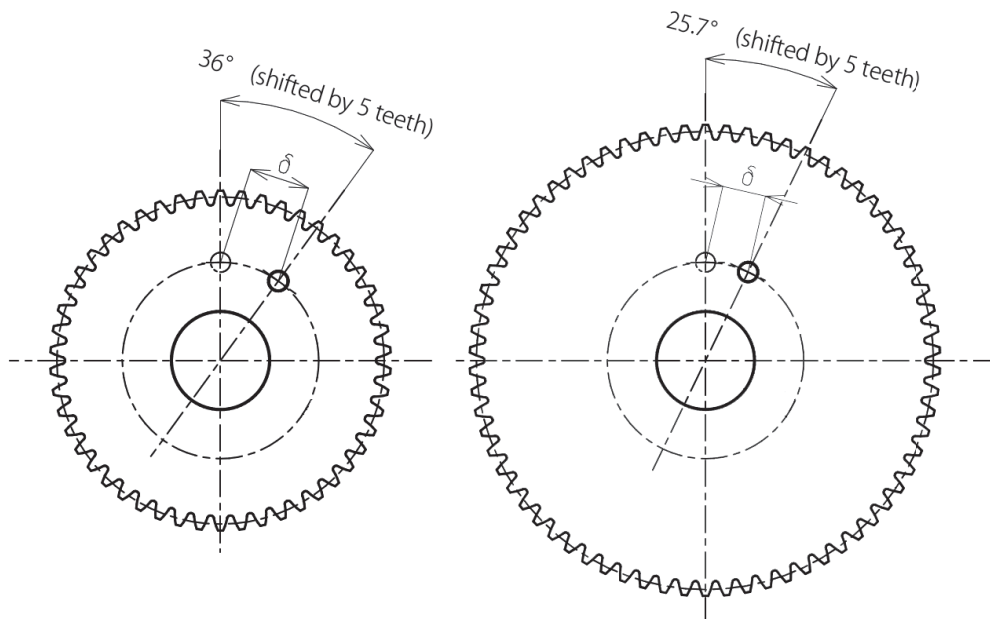

$\delta$  : Elongation of spring (displacement)

(This is not an actual product drawing but is a schematic for some products prepared for explanation.)

Relationship between the number of teeth and allowable torque  
(Anti-backlash spur gears that have the same shift amount with different numbers of teeth.)

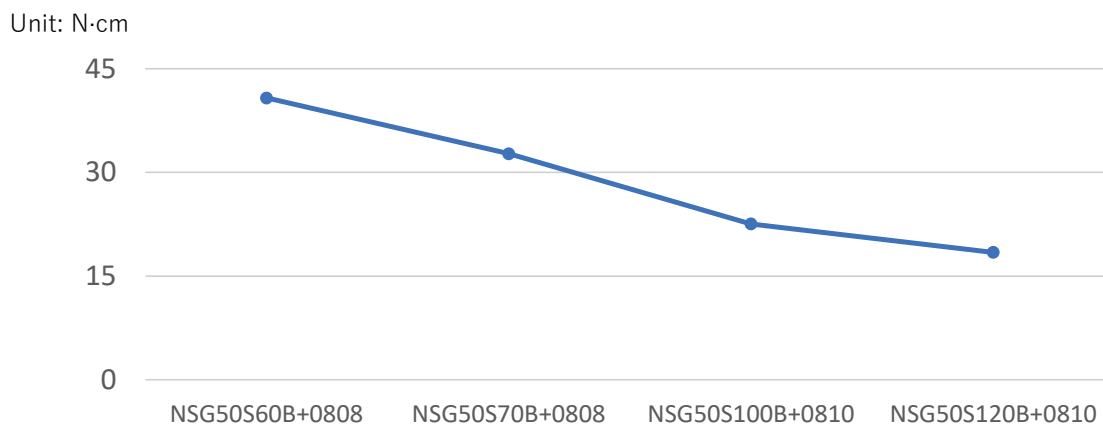

Generally, gears of the same specifications have an allowable transfer torque proportional to the number of teeth. However, some of our anti-backlash spur gears have an allowable transfer torque inversely proportional to the number of teeth for design reasons. The allowable transfer torque of an anti-backlash spur gear is determined by **the specifications of the spring (spring constant, installation location, and quantity)** and **the displacement of the spring ( $\delta$ )**, which depends on the number of teeth by which one gear is rotated with the other gear fixed.

In particular, when anti-backlash spur gears with different numbers of teeth are designed with springs of the same specifications (spring constant, installation location, and quantity), those with a smaller number of teeth have a larger allowable transfer torque. This is because anti-backlash spur gears with a smaller number of teeth have a larger tooth space split angle per tooth and therefore have a larger spring displacement ( $\delta$ ) if one gear is rotated with the other gear fixed by the same number of teeth. Therefore, when selecting a product, be sure to confirm the allowable transfer torque table.

★ Representative example: NSG series and Aluminum (A5056) gears of the NS series





Unit: mm

Accuracy of gears ① and ② before assembly	Material	Pressure angle	Heat treatment	Tooth surface hardness	Tooth surface machining
[JIS B 1702-1] Class N5	SCM435, 440	20°	Induction hardening of teeth	HRC49 to 55	Tooth surface grinding

- ★ No surface treatment is applied.
- ★ Observe the torque specified in the allowable transfer capability table so as to maintain the anti-backlash function.
- ★ For ASG series gears, gear ① and gear ② are secured with bolts after their positions are adjusted in order to control the backlash. \*For the tightening torque, refer to the relevant Japanese Industrial Standard (JIS).

Catalogue number	Module	Number of teeth	Reference diameter	Tip diameter	Face width	Hole diameter	Hub diameter	Hub length	Overall length	Fixing screw	Weight
	<i>m</i>	<i>z</i>	<i>d</i>	<i>d<sub>a</sub></i>	<i>b</i>	<i>d<sub>a</sub>(H7)</i>	<i>d<sub>h</sub></i>	<i>l<sub>h</sub></i>	<i>l</i>		<i>W(kg)</i>
<b>ASG1S 70B — 1012</b>	1	70	φ 70	φ 72	10	φ12	φ40	10	20	6-M4-φ 54	0.39
<b>ASG1.5S 40B — 1515</b>	1.5	40	φ 60	φ 63	15	φ15	φ35	15	30	6-M4-φ 46	0.41
<b>ASG1.5S 50B — 1520</b>		50	φ 75	φ 78		φ20	φ45			6-M5-φ 58	0.64
<b>ASG1.5S 60B — 1520</b>		60	φ 90	φ 93		φ20	φ60			6-M5-φ 74	1.02
<b>ASG2S 30B — 2015</b>	2	30	φ 60	φ 64	20	φ15	φ35	20	40	6-M4-φ 45	0.54
<b>ASG2S 40B — 2020</b>		40	φ 80	φ 84		φ20	φ50			6-M5-φ 62	1.01
<b>ASG2S 50B — 2020</b>		50	φ100	φ104		φ20	φ60			6-M6-φ 78	1.59

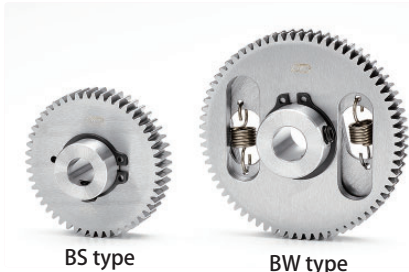

Unit: mm

Accuracy of gears ① and ② before assembly	Material	Pressure angle	Heat treatment	Tooth surface hardness	Tooth surface machining
[JIS B 1702-1] Class N5	SCM435, 440	20°	—	—	Tooth surface grinding

- ★ No surface treatment is applied. Gears with a [+] are provided with screw holes and set screws.
- ★ Observe the torque specified in the allowable transfer capability table so as to maintain the anti-backlash function. This value takes into consideration not only the factors of the gear itself but also the effect of the spring elasticity on the displacement.
- ★ For NSG series gears, a spring is used to mesh gear ① and gear ② with the mating gear, and the backlash is eliminated by the spring force.
- ★ The BS type uses an arc spring and the BW type uses a coil spring.
- ★ \*"n" in the allowable transfer torque table indicates the pitch shift amount. For details, refer to "How to Use Anti-Backlash Spur Gears."

Catalogue number	Module	Number of teeth	Reference diameter	Tip diameter	Type	Number of springs	Face width	Hole diameter	Hub diameter	Hub length	Overall length	Screw		Weight
												<i>M</i>	<i>l<sub>s</sub></i>	
	<i>m</i>	<i>z</i>	<i>d</i>	<i>d<sub>a</sub></i>			<i>b</i>	<i>d<sub>a</sub>(H7)</i>	<i>d<sub>h</sub></i>	<i>l<sub>h</sub></i>	<i>l</i>			
<b>NSG50S 60B + 0808</b>	0.5	60	φ 30	φ 31	BS	1	8	φ 8	φ16	8	16	M4	4	45
<b>NSG50S 70B + 0808</b>		70	φ 35	φ 36				φ 8	φ16					61
<b>NSG50S 100B + 0810</b>		100	φ 50	φ 51				φ10	φ20					128
<b>NSG50S 120B + 0810</b>		120	φ 60	φ 61				φ10	φ20					182
<b>NSG80S 50B + 0810</b>	0.8	50	φ 40	φ 41.6	BW	2	8	φ10	φ20	10	18	M5	5	87
<b>NSG80S 80B + 0810</b>		80	φ 64	φ 65.6				φ10	φ20					200
<b>NSG1S 50B + 1010</b>	1	50	φ 50	φ 52	BS	1	10	φ10	φ20	10	20	M6	5	144
<b>NSG1S 60B + 1010</b>		60	φ 60	φ 62				φ10	φ20					212

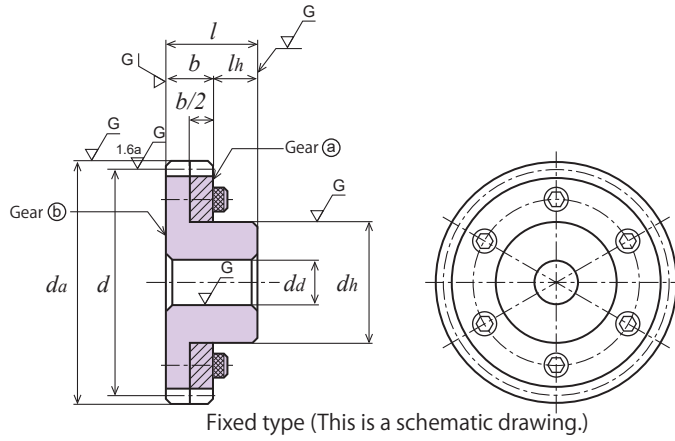

Fixed type (This is a schematic drawing.)

Allowable transfer capability table for different revolutions per minute Bending strength (Unit: kW)							Allowable transfer capability table for different revolutions per minute Surface durability (Unit: kW)							Catalogue number
400 rpm	800 rpm	1,200 rpm	1,500 rpm	1,800 rpm	2,500 rpm	3,000 rpm	400 rpm	800 rpm	1,200 rpm	1,500 rpm	1,800 rpm	2,500 rpm	3,000 rpm	
1.38	2.77	4.01	4.90	5.79	7.66	8.84	0.86	1.77	2.62	3.25	3.87	5.23	6.10	<b>ASG1S 70B – 1012</b>
2.36	4.72	6.95	8.49	10.02	13.45	15.60	0.95	1.93	2.90	3.58	4.26	5.84	6.84	<b>ASG1.5S 40B – 1515</b>
3.12	6.22	8.98	10.99	12.95	17.03	19.60	1.50	3.07	4.52	5.60	6.67	8.95	10.41	<b>ASG1.5S 50B – 1520</b>
3.89	7.64	11.01	13.47	15.76	20.38	23.64	2.19	4.43	6.52	8.08	9.55	12.60	14.77	<b>ASG1.5S 60B – 1520</b>
3.84	7.67	11.29	13.80	16.27	21.85	23.34	1.26	2.58	3.86	4.77	5.69	7.78	9.12	<b>ASG2S 30B – 2015</b>
5.60	11.10	15.99	19.59	23.06	30.11	34.71	2.29	4.66	6.85	8.51	10.12	13.48	15.70	<b>ASG2S 40B – 2020</b>
7.40	14.37	20.72	25.28	29.32	37.96	43.98	3.64	7.29	10.74	13.28	15.57	20.56	24.07	<b>ASG2S 50B – 2020</b>

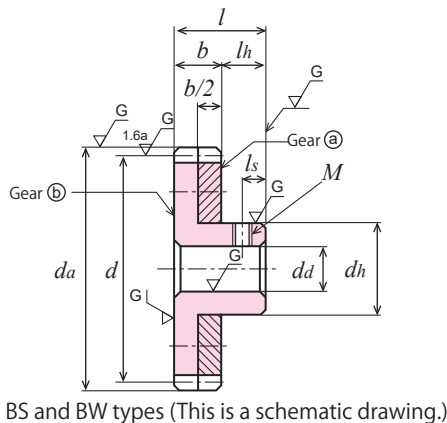

BS and BW types (This is a schematic drawing.)

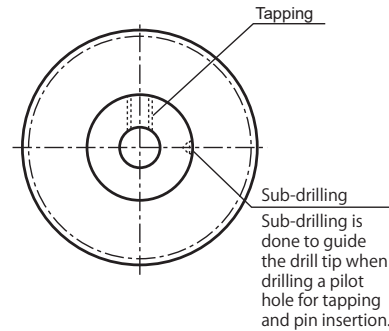

(Except the ASG and NSU series)

Allowable transfer torque table for different shift amounts (Unit: N·cm)				Catalogue number
n2	n3	n4	n5	
13.33	21.18	31.08	40.79	<b>NSG50S 60B + 0808</b>
10.86	16.35	24.83	32.72	<b>NSG50S 70B + 0808</b>
8.16	12.91	17.81	22.55	<b>NSG50S 100B + 0810</b>
7.25	10.39	15.29	18.43	<b>NSG50S 120B + 0810</b>
14.12	25.36	32.68	42.09	<b>NSG80S 50B + 0810</b>
46.44	56.48	66.73	76.98	<b>NSG80S 80B + 0810</b>
18.14	27.29	35.13	47.85	<b>NSG1S 50B + 1010</b>
16.86	23.92	31.77	40.99	<b>NSG1S 60B + 1010</b>

# NS

## Anti-backlash spur (S45C)

Module 0.8/1

(Full Depth Tooth)



Unit: mm

Accuracy of gears (a) and (b) before assembly	Material	Pressure angle	Surface treatment	Tooth surface hardness
[JIS B 1702-1] Class N8	S45C	20°	Soft nitriding	MH v 450 or more

- ★ The allowable transfer capability table shows the torque values that you must observe in order to maintain the anti-backlash function. These values take into consideration not only the factors of the gear itself but also the effect of the spring elasticity on the displacement.
- ★ For NS series gears, a spring is used to mesh gear (a) and gear (b) with the mating gear, and the backlash is eliminated by the spring force.
- ★ The BW type uses a coil spring. Gears with a [+] are provided with screw holes and set screws (made of steel).
- ★ "n" in the allowable transfer torque table indicates the pitch shift amount. For details, refer to "How to Use Anti-Backlash Spur Gears."

Catalogue number	Module <i>m</i>	Number of teeth <i>z</i>	Reference diameter <i>d</i>	Tip diameter <i>d<sub>a</sub></i>	Type	Number of springs	Face width <i>b</i>	Hole diameter <i>d<sub>a</sub>(H7)</i>	Hub diameter <i>d<sub>h</sub></i>	Hub length <i>l<sub>h</sub></i>	Overall length <i>l</i>	Screw		Weight <i>W(g)</i>
												<i>M</i>	<i>l<sub>s</sub></i>	
NS80S 80B + 0810	0.8	80	φ 64	φ 65.6	BW	2	8	φ 10	φ 20	10	18	M5	5	200
NS80S 100B + 0810		100	φ 80	φ 81.6		2		φ 24	324					
NS1S 70B + 1012	1	70	φ 70	φ 72	BW	2	10	φ 12	φ 24	10	20	M6	5	298
NS1S 100B + 1012		100	φ 100	φ 102		3		φ 30	632					
NS1S 120B + 1012		120	φ 120	φ 122		3		φ 30	903					

# NSU

## Anti-backlash spur (SUS304)

Module 0.5

(Full Depth Tooth)



Unit: mm

Accuracy of gears (a) and (b) before assembly	Material	Pressure angle	Surface treatment	Tooth surface hardness
[JIS B 1702-1] Class N9	SUS304	20°	Teflon	—

- ★ This allowable transfer capability table shows the torque values that you must observe in order to maintain the anti-backlash function. These values take into consideration not only the factors of the gear itself but also the effect of the spring elasticity on the displacement.
- ★ For NSU series gears, a spring is used to mesh gear (a) and gear (b) with the mating gear, and the backlash is eliminated by the spring force.
- ★ The BW type uses a coil spring. Gears with a [+] are provided with screw holes and set screws (made of steel).
- ★ "n" in the allowable transfer torque table indicates the pitch shift amount. For details, refer to "How to Use Anti-Backlash Spur Gears."
- ★ Teflon surface treatment is applied to prevent galling and ensure smooth sliding.

Catalogue number	Module <i>m</i>	Number of teeth <i>z</i>	Reference diameter <i>d</i>	Tip diameter <i>d<sub>a</sub></i>	Type	Number of springs	Face width <i>b</i>	Hole diameter <i>d<sub>a</sub>(H8)</i>	Hub diameter <i>d<sub>h</sub></i>	Hub length <i>l<sub>h</sub></i>	Overall length <i>l</i>	Screw		Weight <i>W(g)</i>	
												<i>M</i>	<i>l<sub>s</sub></i>		
NS50SU 60B + 0505	0.5	60	φ 30	φ 31	BW	2	5	φ 5	φ 12	8	13	M3	4	32.3	
NS50SU 70B + 0508		70	φ 35	φ 36		2		φ 8	φ 16					M3	45.7
NS50SU 80B + 0508		80	φ 40	φ 41		3		φ 8	φ 16					M3	57.4
NS50SU 90B + 0510		90	φ 45	φ 46		3		φ 10	φ 20					M4	74.9
NS50SU 100B + 0510		100	φ 50	φ 51		3		φ 10	φ 20					M4	89.7
NS50SU 120B + 0510		120	φ 60	φ 61		4		φ 10	φ 20					M4	123.9

# NS

## Anti-backlash spur (A5056)

Module 0.5/0.8/1

(Full Depth Tooth)



Unit: mm

Accuracy of gears (a) and (b) before assembly	Material	Pressure angle	Surface treatment	Tooth surface hardness
[JIS B 1702-1] Class N9	A5056	20°	White alumite	—

- ★ This allowable transfer capability table shows the torque values that you must observe in order to maintain the anti-backlash function. These values take into consideration not only the factors of the gear itself but also the effect of the spring elasticity on the displacement.
- ★ For NS series gears, a spring is used to mesh gear (a) and gear (b) with the mating gear, and the backlash is eliminated by the spring force.
- ★ The BS type uses an arc spring. Gears with a [+] are provided with screw holes and set screws (made of steel).
- ★ "n" in the allowable transfer torque table indicates the pitch shift amount. For details, refer to "How to Use Anti-Backlash Spur Gears."

Catalogue number	Module <i>m</i>	Number of teeth <i>z</i>	Reference diameter <i>d</i>	Tip diameter <i>d<sub>a</sub></i>	Type	Number of springs	Face width <i>b</i>	Hole diameter <i>d<sub>a</sub>(H8)</i>	Hub diameter <i>d<sub>h</sub></i>	Hub length <i>l<sub>h</sub></i>	Overall length <i>l</i>	Screw		Weight <i>W(g)</i>	
												<i>M</i>	<i>l<sub>s</sub></i>		
NS50AL 60B + 0808	0.5	60	φ 30	φ 31	BS	1	8	φ 8	φ 16	8	16	M4	4	16	
NS50AL 70B + 0808		70	φ 35	φ 36				φ 8	φ 16					21	
NS50AL 80B + 0808		80	φ 40	φ 41				φ 8	φ 20					30	
NS50AL 90B + 0810		90	φ 45	φ 46				φ 10	φ 20					36	
NS50AL 100B + 0810		100	φ 50	φ 51				φ 10	φ 20					44	
NS80AL 50B + 0810	0.8	50	φ 40	φ 41.6	BS	1	8	φ 10	φ 20	10	18	M5	5	30	
NS1AL 50B + 1010	1	50	φ 50	φ 52			10	φ 10	φ 20	φ 20	10	20	M6	5	49
NS1AL 60B + 1010		60	φ 60	φ 62											φ 10

# NS

## Anti-backlash spur (S45C)

Module 0.8/1

(Full Depth Tooth)



Allowable transfer torque table for different shift amounts (Unit: N·cm)				Catalogue number
$n_2$	$n_3$	$n_4$	$n_5$	
46.44	56.48	66.73	76.98	<b>NS80S 80B + 0810</b>
47.59	61.19	74.53	87.33	<b>NS80S 100B + 0810</b>
31.35	41.41	-	-	<b>NS1S 70B + 1012</b>
74.19	103.29	122.90	145.78	<b>NS1S 100B + 1012</b>
81.19	109.04	139.63	160.81	<b>NS1S 120B + 1012</b>

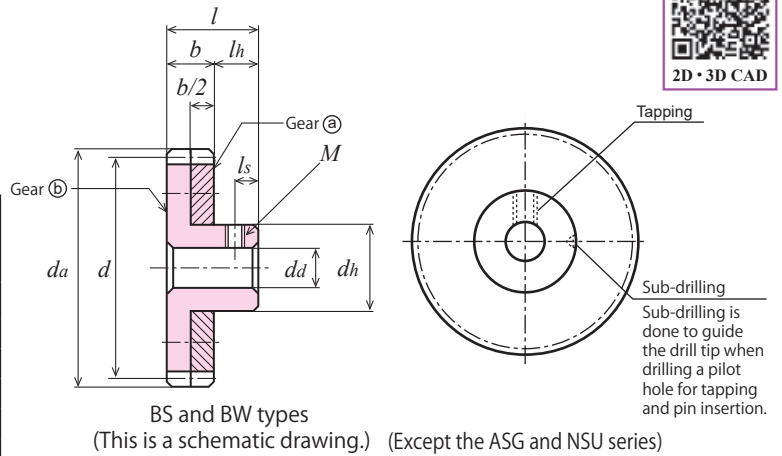

# NSU

## Anti-backlash spur (SUS304)

Module 0.5

(Full Depth Tooth)

Allowable transfer torque table for different shift amounts (Unit: N·cm)		Catalogue number
$n_2$		
9.71		<b>NS50SU 60B + 0505</b>
11.17		<b>NS50SU 70B + 0508</b>
16.18		<b>NS50SU 80B + 0508</b>
19.49		<b>NS50SU 90B + 0510</b>
30.69		<b>NS50SU 100B + 0510</b>
39.85		<b>NS50SU 120B + 0510</b>

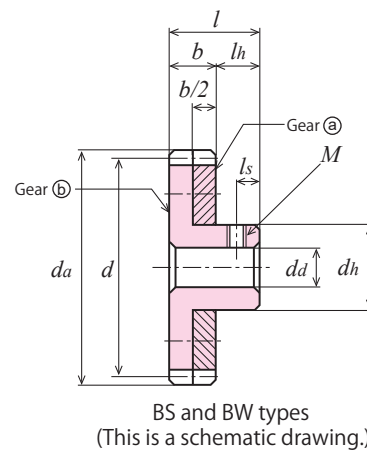

# NS

## Anti-backlash spur (A5056)

Module 0.5/0.8/1

(Full Depth Tooth)

Allowable transfer torque table for different shift amounts (Unit: N·cm)				Catalogue number
$n_2$	$n_3$	$n_4$	$n_5$	
13.33	21.18	31.08	40.79	<b>NS50AL 60B + 0808</b>
10.86	16.35	24.83	32.72	<b>NS50AL 70B + 0808</b>
11.50	16.47	20.79	26.93	<b>NS50AL 80B + 0808</b>
10.00	14.41	19.12	23.68	<b>NS50AL 90B + 0810</b>
8.16	12.91	17.81	22.55	<b>NS50AL 100B + 0810</b>
14.12	25.36	32.68	42.09	<b>NS80AL 50B + 0810</b>
18.14	27.29	35.13	47.85	<b>NS1AL 50B + 1010</b>
16.86	23.92	31.77	40.99	<b>NS1AL 60B + 1010</b>

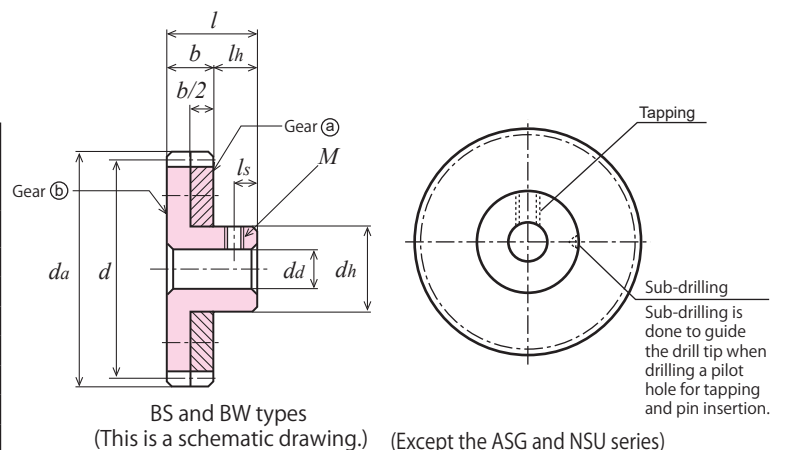

CONTENTS

INFORMATION

GEARBOXES

ANTI-BACKLASH SPUR GEARS

SPUR GEARS

RACKS

HELICAL GEARS AND SCREW GEARS

MITER GEARS

BEVEL GEARS

WORMS AND WORM WHEELS

REFERENCES

CONTENTS

INFORMATION

GEARBOXES

**ANTI-BACKLASH  
SPUR GEARS**

SPUR GEARS

RACKS

HELICAL GEARS AND  
SCREW GEARS

MITTER GEARS

BEVEL GEARS

WORMS AND WORM  
WHEELS

REFERENCES

# Ground spur gears

## Spur gears

SG series  
SGR series  
S series

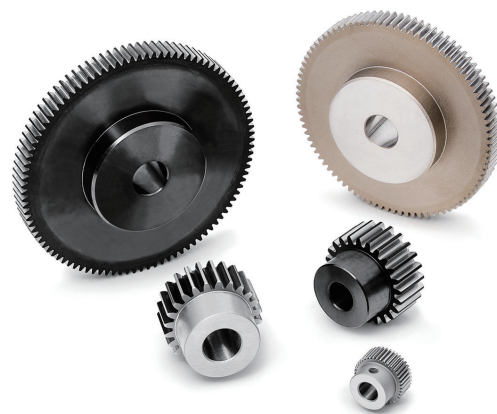

\* These are samples.

### How to Read Catalogue Numbers

**SG 50 S 50 B – 05 06 N**

Gear type	Module	Material	Number of teeth	Shape	Hole finish	Face width	Hole diameter	Type
SG : Ground spur gear (Accuracy grade: JIS Class N5) SGR : Ground spur gear (Accuracy grade: JIS Class N6)	Represents the module size. When the module is less than 1, it indicates a value 100 times the actual module. Example: Module 0.5 → "50" Module 0.8 → "80"	SG Series S: SCM435, 440 SGR Series S: S45C	Example: When the number of teeth is 50: "50"	L: Both side shaft are ground B: Hub provided on one side	SG Series [-]: No screw holes provided, no key grooves provided, ground finish [*]: Two screw holes provided, ground finish SGR Series [-]: No screw hole provided, no key grooves provided, lathe turned finish	Unit: mm	Unit: mm	N: SG Series: Same shape and size as the SGR Series

**S 1 S 25 A – 08 06 F**

Gear type	Module	Material	Number of teeth	Shape	Hole finish	Face width	Hole diameter	Type
S: Spur gear	Represents the module size. When the module is less than 1, it indicates a value 100 times the actual module. Example: Module 0.5 → "50" Module 0.8 → "80"	S : Carbon steel S45C B : Brass C3604B, C3713P SU : Stainless steel SUS304 BP : Acetal Blue POM D : Acetal White POM DB : Acetal White POM Brass C3604 bushing	Example: When the number of teeth is 25: "25"	A : No hub provided B : Hub provided on one side BF: Hub provided on one side (Product for additional machining) L : Shafts provided on both sides K : Cantilever gear	Lathe turning [-]: No screw holes provided, no key grooves provided (except K1 and L1) [+]: One screw hole provided [*]: Two screw holes provided [=]: Key groove provided [#]: One key groove and one screw hole provided	Unit: mm	Unit: mm	F, N: Products for additional machining

**"Use-friendly precision gears" that can be used in the field of mechatronics, including semiconductor production equipment, and for precision equipment and machine tools that require precise movements**

Catalogue number	SG	SGR	S	S	S
Shape					
Page	P. 66	P. 82	P. 94	P. 136	P. 146
Material	SCM435, 440	S45C	S45C	SUS304	Brass
Module	m0.5 to 3	m0.5 to 3	m0.5 to 3	m0.5 to 2	m 0.3 to 0.8
Accuracy grade	JIS Class N5	JIS Class N6	JIS Class N8	JIS Class N9	JIS Class N9/ Outside of control range
Tooth treatment	Grinding after Induction hardening	Grinding after Induction hardening	Cutting	Cutting	Cutting

Catalogue number	S	S	S	S
Shape				
Page	P. 158	P. 160	P. 170	P. 176
Material	White POM (w/ brass bushing)	Blue POM	White POM	White POM (w/ screw hole)
Module	m 1	m0.5 to 3	m0.5 to 1	m0.5 to 1
Accuracy grade	JIS Class N9 to 10 *	JIS Class N9 to 10 *	JIS Class N9 to 10 *	JIS Class N9 to 10 *
Tooth treatment	Cutting	Cutting	Cutting	Cutting

\* Accuracy at the time of manufacture.

# Ground spur gear and Spur gear information

## 1. Features of SG Series and SGR Series Ground Spur Gears

	Accuracy grade JIS B 1702-1	Ground sections	Module	Material	Heat treatment	Hardness	Surface treatment
SG Series	Class N5	See Fig. 1.	0.5 to 3.0	SCM435, 440	Induction hardening of teeth	HRC49 to 55	—
SGR Series	Class N6	See Fig. 2.		S45C *1		HRC50 to 56	Black oxide finish *2

\*1 S45C contains free-cutting material. \*2 No black oxide finish is applied to the tooth surfaces (ground surfaces).

The SG Series is a group of high-precision ground spur gears. The SGR series is an economy type for which only the tooth surfaces are ground.

SG series products whose catalogue number ends in N have enhanced gear performance with higher precision and strength than conventional SGR series products.

SG series products have the same gear dimensions and shape as SGR series products and can be replaced with SGR series products. The products of both series have been treated by induction hardening, and therefore, holes and hubs can be machined.

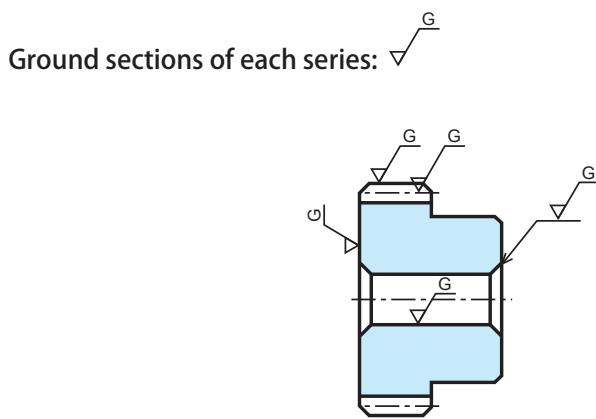

Fig. 1 SG Series

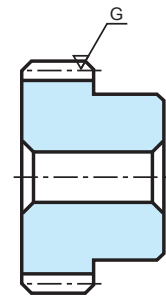

Fig. 2 SGR Series (Economy type)

## 2. Cautions on Machining SG Series and SGR Series Ground Spur Gears

We are always striving to offer high-precision, high-quality ground spur gears. However, machining may deteriorate the precision of the gears. If machining is required, keep the following points in mind.

Also, refer to "Precautions for additional processing" in the KG-General Catalogue.

### 1) When machining holes (hole diameter) of SG or SGR ground spur gears

- ① Be sure to hold the outer circumference of the gear (tooth tips) with a soft jaw and scroll chuck and center the hole surface of the gear. The outer circumference and lateral faces have been finished by grinding. Centering is easy by holding the gear as shown in the figure.
- ② Only the tooth surfaces have been treated by hardening, but for small gears with a small module and a small number of teeth, the hardened layer may reach the bottom of the hole, resulting in poor machinability.
- ③ When machining gears, the maximum drilling diameter should be 60 to 70% of the hub diameter.

### 2) When machining other sections of SG or SGR ground spur gears

- ① Hold the gear in the same manner as when machining holes. When holding the hub with a chuck, be sure to center the hole surface as well.
- ② For gears having shafts on both sides (L type), note that the areas near the teeth (including the shafts) have been hardened by heat treatment.

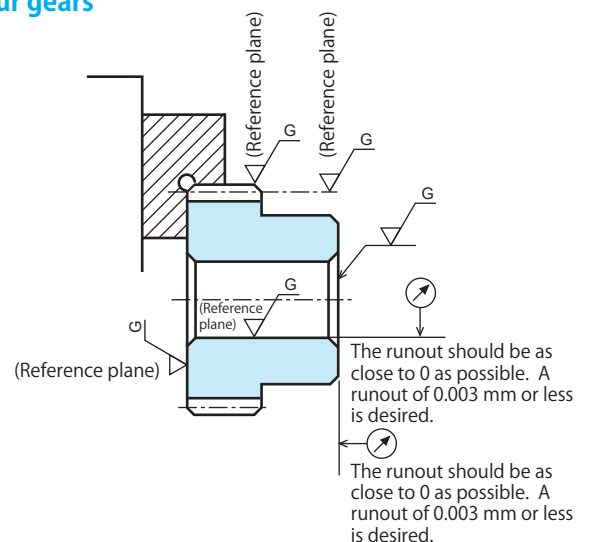

# Ground spur gear and Spur gear information

## 3. Profile-shifted Gears

Profile-shifted gears are gears that have been machined by shifting the tooth cutter slightly from the reference circle in the radial direction. The following description is based on the intermeshing with the reference rack.

Explanation:

RD: Reference Diameter;      IPCD: Intermeshing Pitch Circle Diameter;      TCPCD: Tooth Cutting Pitch Circle Diameter

### 1) Gear with a rack shift coefficient of 0

Positional relationship between the tooth cutter and gear tooth cutting position (See Fig. 1.)

- ① Gear that has a rack shift coefficient ( $x$ ) of 0 when the pitch line of the tooth cutter (reference rack tooth profile) and the RD of the gear align with each other.
- ② RD of profile-shifted gear = TCPCD = IPCD with rack
- ③ Intermeshing center distance =  $\frac{\text{RD of pinion} + \text{RD of gear}}{2}$

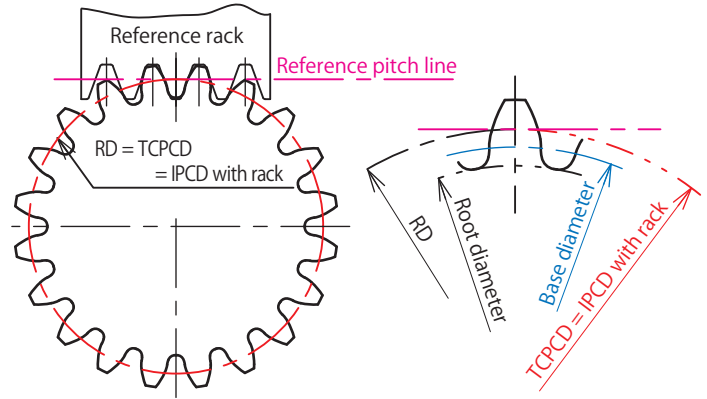

Fig. 1 Tooth profile with a rack shift coefficient ( $x$ ) of 0

### 2) Gear with positive (+) rack shift

Positional relationship between the tooth cutter and gear tooth cutting position (See Fig. 2.)

- ① Gear that has a positive (+) rack shift coefficient ( $x$ ) when the pitch line of the tooth cutter (reference rack tooth profile) is shifted outward from the RD of the gear. Standard spur gears (material: S45C) with modules ( $m$ ) of 1, 1.5, and 2 and 8 to 12 teeth have a positive rack shift coefficient ( $x$ ) of +0.5.
- ② RD of profile-shifted gear < TCPCD = IPCD with rack
- ③ Intermeshing center distance: See "4. Center Distance of Profile-Shifted-Spur Gears" of "Spur Gears - Information."

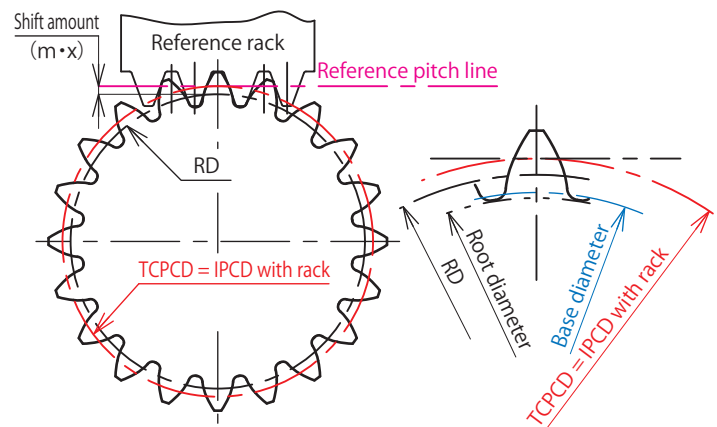

Fig. 2 Tooth profile with a positive (+) rack shift coefficient ( $x$ )

### 3) Gear with negative (-) rack shift

Positional relationship between the tooth cutter and gear tooth cutting position (See Fig. 3.)

- ① Gear that has a negative (-) rack shift coefficient ( $x$ ) when the pitch line of the tooth cutter (reference rack tooth profile) is shifted inward from the RD of the gear.
- ② RD of profile-shifted gear > TCPCD = IPCD with rack

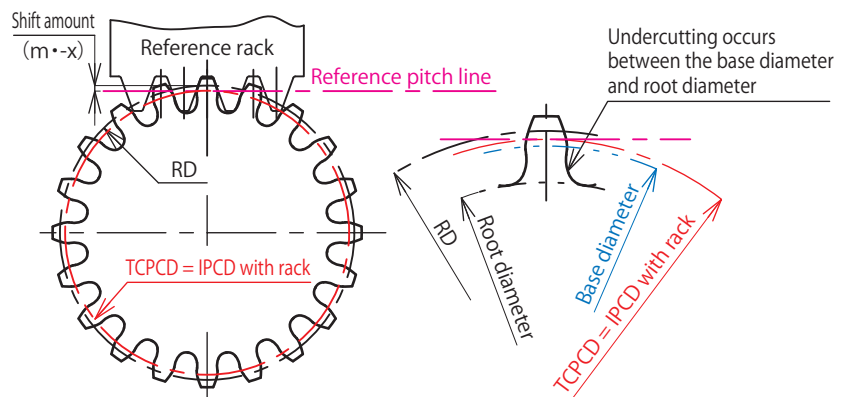

Fig. 3 Tooth profile with a negative (-) rack shift coefficient ( $x$ )

What are profile-shifted gears used mainly for?

- (1) Profile-shifted gears are used to prevent or reduce undercutting. When the root diameter is smaller than the base diameter, profile-shifted gears tend to have smaller tooth root strength (see Fig. 3). This phenomenon appears more remarkably with fewer teeth.
- (2) The contact distance can be adjusted.
- (3) Profile-shifted gears are also used to decrease the gear strength or reduce the meshing noise by adjusting the contact ratio.

What should be noted when using profile-shifted gears?

Complicated calculations are required to obtain the intermeshing center distance of a profile-shifted gear. When using our standard profile-shifted gears, see the table titled [Center Distance of Profile-Shifted-Spur Gears]. For more information, refer to our technical documents.



# Ground spur gear and Spur gear information

CONTENTS

INFORMATION

GEARBOXES

ANTI-BACKLASH  
SPUR GEARS

SPUR GEARS

RACKS

HELICAL GEARS AND  
SCREW GEARS

MITER GEARS

BEVEL GEARS

WORMS AND WORM  
WHEELS

REFERENCES

## “05 Tooth profile” specified by the DIN standard

Our standard spur gears (material: S45C) with 8 to 11 teeth adopt the “05 Tooth profile” specified by the DIN standard.

“05 Tooth profile” means that the rack shift coefficient is fixed at +0.5. With a “05 Tooth profile,” in general, the bottom clearance is smaller, and therefore, the outside diameter is decreased by the product of the addendum reduction coefficient and module ( $k \cdot m$ ).

The following describes how to calculate the rack shift of our standard spur gears (with 8 to 11 teeth).

Contact pressure angle  $\alpha_w$  is expressed as follows:

$$\text{inv } \alpha_w = 2 \tan \alpha \left( \frac{x_1 + x_2}{z_1 + z_2} \right) + \text{inv } \alpha$$

Explanation

$z_1$  = Number of teeth of pinion

$z_2$  = Number of teeth of gear

$x_1$  = Rack shift coefficient of pinion

$x_2$  = Rack shift coefficient of gear

$\alpha_w$  = Pressure angle (tool pressure angle)

inv = Involute function  $\text{inv } \alpha = \tan \alpha - \alpha$

(For the involute function table, refer to P. 164 to 167 in “Technical Data.”)

Center distance modification coefficient  $y$  is expressed as follows:

$$y = \frac{z_1 + z_2}{2} \left( \frac{\cos \alpha}{\cos \alpha_w} - 1 \right)$$

The center distance  $a_s$  is expressed as follows:

$$a_s = \left( \frac{z_1 + z_2}{2} + y \right) m$$

Explanation

$m$  = Module

Intermeshing pitch circle diameters  $d'_1$  and  $d'_2$  are expressed respectively as follows:

$$d'_1 = 2 a_s \left( \frac{z_1}{z_1 + z_2} \right)$$

$$d'_2 = 2 a_s \left( \frac{z_2}{z_1 + z_2} \right)$$

Reference circle diameters  $d_1$  and  $d_2$  are also expressed respectively as follows:

$$d_1 = z_1 m$$

$$d_2 = z_2 m$$

Accordingly, the tip (outside) diameter  $d_{ax}$  is as follows:

$$d_{ax} = 2m \left( \frac{z+3}{2} - k \right)$$

Explanation

$k$  = Addendum reduction coefficient

The following equation results:

$$km = \left[ x_1 + x_2 - \frac{z_1 + z_2}{2} \left( \frac{\cos \alpha}{\cos \alpha_w} - 1 \right) \right] m$$

When the addendum of the tool is  $1.25m$ , the bottom clearance (minimum value) is  $0.21m$ .

When tooth 8 and tooth 8 mesh with each other, the center distance is as follows:

(Rack shift coefficient  $x = 0.5$ )

$$a_s / m = 8.7788 \text{ mm}$$

When tooth 10 and tooth 10 mesh with each other, the center distance is as follows:

(Rack shift coefficient  $x = 0.5$ )

$$a_s / m = 10.8043 \text{ mm}$$

The above calculation example shows the case where the module is 1 mm. For example, when the module is 2 mm and tooth 8 and tooth 8 mesh with each other, since  $a_s/m = 8.7788$  mm, center distance  $a_s$  is as follows:

$$a_s = 8.7788 \times 2$$

$$= 17.5576 \text{ mm}$$

Other standard gears can be used as the mating gear.

Excerpt from the Journal of JGMA (Japan Gear Manufacturers Association) Vol. 54, “German Gear Standards” (DIN 3994 and 3995)

# Ground spur gear and Spur gear information

## 4. Center Distance of Profile-Shifted Spur Gears

Center distance of a spur gear to be meshed with a profile-shifted gear (our standard product)

Recommended center distance in intermeshing with our profile-shifted gear (Unit: mm)

In the table below: The values in the table below indicate the center distance  $a_x$  between gears when the module is 1.

When the gear module changes, multiply the module by the value shown below.

Example: When the module is 2 and the number of teeth is 8, the center distance is  $8.779 \times 2$  (module).

(Currently, the rack shift coefficient  $x$  of our profile-shifted spur gear with module 1 or more is 0.5.)

Number of teeth	8 (profile-shifted)	9 (profile-shifted)	10 (profile-shifted)	11 (profile-shifted)
8 (profile-shifted)	8.779	9.286	9.792	10.298
9 (profile-shifted)	9.286	9.792	10.299	10.804
10 (profile-shifted)	9.792	10.299	10.804	11.310
11 (profile-shifted)	10.299	10.804	11.310	11.815
12	10.437	10.939	11.441	11.943
13	10.939	11.441	11.943	12.445
14	11.441	11.942	12.445	12.946
15	11.943	12.445	12.946	13.448
16	12.445	12.946	13.448	13.949
17	12.946	13.448	13.949	14.451
18	13.448	13.949	14.451	14.952
19	13.949	14.451	14.952	15.453
20	14.451	14.952	15.453	15.954
21	14.952	15.453	15.954	16.455
22	15.453	15.954	16.455	16.956
23	15.954	16.455	16.956	17.457
24	16.455	16.956	17.457	17.958
25	16.956	17.457	17.958	18.459
26	17.457	17.958	18.459	18.960
27	17.958	18.459	18.960	19.461
28	18.459	18.960	19.461	19.962
29	18.960	19.461	19.962	20.463
30	19.461	19.962	20.463	20.963
32	20.463	20.963	21.464	21.965
34	21.464	21.965	22.465	22.966
35	21.965	22.465	22.966	23.467
36	22.465	22.966	23.467	23.967
38	23.467	23.967	24.468	24.968
40	24.468	24.968	25.469	25.969
42	25.469	25.969	26.470	26.970
44	26.470	26.970	27.471	27.971

Number of teeth	8 (profile-shifted)	9 (profile-shifted)	10 (profile-shifted)	11 (profile-shifted)
45	26.970	27.471	27.971	28.472
46	27.471	27.971	28.472	28.972
48	28.472	28.972	29.473	29.973
50	29.473	29.973	30.473	30.974
52	30.473	30.974	31.474	31.974
54	31.474	31.974	32.475	32.975
55	31.974	32.475	32.975	33.475
56	32.475	32.975	33.475	33.976
58	33.475	33.976	34.476	34.976
60	34.476	34.976	35.477	35.977
62	35.477	35.977	36.477	36.977
64	36.477	36.977	37.478	37.978
65	36.977	37.478	37.978	38.478
66	37.478	37.978	38.478	38.979
68	38.478	38.979	39.479	39.979
70	39.479	39.979	40.479	40.979
72	40.479	40.979	41.480	41.980
75	41.980	42.480	42.980	43.480
80	44.481	44.981	45.481	45.981
84	46.482	46.982	47.482	47.982
85	46.982	47.482	47.982	48.482
90	49.483	49.983	50.483	50.983
95	51.983	52.483	52.984	53.484
96	52.483	52.984	53.484	53.984
100	54.484	54.984	55.484	55.985
105	56.985	57.485	57.985	58.485
108	58.485	58.985	59.485	59.985
110	59.485	59.985	60.485	60.986
112	60.485	60.986	61.486	61.986
115	61.986	62.486	62.986	63.486
120	64.486	64.987	65.487	65.987

Assembly distance of a rack to be meshed with our profile-shifted spur gear

$$a = h'' + \frac{m \times z}{2} + xm$$

$a$  : Assembly distance (from the rack bottom to the spur gear center)

$h''$  : Rack datum line (See the production description pages for racks.)

$m$  : Module

$x$  : Rack shift coefficient

$z$  : Number of teeth

When the module is 1 or more and the number of teeth is 8 to 11:

$$x = 0.5$$

When the module is 1 or more and the number of teeth is 12 or more:

$$x = 0$$

\* This is for our standard products.

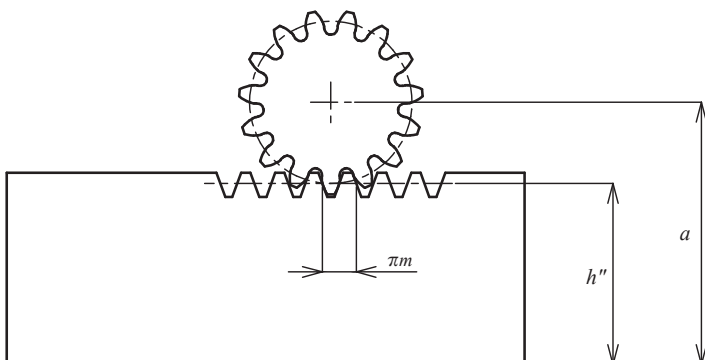

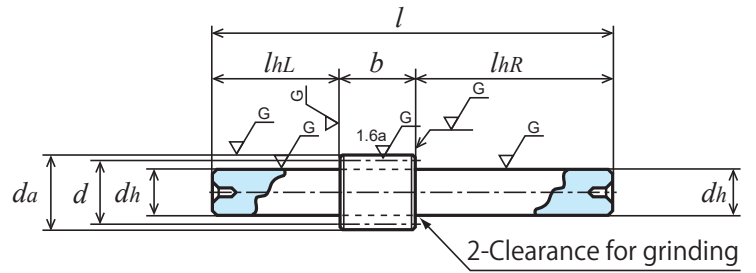
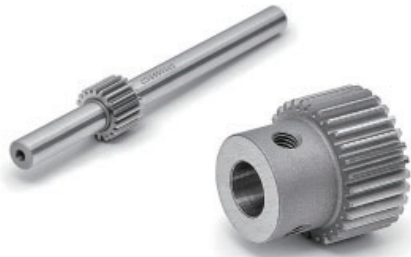

L1 type

Unit: mm

Accuracy Class	Material	Pressure angle	Heat treatment	Tooth surface hardness	Backlash ①
[JIS B 1702-1] N5	SCM435/440	20°	Induction hardening of teeth	HRC49 to 55	See the table below

★ No surface treatment is applied. [\*] Two screw holes and set screws are provided.

★ This allowable transfer capability table was prepared by using the formulas presented by the JGMA (Japan Gear Manufacturers Association). For the unit conversion method, refer to P. 20 in "References."

★ Products with module 0.5 have face widths of 5 mm and 8 mm.

① This is a theoretical value obtained when a pair of gears of the same type and material are meshed with each other.

Catalogue number	Module <i>m</i>	Number of teeth <i>z</i>	Reference diameter <i>d</i>	Tip diameter <i>da</i>	Type	Face width <i>b</i>	Hole diameter <i>da</i> (H7)	Hub diameter <i>dh</i>	Hub length <i>lh</i>	Overall length <i>l</i>	Screw		Weight <i>W</i> (kg)
											<i>M</i>	<i>ls</i>	
SG50S 20L – 0806	0.5	20	φ10	φ11	L1	8	-	φ 6 (h7)	L22 R50	80	-	-	0.021
SG50S 28B – 0805		28	φ14	φ15	B1	8	φ 5	φ10	8	16	-	-	0.012
SG50S 30B – 0505N		30	φ15	φ16		5	φ 5	φ12		13	-	-	0.012
SG50S 30B * 0806		30	φ15	φ16		8	φ 6	φ12		16	2-M3	4	0.014
SG50S 36B – 0808		36	φ18	φ19		8	φ 8	φ16		16	-	-	0.022
SG50S 40B – 0506N		40	φ20	φ21		5	φ 6	φ15		13	-	-	0.021
SG50S 40B – 0806		40	φ20	φ21		8	φ 6	φ16		16	-	-	0.029
SG50S 40B * 0808		40	φ20	φ21		8	φ 8	φ16		16	2-M4	4	0.026
SG50S 50B – 0506N		50	φ25	φ26		5	φ 6	φ18		13	-	-	0.032
SG50S 60B – 0506N		60	φ30	φ31		5	φ 6	φ22		13	-	-	0.049
SG50S 70B – 0508N		70	φ35	φ36		5	φ 8	φ25		13	-	-	0.063
SG50S 72B – 0808		72	φ36	φ37		8	φ 8	φ25		16	-	-	0.088
SG50S 80B – 0508N		80	φ40	φ41		5	φ 8	φ28		13	-	-	0.083
SG50S 90B – 0508N		90	φ45	φ46		5	φ 8	φ32		13	-	-	0.108
SG50S 100B – 0510N	100	φ50	φ51	5		φ10	φ35	13		-	-	0.130	
SG50S 120B – 0510N	120	φ60	φ61	5	φ10	φ42	13	-	-	0.190			
SG80S 15L – 0806	0.8	15	φ12	φ13.6	L1	-	-	φ 6 (h7)	L22 R60	90	-	-	0.025
SG80S 25B – 0806		25	φ20	φ21.6	B1	8	φ 6	φ16	10	18	-	-	0.031
SG80S 25B – 0805N		25	φ20	φ21.6			φ 5	φ16			-	-	0.033
SG80S 30B – 0805N		30	φ24	φ25.6			φ 5	φ20			-	-	0.050
SG80S 40B – 0810		40	φ32	φ33.6			φ10	φ25			-	-	0.077
SG80S 40B – 0808N		40	φ32	φ33.6			φ 8	φ25			-	-	0.082
SG80S 45B – 0810		45	φ36	φ37.6			φ10	φ25			-	-	0.091
SG80S 50B – 0808N		50	φ40	φ41.6			φ 8	φ28			-	-	0.120
SG80S 56B – 0810		56	φ44.8	φ46.4			φ10	φ25			-	-	0.126
SG80S 60B – 0808N		60	φ48	φ49.6			φ 8	φ28			-	-	0.155
SG80S 70B – 0808N		70	φ56	φ57.6			φ 8	φ28			-	-	0.196
SG80S 80B – 0812		80	φ64	φ65.6			φ12	φ30			-	-	0.240
SG80S 80B – 0808N		80	φ64	φ65.6			φ 8	φ28			-	-	0.243
SG80S 90B – 0810N		90	φ72	φ73.6			φ10	φ30			-	-	0.300
SG80S 100B – 0812N	100	φ80	φ81.6	φ12			φ40	-			-	0.398	
SG80S 120B – 0812N	120	φ96	φ97.6	φ12	φ40	-	-	0.534					

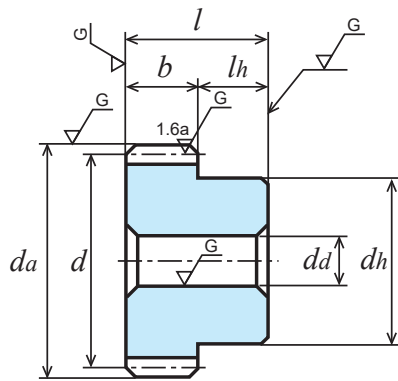

B1 type [-]

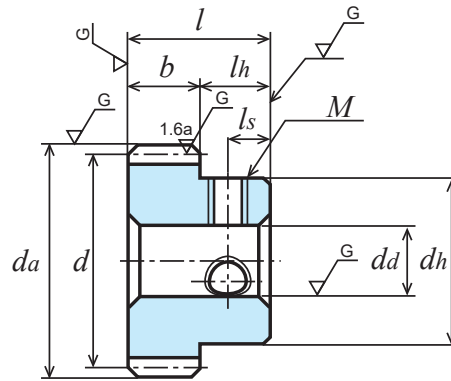

B1 type [\*]

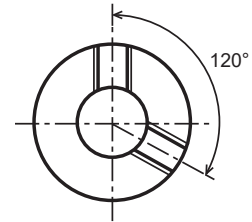

Allowable transfer capability table for different revolutions per minute, Bending strength, (Unit: kW)							Allowable transfer capability table for different revolutions per minute, Surface durability, (Unit: kW)							Backlash (Unit: mm)	Catalogue number
400 rpm	800 rpm	1,200 rpm	1,500 rpm	1,800 rpm	2,500 rpm	3,000 rpm	400 rpm	800 rpm	1,200 rpm	1,500 rpm	1,800 rpm	2,500 rpm	3,000 rpm		
0.10	0.21	0.32	0.40	0.48	0.67	0.81	0.025	0.050	0.076	0.095	0.115	0.161	0.194	0.02 to 0.06	<b>SG50S 20L – 0806</b>
0.17	0.34	0.52	0.65	0.78	1.09	1.31	0.050	0.101	0.152	0.191	0.231	0.324	0.391		<b>SG50S 28B – 0805</b>
0.11	0.23	0.35	0.44	0.53	0.74	0.89	0.036	0.072	0.110	0.138	0.166	0.233	0.282		<b>SG50S 30B – 0505N</b>
0.19	0.38	0.57	0.71	0.86	1.19	1.43	0.057	0.116	0.176	0.221	0.266	0.374	0.451		<b>SG50S 30B * 0806</b>
0.24	0.48	0.73	0.91	1.09	1.52	1.83	0.084	0.169	0.256	0.322	0.389	0.546	0.661		<b>SG50S 36B – 0808</b>
0.17	0.34	0.52	0.65	0.78	1.09	1.30	0.065	0.131	0.199	0.250	0.302	0.425	0.513		<b>SG50S 40B – 0506N</b>
0.27	0.55	0.83	1.04	1.25	1.74	2.09	0.10	0.21	0.31	0.40	0.48	0.68	0.82		<b>SG50S 40B – 0806</b>
0.27	0.55	0.83	1.04	1.25	1.74	2.09	0.10	0.21	0.31	0.40	0.48	0.68	0.82		<b>SG50S 40B * 0808</b>
0.23	0.46	0.69	0.86	1.04	1.43	1.69	0.10	0.20	0.31	0.39	0.48	0.67	0.80		<b>SG50S 50B – 0506N</b>
0.28	0.57	0.86	1.08	1.29	1.76	2.07	0.15	0.30	0.46	0.58	0.70	0.97	1.15		<b>SG50S 60B – 0506N</b>
0.34	0.69	1.03	1.29	1.54	2.08	2.45	0.20	0.41	0.63	0.80	0.96	1.32	1.57		<b>SG50S 70B – 0508N</b>
0.57	1.14	1.17	2.14	2.55	3.43	4.04	0.35	0.71	1.08	1.36	1.63	2.23	2.66		<b>SG50S 72B – 0808</b>
0.40	0.80	1.21	1.51	1.78	2.39	2.83	0.27	0.55	0.84	1.06	1.26	1.72	2.05		<b>SG50S 80B – 0508N</b>
0.46	0.92	1.38	1.71	2.01	2.71	3.20	0.34	0.70	1.07	1.34	1.59	2.18	2.60		<b>SG50S 90B – 0508N</b>
0.52	1.04	1.55	1.91	2.25	3.02	3.56	0.43	0.88	1.33	1.65	1.97	2.70	3.21		<b>SG50S 100B – 0510N</b>
0.63	1.27	1.88	2.29	2.71	3.64	4.22	0.63	1.28	1.93	2.38	2.84	3.89	4.56		<b>SG50S 120B – 0510N</b>
0.17	0.35	0.52	0.66	0.79	1.10	1.32	0.036	0.075	0.11	0.13	0.16	0.23	0.28		<b>SG80S 15L – 0806</b>
0.38	0.76	1.14	1.43	1.71	2.38	2.85	0.104	0.211	0.31	0.40	0.48	0.68	0.82		<b>SG80S 25B – 0806</b>
0.38	0.76	1.14	1.43	1.71	2.38	2.85	0.104	0.211	0.31	0.40	0.48	0.68	0.82		<b>SG80S 25B – 0805N</b>
0.49	0.98	1.47	1.84	2.20	3.05	3.61	0.15	0.30	0.46	0.58	0.70	0.99	1.18		<b>SG80S 30B – 0805N</b>
0.71	1.43	2.14	2.68	3.21	4.34	5.10	0.27	0.55	0.84	1.06	1.29	1.76	2.10		<b>SG80S 40B – 0810</b>
0.71	1.43	2.14	2.68	3.21	4.34	5.10	0.27	0.55	0.84	1.06	1.29	1.76	2.10		<b>SG80S 40B – 0808N</b>
0.82	1.65	2.48	3.11	3.69	4.97	5.86	0.35	0.71	1.08	1.36	1.63	2.23	2.66		<b>SG80S 45B – 0810</b>
0.94	1.89	2.84	3.53	4.18	5.61	6.63	0.43	0.88	1.34	1.69	2.02	2.76	3.29		<b>SG80S 50B – 0808N</b>
1.08	2.17	3.29	4.02	4.74	6.38	7.52	0.55	1.12	1.70	2.13	2.53	3.47	4.13		<b>SG80S 56B – 0810</b>
1.18	2.36	3.54	4.34	5.12	6.89	8.11	0.63	1.29	1.97	2.44	2.90	3.98	4.74		<b>SG80S 60B – 0808N</b>
1.42	2.84	4.20	5.14	6.05	8.14	9.50	0.87	1.79	2.69	3.33	3.96	5.43	6.40		<b>SG80S 70B – 0808N</b>
1.66	3.32	4.85	5.92	6.99	9.34	10.80	1.15	2.36	3.52	4.34	5.18	7.06	8.25		<b>SG80S 80B – 0812</b>
1.66	3.32	4.85	5.92	6.99	9.34	10.80	1.15	2.36	3.52	4.34	5.18	7.06	8.25		<b>SG80S 80B – 0808N</b>
1.90	3.79	5.48	6.70	7.90	10.43	12.02	1.47	3.02	4.45	5.51	6.56	8.83	10.29		<b>SG80S 90B – 0810N</b>
2.14	4.23	6.10	7.48	8.80	11.49	13.25	1.83	3.73	5.48	6.80	8.09	10.78	12.56		<b>SG80S 100B – 0812N</b>
2.62	5.11	7.36	8.99	10.47	13.54	15.70	2.68	5.37	7.92	9.80	11.53	15.20	17.82		<b>SG80S 120B – 0812N</b>

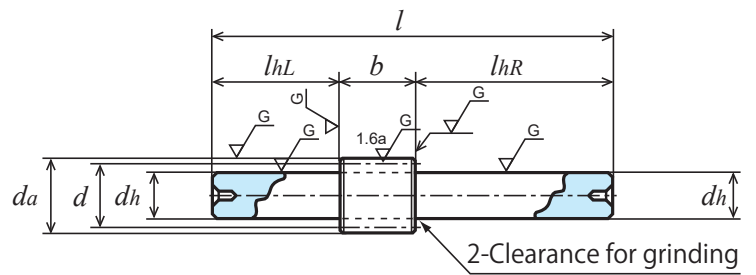

L1 type

Unit: mm

Accuracy Class	Material	Pressure angle	Heat treatment	Tooth surface hardness	Backlash ①
[JIS B 1702-1] N5	SCM435/440	20°	Induction hardening of teeth	HRC49 to 55	See the table below

★ No surface treatment is applied. [\*] Two screw holes and set screws are provided.

★ This allowable transfer capability table was prepared by using the formulas presented by the JGMA (Japan Gear Manufacturers Association). For the unit conversion method, refer to P. 20 in "References."

① This is a theoretical value obtained when a pair of gears of the same type and material are meshed with each other.

Catalogue number	Number of teeth <i>z</i>	Reference diameter <i>d</i>	Tip diameter <i>da</i>	Type	Face width <i>b</i>	Hole diameter <i>da(H7)</i>	Hub diameter <i>dh</i>	Hub length <i>lh</i>	Overall length <i>l</i>	Screw		Weight <i>W(kg)</i>
										<i>M</i>	<i>ls</i>	
<b>SG1S 14B – 1005N</b>	14	φ14	φ16	B1	10	φ 5	φ11	10	20	-	-	0.016
<b>SG1S 15L – 1010</b>	15	φ15	φ17	L1		-	φ10(h7)	L25 R60	95	-	-	0.066
<b>SG1S 15B – 1006N</b>	15	φ15	φ17	B1		φ 6	φ12	10	20	-	-	0.018
<b>SG1S 16L – 1010</b>	16	φ16	φ18	L1		-	φ10(h7)	L25 R60	95	-	-	0.068
<b>SG1S 16B – 1006N</b>	16	φ16	φ18	B1		φ 6	φ13	10	20	-	-	0.022
<b>SG1S 17B – 1006</b>	17	φ17	φ19	B1		φ 6	φ12	10	20	-	-	0.022
<b>SG1S 17B – 1006N</b>	17	φ17	φ19	B1		φ 6	φ14	10	20	-	-	0.025
<b>SG1S 18L – 1010</b>	18	φ18	φ20	L1		-	φ10(h7)	L25 R60	95	-	-	0.072
<b>SG1S 18B – 1006N</b>	18	φ18	φ20	B1		φ 6	φ15	10	20	-	-	0.029
<b>SG1S 18B – 1008</b>	18	φ18	φ20			φ 8	φ15			-	-	0.026
<b>SG1S 19B – 1006N</b>	19	φ19	φ21			φ 6	φ16			-	-	0.034
<b>SG1S 20B – 1006N</b>	20	φ20	φ22			φ 6	φ16			-	-	0.036
<b>SG1S 20B – 1008</b>	20	φ20	φ22			φ 8	φ16			-	-	0.032
<b>SG1S 20B * 1010</b>	20	φ20	φ22			φ10	φ16			2-M4	5	0.028
<b>SG1S 21B – 1008N</b>	21	φ21	φ23			φ 8	φ18			-	-	0.039
<b>SG1S 22B – 1008N</b>	22	φ22	φ24			φ 8	φ18			-	-	0.042
<b>SG1S 23B – 1008N</b>	23	φ23	φ25			φ 8	φ20			-	-	0.049
<b>SG1S 24B – 1008N</b>	24	φ24	φ26			φ 8	φ20			-	-	0.052
<b>SG1S 25B – 1008</b>	25	φ25	φ27		φ 8	φ20	-			-	0.055	
<b>SG1S 26B – 1008N</b>	26	φ26	φ28		φ 8	φ20	-			-	0.058	
<b>SG1S 27B – 1008N</b>	27	φ27	φ29		φ 8	φ20	-			-	0.062	
<b>SG1S 28B – 1008N</b>	28	φ28	φ30		φ 8	φ20	-			-	0.065	
<b>SG1S 29B – 1008N</b>	29	φ29	φ31		φ 8	φ25	-			-	0.082	
<b>SG1S 30B – 1010</b>	30	φ30	φ32		φ10	φ26	-			-	0.084	
<b>SG1S 30B – 1010N</b>	30	φ30	φ32		φ10	φ25	-			-	0.082	
<b>SG1S 32B – 1010N</b>	32	φ32	φ34		φ10	φ25	-			-	0.089	
<b>SG1S 34B – 1010N</b>	34	φ34	φ36	φ10	φ25	-	-	0.097				
<b>SG1S 35B – 1010</b>	35	φ35	φ37	φ10	φ26	-	-	0.104				
<b>SG1S 35B – 1010N</b>	35	φ35	φ37	φ10	φ25	-	-	0.102				
<b>SG1S 36B – 1010</b>	36	φ36	φ38	φ10	φ26	-	-	0.109				
<b>SG1S 36B – 1010N</b>	36	φ36	φ38	φ10	φ25	-	-	0.106				
<b>SG1S 38B – 1010N</b>	38	φ38	φ40	φ10	φ30	-	-	0.132				
<b>SG1S 40B – 1010N</b>	40	φ40	φ42	φ10	φ30	-	-	0.142				
<b>SG1S 42B – 1010N</b>	42	φ42	φ44	φ10	φ30	-	-	0.152				
<b>SG1S 44B – 1010</b>	44	φ44	φ46	φ10	φ35	-	-	0.181				
<b>SG1S 44B – 1010N</b>	44	φ44	φ46	φ10	φ30	-	-	0.163				
<b>SG1S 45B – 1010N</b>	45	φ45	φ47	φ10	φ30	-	-	0.168				
<b>SG1S 45B – 1012</b>	45	φ45	φ47	φ12	φ35	-	-	0.182				
<b>SG1S 48B – 1010N</b>	48	φ48	φ50	φ10	φ30	-	-	0.185				
<b>SG1S 48B – 1012</b>	48	φ48	φ50	φ12	φ35	-	-	0.199				

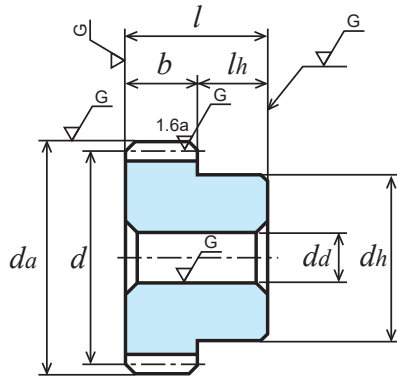

B1 type [-]

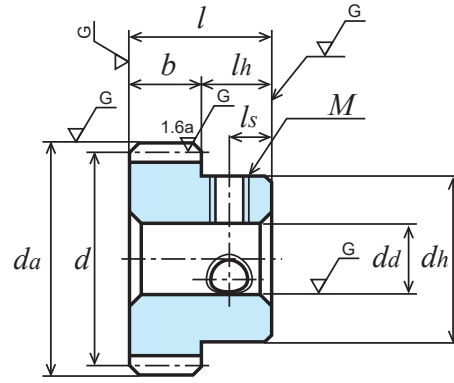

B1 type [\*]

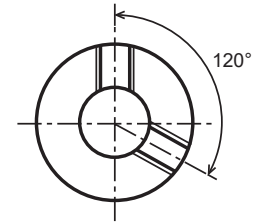

Allowable transfer capability table for different revolutions per minute, Bending strength, (Unit: kW)								Allowable transfer capability table for different revolutions per minute, Surface durability, (Unit: kW)								Backlash (Unit: mm)	Catalogue number
400 rpm	800 rpm	1,200 rpm	1,500 rpm	1,800 rpm	2,500 rpm	3,000 rpm	400 rpm	800 rpm	1,200 rpm	1,500 rpm	1,800 rpm	2,500 rpm	3,000 rpm				
0.30	0.61	0.92	1.15	1.38	1.92	2.30	0.062	0.12	0.19	0.23	0.28	0.40	0.48	0.04 to 0.08	<b>SG1S 14B – 1005N</b>		
0.34	0.68	1.03	1.29	1.55	2.15	2.58	0.072	0.14	0.22	0.27	0.33	0.46	0.56		<b>SG1S 15L – 1010</b>		
0.34	0.68	1.03	1.29	1.55	2.15	2.58	0.072	0.14	0.22	0.27	0.33	0.46	0.56		<b>SG1S 15B – 1006N</b>		
0.38	0.76	1.14	1.43	1.72	2.39	2.87	0.082	0.16	0.25	0.31	0.38	0.53	0.64		<b>SG1S 16L – 1010</b>		
0.38	0.76	1.14	1.43	1.72	2.39	2.87	0.082	0.16	0.25	0.31	0.38	0.53	0.64		<b>SG1S 16B – 1006N</b>		
0.42	0.84	1.26	1.57	1.89	2.63	3.15	0.093	0.18	0.28	0.35	0.43	0.60	0.73		<b>SG1S 17B – 1006</b>		
0.42	0.84	1.26	1.57	1.89	2.63	3.15	0.093	0.18	0.28	0.35	0.43	0.60	0.73		<b>SG1S 17B – 1006N</b>		
0.46	0.92	1.38	1.72	2.07	2.87	3.45	0.105	0.21	0.32	0.40	0.48	0.68	0.82		<b>SG1S 18L – 1010</b>		
0.46	0.92	1.38	1.72	2.07	2.87	3.45	0.105	0.21	0.32	0.40	0.48	0.68	0.82		<b>SG1S 18B – 1006N</b>		
0.46	0.92	1.38	1.72	2.07	2.87	3.45	0.105	0.21	0.32	0.40	0.48	0.68	0.82		<b>SG1S 18B – 1008</b>		
0.50	1.00	1.51	1.88	2.26	3.10	3.69	0.116	0.23	0.35	0.45	0.54	0.76	0.90		<b>SG1S 19B – 1006N</b>		
0.54	1.08	1.62	2.02	2.43	3.37	4.03	0.130	0.26	0.39	0.50	0.60	0.85	1.02		<b>SG1S 20B – 1006N</b>		
0.54	1.08	1.62	2.02	2.43	3.37	4.03	0.130	0.26	0.39	0.50	0.60	0.85	1.02		<b>SG1S 20B – 1008</b>		
0.54	1.08	1.62	2.02	2.43	3.37	4.03	0.130	0.26	0.39	0.50	0.60	0.85	1.02		<b>SG1S 20B * 1010</b>		
0.58	1.16	1.74	2.17	2.61	3.62	4.32	0.144	0.29	0.44	0.55	0.67	0.94	1.13		<b>SG1S 21B – 1008N</b>		
0.62	1.24	1.86	2.33	2.79	3.88	4.60	0.158	0.32	0.48	0.61	0.73	1.03	1.24		<b>SG1S 22B – 1008N</b>		
0.66	1.32	1.98	2.48	2.98	4.14	4.89	0.174	0.35	0.53	0.67	0.81	1.14	1.35		<b>SG1S 23B – 1008N</b>		
0.70	1.40	2.11	2.64	3.16	4.38	5.18	0.190	0.38	0.58	0.73	0.88	1.24	1.48		<b>SG1S 24B – 1008N</b>		
0.74	1.49	2.23	2.79	3.35	4.63	5.46	0.20	0.41	0.63	0.79	0.96	1.34	1.60		<b>SG1S 25B – 1008</b>		
0.78	1.57	2.36	2.95	3.54	4.87	5.75	0.22	0.45	0.68	0.86	1.04	1.45	1.73		<b>SG1S 26B – 1008N</b>		
0.83	1.66	2.49	3.11	3.73	5.12	6.04	0.24	0.49	0.74	0.93	1.13	1.57	1.87		<b>SG1S 27B – 1008N</b>		
0.87	1.74	2.62	3.27	3.93	5.37	6.33	0.26	0.52	0.80	1.01	1.22	1.69	2.01		<b>SG1S 28B – 1008N</b>		
0.91	1.82	2.74	3.41	4.11	5.64	6.71	0.282	0.57	0.86	1.09	1.31	1.83	2.19		<b>SG1S 29B – 1008N</b>		
0.95	1.91	2.87	3.59	4.31	5.85	6.89	0.30	0.61	0.92	1.16	1.41	1.94	2.31		<b>SG1S 30B – 1010</b>		
0.95	1.91	2.87	3.59	4.31	5.85	6.89	0.30	0.61	0.92	1.16	1.41	1.94	2.31		<b>SG1S 30B – 1010N</b>		
1.04	2.09	3.13	3.92	4.70	6.34	7.46	0.34	0.69	1.05	1.33	1.61	2.21	2.62		<b>SG1S 32B – 1010N</b>		
1.13	2.26	3.40	4.25	5.07	6.83	8.05	0.38	0.79	1.20	1.51	1.82	2.49	2.96		<b>SG1S 34B – 1010N</b>		
1.17	2.35	3.53	4.41	5.25	7.07	8.34	0.41	0.83	1.27	1.60	1.93	2.64	3.14		<b>SG1S 35B – 1010</b>		
1.17	2.35	3.53	4.41	5.25	7.07	8.34	0.41	0.83	1.27	1.60	1.93	2.64	3.14		<b>SG1S 35B – 1010N</b>		
1.22	2.44	3.66	4.58	5.44	7.32	8.63	0.43	0.89	1.35	1.70	2.04	2.79	3.33		<b>SG1S 36B – 1010</b>		
1.22	2.44	3.66	4.58	5.44	7.32	8.63	0.43	0.89	1.35	1.70	2.04	2.79	3.33		<b>SG1S 36B – 1010N</b>		
1.31	2.62	3.93	4.93	5.81	7.80	9.21	0.49	0.99	1.51	1.91	2.27	3.11	3.71		<b>SG1S 38B – 1010N</b>		
1.40	2.88	4.20	5.23	6.18	8.30	9.80	0.54	1.11	1.69	2.12	2.53	3.45	4.12		<b>SG1S 40B – 1010N</b>		
1.49	2.98	4.47	5.54	6.54	8.79	10.37	0.60	1.23	1.87	2.34	2.79	3.81	4.54		<b>SG1S 42B – 1010N</b>		
1.58	3.16	4.73	5.85	6.90	9.28	10.94	0.66	1.35	2.06	2.57	3.06	4.18	4.98		<b>SG1S 44B – 1010</b>		
1.58	3.16	4.73	5.85	6.90	9.28	10.94	0.66	1.35	2.06	2.57	3.06	4.18	4.98		<b>SG1S 44B – 1010N</b>		
1.62	3.25	4.87	6.01	7.08	9.53	11.23	0.69	1.42	2.16	2.69	3.20	4.38	5.21		<b>SG1S 45B – 1010N</b>		
1.62	3.25	4.87	6.01	7.08	9.53	11.23	0.69	1.42	2.16	2.69	3.20	4.38	5.21		<b>SG1S 45B – 1012</b>		
1.76	3.52	5.27	6.47	7.62	10.26	12.08	0.70	1.62	2.47	3.06	3.64	4.98	5.93		<b>SG1S 48B – 1010N</b>		
1.76	3.52	5.27	6.47	7.62	10.26	12.08	0.70	1.62	2.47	3.06	3.64	4.98	5.93		<b>SG1S 48B – 1012</b>		

- CONTENTS
- INFORMATION
- GEARBOXES
- ANTI-BACKLASH SPUR GEARS
- SPUR GEARS
- RACKS
- HELICAL GEARS AND SCREW GEARS
- MITER GEARS
- BEVEL GEARS
- WORMS AND WORM WHEELS
- REFERENCES



Unit: mm

Accuracy Class	Material	Pressure angle	Heat treatment	Tooth surface hardness	Backlash ①
[JIS B 1702-1] N5	SCM435/440	20°	Induction hardening of teeth	HRC49 to 55	See the table below

★ No surface treatment is applied.

★ This allowable transfer capability table was prepared by using the formulas presented by the JGMA (Japan Gear Manufacturers Association). For the unit conversion method, refer to P. 20 in "References."

① This is a theoretical value obtained when a pair of gears of the same type and material are meshed with each other.

Catalogue number	Number of teeth <i>z</i>	Reference diameter <i>d</i>	Tip diameter <i>d<sub>a</sub></i>	Type	Face width <i>b</i>	Hole diameter <i>d<sub>a</sub>(H7)</i>	Hub diameter <i>d<sub>h</sub></i>	Hub length <i>l<sub>h</sub></i>	Overall length <i>l</i>	Weight <i>W(kg)</i>
SG1S 50B – 1012	50	φ 50	φ 52	B1	10	φ 12	φ 35	10	20	0.21
SG1S 50B – 1015	50	φ 50	φ 52			φ 15	φ 35			0.20
SG1S 52B – 1012	52	φ 52	φ 54			φ 12	φ 35			0.23
SG1S 54B – 1012	54	φ 54	φ 56			φ 12	φ 35			0.24
SG1S 55B – 1012N	55	φ 55	φ 57			φ 12	φ 35			0.24
SG1S 56B – 1012	56	φ 56	φ 58			φ 12	φ 35			0.25
SG1S 60B – 1012	60	φ 60	φ 62			φ 12	φ 40			0.30
SG1S 60B – 1015	60	φ 60	φ 62			φ 15	φ 40			0.29
SG1S 60B – 1018	60	φ 60	φ 62			φ 18	φ 40			0.28
SG1S 64B – 1012N	64	φ 64	φ 66			φ 12	φ 40			0.33
SG1S 70B – 1012	70	φ 70	φ 72			φ 12	φ 40			0.38
SG1S 75B – 1012N	75	φ 75	φ 77			φ 12	φ 40			0.43
SG1S 80B – 1012	80	φ 80	φ 82			φ 12	φ 45			0.50
SG1S 80B – 1020	80	φ 80	φ 82			φ 20	φ 45			0.47
SG1S 80B – 1015N	80	φ 80	φ 82			φ 15	φ 50			0.52
SG1S 90B – 1015	90	φ 90	φ 92			φ 15	φ 50			0.62
SG1S 100B – 1015N	100	φ 100	φ 102			φ 15	φ 50			0.74
SG1S 100B – 1020	100	φ 100	φ 102			φ 20	φ 50			0.72
SG1S 108B – 1015	108	φ 108	φ 110			φ 15	φ 50			0.84
SG1S 120B – 1015	120	φ 120	φ 122			φ 15	φ 50			1.01



2D • 3D CAD

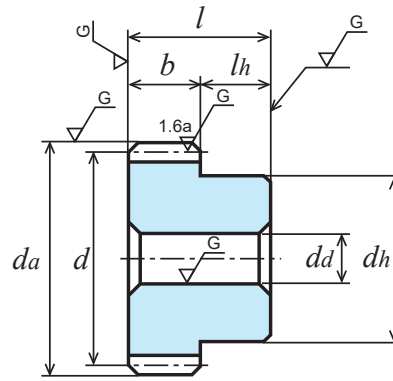

B1 type [-]

Allowable transfer capability table for different revolutions per minute, Bending strength, (Unit: kW)							Allowable transfer capability table for different revolutions per minute, Surface durability, (Unit: kW)							Backlash (Unit: mm)	Catalogue number
400 rpm	800 rpm	1,200 rpm	1,500 rpm	1,800 rpm	2,500 rpm	3,000 rpm	400 rpm	800 rpm	1,200 rpm	1,500 rpm	1,800 rpm	2,500 rpm	3,000 rpm		
1.85	3.70	5.53	6.78	7.98	10.75	12.64	0.86	1.76	2.68	3.32	3.94	5.41	6.43	0.04 to 0.08	<b>SG1S 50B – 1012</b>
1.85	3.70	5.53	6.78	7.98	10.75	12.64	0.86	1.76	2.68	3.32	3.94	5.41	6.43		<b>SG1S 50B – 1015</b>
1.94	3.88	5.78	7.09	8.34	11.23	13.18	0.94	1.91	2.90	3.59	4.26	5.85	6.94		<b>SG1S 52B – 1012</b>
2.03	4.06	6.04	7.39	8.70	11.71	13.71	1.01	2.07	3.13	3.87	4.60	6.31	7.46		<b>SG1S 54B – 1012</b>
2.08	4.16	6.16	7.54	8.88	11.95	13.97	1.05	2.15	3.24	4.01	4.77	6.54	7.73		<b>SG1S 55B – 1012N</b>
2.12	4.25	6.29	7.70	9.06	12.19	14.23	1.09	2.23	3.36	4.16	4.95	6.78	8.00		<b>SG1S 56B – 1012</b>
2.31	4.62	6.79	8.30	9.79	13.14	15.24	1.26	2.58	3.86	4.77	5.69	7.78	9.12		<b>SG1S 60B – 1012</b>
2.31	4.62	6.79	8.30	9.79	13.14	15.24	1.26	2.58	3.86	4.77	5.69	7.78	9.12		<b>SG1S 60B – 1015</b>
2.31	4.62	6.79	8.30	9.79	13.14	15.24	1.26	2.58	3.86	4.77	5.69	7.78	9.12		<b>SG1S 60B – 1018</b>
2.49	4.99	7.29	8.90	10.51	14.04	16.24	1.44	2.95	4.39	5.43	6.47	8.82	10.31		<b>SG1S 64B – 1012N</b>
2.77	5.54	8.03	9.82	11.58	15.34	17.69	1.73	3.56	5.26	6.50	7.75	10.47	12.20		<b>SG1S 70B – 1012</b>
3.00	5.99	8.64	10.58	12.47	16.39	18.86	2.00	4.09	6.03	7.47	8.90	11.93	13.88		<b>SG1S 75B – 1012N</b>
3.24	6.42	9.25	11.33	13.34	17.42	20.08	2.29	4.66	6.85	8.51	10.12	13.48	15.70		<b>SG1S 80B – 1012</b>
3.24	6.42	9.25	11.33	13.34	17.42	20.08	2.29	4.66	6.85	8.51	10.12	13.48	15.70		<b>SG1S 80B – 1020</b>
3.24	6.42	9.25	11.33	13.34	17.42	20.08	2.29	4.66	6.85	8.51	10.12	13.48	15.70		<b>SG1S 80B – 1015N</b>
3.70	7.26	10.47	12.80	14.98	19.37	22.47	2.92	5.90	8.69	10.77	12.74	16.80	19.69		<b>SG1S 90B – 1015</b>
4.17	8.10	11.68	14.25	16.53	21.40	24.80	3.64	7.29	10.74	13.28	15.57	20.56	24.07		<b>SG1S 100B – 1015N</b>
4.17	8.10	11.68	14.25	16.53	21.40	24.80	3.64	7.29	10.74	13.28	15.57	20.56	24.07		<b>SG1S 100B – 1020</b>
4.55	8.76	12.64	15.34	17.73	23.01	26.60	4.27	8.50	12.53	15.42	18.01	23.84	27.84		<b>SG1S 108B – 1015</b>
5.12	9.74	14.05	16.89	19.46	25.34	28.97	5.32	10.48	15.47	18.85	21.95	29.13	33.64		<b>SG1S 120B – 1015</b>





Unit: mm

Accuracy Class	Material	Pressure angle	Heat treatment	Tooth surface hardness	Backlash ①
[JIS B 1702-1] N5	SCM435/440	20°	Induction hardening of teeth	HRC49 to 55	See the table below

★ No surface treatment is applied.

★ This allowable transfer capability table was prepared by using the formulas presented by the JGMA (Japan Gear Manufacturers Association). For the unit conversion method, refer to P. 20 in "References."

① This is a theoretical value obtained when a pair of gears of the same type and material are meshed with each other.

Catalogue number	Number of teeth <i>z</i>	Reference diameter <i>d</i>	Tip diameter <i>d<sub>a</sub></i>	Type	Face width <i>b</i>	Hole diameter <i>d<sub>a</sub>(H7)</i>	Hub diameter <i>d<sub>h</sub></i>	Hub length <i>l<sub>h</sub></i>	Overall length <i>l</i>	Weight <i>W(kg)</i>	
<b>SG1.5S 14L – 1512</b>	14	φ 21	φ 24	L1	15	-	φ12(h7)	L25 R60	100	0.12	
<b>SG1.5S 14B – 1510N</b>	14	φ 21	φ 24	B1		φ10	φ17	14	29	0.05	
<b>SG1.5S 15B – 1510N</b>	15	φ 22.5	φ 25.5			φ10	φ18	14	29	0.06	
<b>SG1.5S 16B – 1510N</b>	16	φ 24	φ 27			φ10	φ20	14	29	0.07	
<b>SG1.5S 17B – 1510N</b>	17	φ 25.5	φ 28.5			φ10	φ21	14	29	0.08	
<b>SG1.5S 18B – 1510N</b>	18	φ 27	φ 30			φ10	φ22	14	29	0.09	
<b>SG1.5S 19B – 1510N</b>	19	φ 28.5	φ 31.5			φ10	φ23	14	29	0.10	
<b>SG1.5S 20B – 1510N</b>	20	φ 30	φ 33			φ10	φ24	14	29	0.12	
<b>SG1.5S 21B – 1510N</b>	21	φ 31.5	φ 34.5			φ10	φ25	14	29	0.13	
<b>SG1.5S 22B – 1512N</b>	22	φ 33	φ 36			φ12	φ26	14	29	0.13	
<b>SG1.5S 23B – 1512N</b>	23	φ 34.5	φ 37.5			φ12	φ27	14	29	0.15	
<b>SG1.5S 24B – 1515</b>	24	φ 36	φ 39			φ15	φ30	15	30	0.16	
<b>SG1.5S 24B – 1512N</b>	24	φ 36	φ 39				φ12	φ28	14	29	0.16
<b>SG1.5S 25B – 1512N</b>	25	φ 37.5	φ 40.5				φ12	φ30	14	29	0.18
<b>SG1.5S 26B – 1512N</b>	26	φ 39	φ 42				φ12	φ32	14	29	0.20
<b>SG1.5S 27B – 1515N</b>	27	φ 40.5	φ 43.5				φ15	φ34	14	29	0.21
<b>SG1.5S 28B – 1515N</b>	28	φ 42	φ 45				φ15	φ36	14	29	0.23
<b>SG1.5S 29B – 1515N</b>	29	φ 43.5	φ 46.5				φ15	φ37	14	29	0.25
<b>SG1.5S 30B – 1515</b>	30	φ 45	φ 48				φ15	φ35	15	30	0.26
<b>SG1.5S 30B – 1515N</b>	30	φ 45	φ 48				φ15	φ38	14	29	0.27
<b>SG1.5S 32B – 1515N</b>	32	φ 48	φ 51		φ15		φ40	14	29	0.31	
<b>SG1.5S 34B – 1515N</b>	34	φ 51	φ 54	φ15	φ42	14	29	0.35			
<b>SG1.5S 35B – 1515N</b>	35	φ 52.5	φ 55.5	φ15	φ42	14	29	0.37			
<b>SG1.5S 36B – 1515N</b>	36	φ 54	φ 57	φ15	φ45	14	29	0.40			
<b>SG1.5S 38B – 1515N</b>	38	φ 57	φ 60	φ15	φ45	14	29	0.44			



2D • 3D CAD

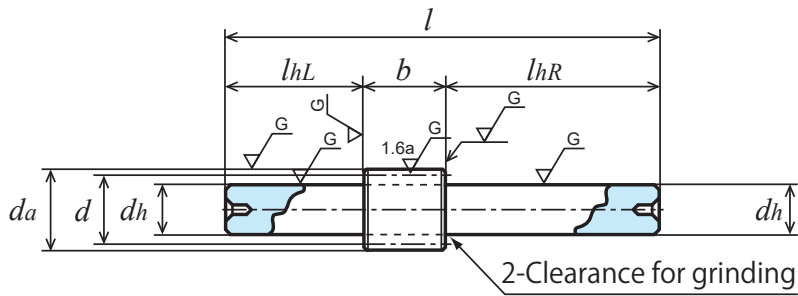

L1 type

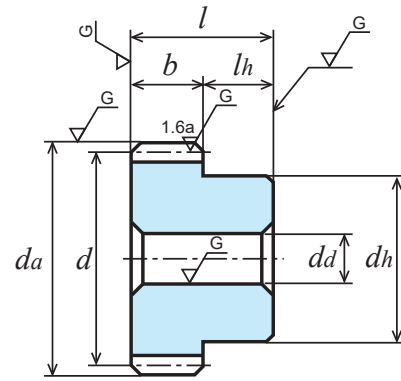

B1 type [-]

Allowable transfer capability table for different revolutions per minute, Bending strength, (Unit: kW)							Allowable transfer capability table for different revolutions per minute, Surface durability, (Unit: kW)							Backlash (Unit: mm)	Catalogue number
400 rpm	800 rpm	1,200 rpm	1,500 rpm	1,800 rpm	2,500 rpm	3,000 rpm	400 rpm	800 rpm	1,200 rpm	1,500 rpm	1,800 rpm	2,500 rpm	3,000 rpm		
1.03	2.07	3.11	3.89	4.67	6.49	7.73	0.21	0.43	0.66	0.83	1.00	1.41	1.69	0.06 to 0.12	<b>SG1.5S 14L – 1512</b>
1.03	2.07	3.11	3.89	4.67	6.49	7.73	0.21	0.43	0.66	0.83	1.00	1.41	1.69		<b>SG1.5S 14B – 1510N</b>
1.16	2.32	3.49	4.36	5.23	7.27	8.61	0.24	0.50	0.76	0.96	1.16	1.63	1.95		<b>SG1.5S 15B – 1510N</b>
1.29	2.58	3.87	4.84	5.81	8.04	9.50	0.28	0.57	0.87	1.09	1.32	1.86	2.20		<b>SG1.5S 16B – 1510N</b>
1.42	2.84	4.26	5.33	6.39	8.81	10.40	0.32	0.65	0.99	1.24	1.50	2.10	2.50		<b>SG1.5S 17B – 1510N</b>
1.55	3.11	4.66	5.82	6.99	9.58	11.30	0.36	0.74	1.12	1.41	1.70	2.36	2.81		<b>SG1.5S 18B – 1510N</b>
1.68	3.38	5.06	6.33	7.59	10.36	12.21	0.40	0.83	1.25	1.58	1.90	2.63	3.13		<b>SG1.5S 19B – 1510N</b>
1.82	3.65	5.47	6.84	8.20	11.14	13.11	0.45	0.92	1.39	1.75	2.12	2.92	3.47		<b>SG1.5S 20B – 1510N</b>
1.96	3.92	5.88	7.35	8.80	11.91	14.02	0.50	1.01	1.54	1.94	2.18	3.22	3.82		<b>SG1.5S 21B – 1510N</b>
2.10	4.20	6.29	7.87	9.41	12.69	14.94	0.55	1.11	1.69	2.14	2.57	3.53	4.19		<b>SG1.5S 22B – 1512N</b>
2.24	4.47	6.71	8.39	10.00	13.47	15.87	0.60	1.22	1.86	2.35	2.62	3.85	4.59		<b>SG1.5S 23B – 1512N</b>
2.38	4.75	7.13	8.91	10.59	14.25	16.80	0.66	1.34	2.03	2.56	3.07	4.19	5.00		<b>SG1.5S 24B – 1515</b>
2.38	4.75	7.13	8.91	10.59	14.25	16.80	0.66	1.34	2.03	2.56	3.07	4.19	5.00		<b>SG1.5S 24B – 1512N</b>
2.52	5.04	7.55	9.44	11.18	15.02	17.74	0.72	1.45	2.21	2.79	3.33	4.55	5.42		<b>SG1.5S 25B – 1512N</b>
2.66	5.32	7.98	9.96	11.77	15.81	18.67	0.78	1.58	2.40	3.02	3.60	4.92	5.87		<b>SG1.5S 26B – 1512N</b>
2.80	5.61	8.41	10.46	12.36	16.61	19.61	0.84	1.71	2.60	3.26	3.88	5.31	6.33		<b>SG1.5S 27B – 1515N</b>
2.95	5.90	8.84	10.97	12.96	17.41	20.54	0.90	1.84	2.80	3.51	4.18	5.71	6.81		<b>SG1.5S 28B – 1515N</b>
3.09	6.18	9.27	11.47	13.54	18.20	21.46	0.97	1.98	3.01	3.77	4.49	6.13	7.31		<b>SG1.5S 29B – 1515N</b>
3.24	6.47	9.71	11.98	14.13	19.00	22.39	1.04	2.12	3.23	4.03	4.80	6.57	7.82		<b>SG1.5S 30B – 1515</b>
3.24	6.47	9.71	11.98	14.13	19.00	22.39	1.04	2.12	3.23	4.03	4.80	6.57	7.82		<b>SG1.5S 30B – 1515N</b>
3.53	7.06	10.59	12.99	15.30	20.59	24.24	1.19	2.43	3.70	4.59	5.45	7.47	8.89	<b>SG1.5S 32B – 1515N</b>	
3.83	7.65	11.42	13.99	16.47	22.18	26.08	1.35	2.75	4.18	5.18	6.15	8.44	10.03	<b>SG1.5S 34B – 1515N</b>	
3.97	7.95	11.83	14.49	17.05	22.97	26.94	1.43	2.93	4.43	5.49	6.52	8.94	10.60	<b>SG1.5S 35B – 1515N</b>	
4.12	8.25	12.25	15.00	17.64	23.76	27.81	1.52	3.10	4.69	5.80	6.90	9.46	11.19	<b>SG1.5S 36B – 1515N</b>	
4.42	8.85	13.08	15.99	18.84	25.33	29.51	1.70	3.47	5.23	6.46	7.69	10.54	12.41	<b>SG1.5S 38B – 1515N</b>	

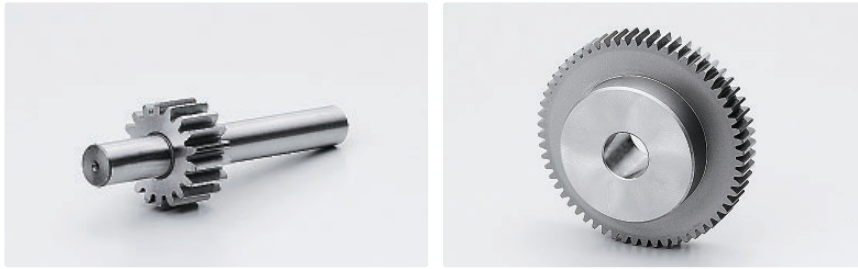

Unit: mm

Accuracy Class	Material	Pressure angle	Heat treatment	Tooth surface hardness	Backlash ①
[JIS B 1702-1] N5	SCM435/440	20°	Induction hardening of teeth	HRC49 to 55	See the table below

★ No surface treatment is applied.

★ This allowable transfer capability table was prepared by using the formulas presented by the JGMA (Japan Gear Manufacturers Association). For the unit conversion method, refer to P. 20 in "References."

① This is a theoretical value obtained when a pair of gears of the same type and material are meshed with each other.

Catalogue number	Number of teeth	Reference diameter	Tip diameter	Type	Face width	Hole diameter	Hub diameter	Hub length	Overall length	Weight
	$z$	$d$	$d_a$			$d_i$ (H7)	$d_h$	$l_h$	$l$	$W$ (kg)
<b>SG1.5S 40B – 1515</b>	40	φ 60	φ 63	B1	15	φ15	φ40	15	30	0.44
<b>SG1.5S 40B – 1515N</b>	40	φ 60	φ 63			φ15	φ50	14	29	0.51
<b>SG1.5S 42B – 1515N</b>	42	φ 63	φ 66			φ15	φ50	14	29	0.54
<b>SG1.5S 44B – 1515N</b>	44	φ 66	φ 69			φ15	φ50	14	29	0.58
<b>SG1.5S 45B – 1518N</b>	45	φ 67.5	φ 70.5			φ18	φ50	14	29	0.58
<b>SG1.5S 48B – 1518N</b>	48	φ 72	φ 75			φ18	φ50	14	29	0.64
<b>SG1.5S 50B – 1520</b>	50	φ 75	φ 78			φ20	φ50	15	30	0.67
<b>SG1.5S 50B – 1518N</b>	50	φ 75	φ 78			φ18	φ60	14	29	0.77
<b>SG1.5S 55B – 1518N</b>	55	φ 82.5	φ 85.5			φ18	φ60	14	29	0.88
<b>SG1.5S 56B – 1518N</b>	56	φ 84	φ 87			φ18	φ60	14	29	0.91
<b>SG1.5S 60B – 1520N</b>	60	φ 90	φ 93			φ20	φ60	14	29	0.99
<b>SG1.5S 64B – 1520N</b>	64	φ 96	φ 99			φ20	φ60	14	29	1.09
<b>SG1.5S 70B – 1520</b>	70	φ105	φ108			φ20	φ60	15	30	1.27
<b>SG1.5S 70B – 1520N</b>	70	φ105	φ108			φ20	φ60	14	29	1.26
<b>SG1.5S 72B – 1520</b>	72	φ108	φ111			φ20	φ60	15	30	1.33
<b>SG1.5S 75B – 1520N</b>	75	φ112.5	φ115.5			φ20	φ60	14	29	1.41
<b>SG1.5S 80B – 1520</b>	80	φ120	φ123			φ20	φ60	15	30	1.58
<b>SG1.5S 80B – 1520N</b>	80	φ120	φ123			φ20	φ70	14	29	1.68
<b>SG1.5S 90B – 1520N</b>	90	φ135	φ138			φ20	φ70	14	29	2.04
<b>SG1.5S 100B – 1520N</b>	100	φ150	φ153			φ20	φ70	14	29	2.43
<b>SG1.5S 120B – 1525</b>	120	φ180	φ183	φ25	φ70	15	30	3.31		



2D • 3D CAD

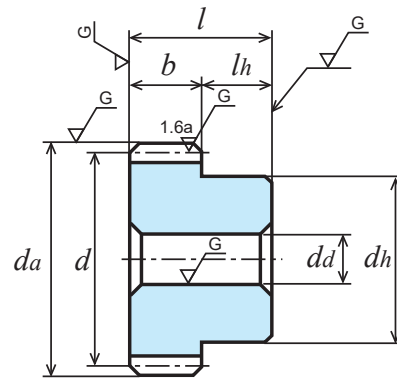

B1 type [-]

Allowable transfer capability table for different revolutions per minute, Bending strength, (Unit: kW)							Allowable transfer capability table for different revolutions per minute, Surface durability, (Unit: kW)							Backlash (Unit: mm)	Catalogue number
400 rpm	800 rpm	1,200 rpm	1,500 rpm	1,800 rpm	2,500 rpm	3,000 rpm	400 rpm	800 rpm	1,200 rpm	1,500 rpm	1,800 rpm	2,500 rpm	3,000 rpm		
4.72	9.45	13.90	16.98	20.03	26.90	31.19	1.89	3.87	5.79	7.16	8.53	11.67	13.69	0.06 to 0.12	<b>SG1.5S 40B – 1515</b>
4.72	9.45	13.90	16.98	20.03	26.90	31.19	1.89	3.87	5.79	7.16	8.53	11.67	13.69		<b>SG1.5S 40B – 1515N</b>
5.03	10.05	14.72	17.97	21.22	28.40	32.85	2.09	4.28	6.39	7.89	9.41	12.83	15.01		<b>SG1.5S 42B – 1515N</b>
5.33	10.66	15.55	18.99	22.42	29.83	34.46	2.30	4.72	7.02	8.67	10.34	14.03	16.38		<b>SG1.5S 44B – 1515N</b>
5.48	10.96	15.94	19.47	22.98	30.55	35.27	2.41	4.94	7.33	9.06	10.81	14.65	17.10		<b>SG1.5S 45B – 1518N</b>
5.94	11.87	17.16	20.98	24.74	32.67	37.64	2.76	5.66	8.34	10.32	12.30	16.56	19.29		<b>SG1.5S 48B – 1518N</b>
6.24	12.44	17.96	21.99	25.91	34.07	39.20	3.00	6.14	9.04	11.21	13.34	17.90	20.82		<b>SG1.5S 50B – 1520</b>
6.24	12.44	17.96	21.99	25.91	34.07	39.20	3.00	6.14	9.04	11.21	13.34	17.90	20.82		<b>SG1.5S 50B – 1518N</b>
7.01	13.87	19.98	24.48	28.79	37.47	43.26	3.66	7.44	10.94	13.57	16.14	21.42	25.00		<b>SG1.5S 55B – 1518N</b>
7.17	14.15	20.39	24.97	29.36	38.14	44.07	3.80	7.71	11.35	14.07	16.72	22.15	25.88		<b>SG1.5S 56B – 1518N</b>
7.79	15.29	22.03	26.94	31.52	40.76	47.28	4.39	8.86	13.04	16.15	19.11	25.19	29.54		<b>SG1.5S 60B – 1520N</b>
8.41	16.41	23.65	28.88	33.62	43.48	50.43	5.02	10.08	14.85	18.37	21.61	28.51	33.41		<b>SG1.5S 64B – 1520N</b>
9.35	18.07	26.06	31.71	36.68	47.56	55.02	6.05	12.05	17.77	21.91	25.62	33.87	39.60		<b>SG1.5S 70B – 1520</b>
9.35	18.07	26.06	31.71	36.68	47.56	55.02	6.05	12.05	17.77	21.91	25.62	33.87	39.60		<b>SG1.5S 70B – 1520N</b>
9.67	18.62	26.86	32.60	37.68	48.90	56.52	6.41	12.75	18.80	23.12	27.02	35.75	41.76		<b>SG1.5S 72B – 1520</b>
10.14	19.44	28.05	33.92	39.16	50.88	58.74	6.98	13.82	20.40	25.00	29.18	38.65	45.08		<b>SG1.5S 75B – 1520N</b>
10.93	20.80	30.01	36.08	41.57	54.12	61.89	7.99	15.72	23.20	28.27	32.93	43.70	50.47		<b>SG1.5S 80B – 1520</b>
10.93	20.80	30.01	36.08	41.57	54.12	61.89	7.99	15.72	23.20	28.27	32.93	43.70	50.47		<b>SG1.5S 80B – 1520N</b>
12.49	23.55	33.71	40.22	46.39	60.33	67.34	10.21	19.93	29.21	35.32	41.18	54.56	61.49		<b>SG1.5S 90B – 1520N</b>
14.03	26.28	37.20	44.20	51.28	65.34	72.38	12.68	24.63	35.71	43.00	50.42	65.43	73.16		<b>SG1.5S 100B – 1520N</b>
16.94	31.61	43.79	52.40	60.57	73.96	-	18.29	35.47	50.34	61.03	71.27	88.54	-	<b>SG1.5S 120B – 1525</b>	



Unit: mm

Accuracy Class	Material	Pressure angle	Heat treatment	Tooth surface hardness	Backlash ①
[JIS B 1702-1] N5	SCM435/440	20°	Induction hardening of teeth	HRC49 to 55	See the table below

★ No surface treatment is applied.

★ This allowable transfer capability table was prepared by using the formulas presented by the JGMA (Japan Gear Manufacturers Association). For the unit conversion method, refer to P. 20 in "References."

① This is a theoretical value obtained when a pair of gears of the same type and material are meshed with each other.

Catalogue number	Number of teeth <i>z</i>	Reference diameter <i>d</i>	Tip diameter <i>da</i>	Type	Face width <i>b</i>	Hole diameter <i>da(H7)</i>	Hub diameter <i>d<sub>h</sub></i>	Hub length <i>l<sub>h</sub></i>	Overall length <i>l</i>	Weight <i>W(kg)</i>
SG2S 14B – 2012N	14	φ 28	φ 32	B1	20	φ12	φ22	16	36	0.11
SG2S 15B – 2012	15	φ 30	φ 34	B1		φ12	φ22	20	40	0.13
SG2S 15B – 2012N	15	φ 30	φ 34	B1		φ12	φ24	16	36	0.14
SG2S 16L – 2015	16	φ 32	φ 36	L1		-	φ15(h7)	L25 R60	105	0.24
SG2S 16B – 2012N	16	φ 32	φ 36	B1		φ12	φ26	16	36	0.16
SG2S 17B – 2012N	17	φ 34	φ 38			φ12	φ28	16	36	0.19
SG2S 18B – 2012N	18	φ 36	φ 40			φ12	φ30	16	36	0.22
SG2S 19B – 2012N	19	φ 38	φ 42			φ12	φ31	16	36	0.24
SG2S 20B – 2015N	20	φ 40	φ 44			φ15	φ32	16	36	0.25
SG2S 21B – 2015N	21	φ 42	φ 46			φ15	φ34	16	36	0.28
SG2S 22B – 2015N	22	φ 44	φ 48			φ15	φ36	16	36	0.32
SG2S 23B – 2015N	23	φ 46	φ 50			φ15	φ37	16	36	0.35
SG2S 24B – 2015N	24	φ 48	φ 52			φ15	φ38	16	36	0.38
SG2S 25B – 2015N	25	φ 50	φ 54			φ15	φ40	16	36	0.42
SG2S 26B – 2015N	26	φ 52	φ 56			φ15	φ42	16	36	0.46
SG2S 27B – 2015N	27	φ 54	φ 58			φ15	φ44	16	36	0.50
SG2S 28B – 2015N	28	φ 56	φ 60			φ15	φ45	16	36	0.54
SG2S 29B – 2015N	29	φ 58	φ 62			φ15	φ48	16	36	0.59
SG2S 30B – 2018N	30	φ 60	φ 64			φ18	φ50	16	36	0.62
SG2S 32B – 2020	32	φ 64	φ 68			φ20	φ50	20	40	0.71
SG2S 32B – 2018N	32	φ 64	φ 68			φ18	φ50	16	36	0.68
SG2S 34B – 2018N	34	φ 68	φ 72			φ18	φ50	16	36	0.74
SG2S 35B – 2018N	35	φ 70	φ 74			φ18	φ50	16	36	0.78
SG2S 36B – 2018N	36	φ 72	φ 76			φ18	φ50	16	36	0.81
SG2S 38B – 2018N	38	φ 76	φ 80			φ18	φ50	16	36	0.89
SG2S 40B – 2020	40	φ 80	φ 84			φ20	φ60	20	40	1.13
SG2S 40B – 2020N	40	φ 80	φ 84			φ20	φ60	16	36	1.06
SG2S 42B – 2020N	42	φ 84	φ 88			φ20	φ60	16	36	1.14
SG2S 44B – 2020N	44	φ 88	φ 92			φ20	φ60	16	36	1.22
SG2S 45B – 2020N	45	φ 90	φ 94			φ20	φ60	16	36	1.27
SG2S 48B – 2020N	48	φ 96	φ100		φ20	φ60	16	36	1.40	
SG2S 50B – 2020	50	φ100	φ104		φ20	φ60	20	40	1.57	
SG2S 50B – 2025N	50	φ100	φ104		φ25	φ60	16	36	1.45	
SG2S 55B – 2025N	55	φ110	φ114		φ25	φ60	16	36	1.71	
SG2S 56B – 2025N	56	φ112	φ116	φ25	φ60	16	36	1.76		
SG2S 60B – 2025	60	φ120	φ124	φ25	φ70	20	40	2.21		
SG2S 60B – 2025N	60	φ120	φ124	φ25	φ65	16	36	2.05		
SG2S 64B – 2025N	64	φ128	φ132	φ25	φ65	16	36	2.30		
SG2S 70B – 2025N	70	φ140	φ144	φ25	φ70	16	36	2.76		
SG2S 72B – 2025N	72	φ144	φ148	φ25	φ70	16	36	2.90		
SG2S 75B – 2025N	75	φ150	φ154	φ25	φ70	16	36	3.12		
SG2S 80B – 2025	80	φ160	φ164	φ25	φ80	20	40	3.77		
SG2S 80B – 2025N	80	φ160	φ164	φ25	φ80	16	36	3.65		
SG2S 90B – 2025	90	φ180	φ184	φ25	φ80	20	40	4.60		
SG2S 90B – 2025N	90	φ180	φ184	φ25	φ80	16	36	4.49		
SG2S 100B – 2025N	100	φ200	φ204	φ25	φ80	16	36	5.42		

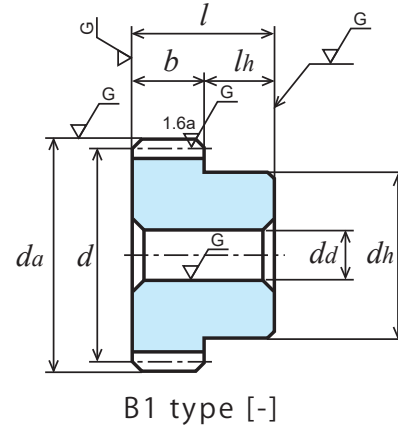
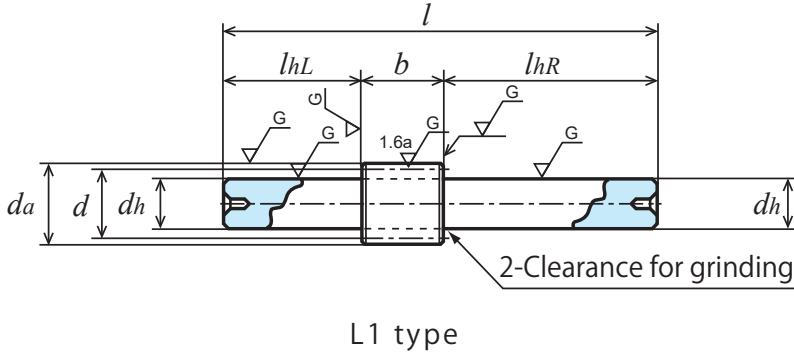

Allowable transfer capability table for different revolutions per minute, Bending strength, (Unit: kW)							Allowable transfer capability table for different revolutions per minute, Surface durability, (Unit: kW)							Backlash (Unit: mm)	Catalogue number
400 rpm	800 rpm	1,200 rpm	1,500 rpm	1,800 rpm	2,500 rpm	3,000 rpm	400 rpm	800 rpm	1,200 rpm	1,500 rpm	1,800 rpm	2,500 rpm	3,000 rpm		
2.46	4.92	7.39	9.23	11.08	15.13	17.84	0.52	1.06	1.60	2.02	2.44	3.39	4.03	0.08 to 0.16	SG2S 14B – 2012N
2.76	5.52	8.28	10.35	12.42	16.85	19.84	0.60	1.22	1.85	2.33	2.82	3.89	4.62		SG2S 15B – 2012
2.76	5.52	8.28	10.35	12.42	16.85	19.84	0.60	1.22	1.85	2.33	2.82	3.89	4.62		SG2S 15B – 2012N
3.06	6.12	9.19	11.48	13.77	18.58	21.86	0.69	1.39	2.12	2.67	3.23	4.42	5.25		SG2S 16L – 2015
3.06	6.12	9.19	11.48	13.77	18.58	21.86	0.69	1.39	2.12	2.67	3.23	4.42	5.25		SG2S 16B – 2012N
3.37	6.74	10.11	12.63	15.08	20.32	23.94	0.78	1.58	2.40	3.08	3.65	4.99	5.94		SG2S 17B – 2012N
3.68	7.36	11.04	13.80	16.40	22.06	26.02	0.88	1.78	2.71	3.41	4.09	5.59	6.66		SG2S 18B – 2012N
4.00	8.00	12.00	14.97	17.74	23.85	28.14	0.98	1.99	3.03	3.81	4.56	6.23	7.43		SG2S 19B – 2012N
4.32	8.64	12.96	16.15	19.08	25.63	30.25	1.09	2.22	3.37	4.24	5.05	6.90	8.23		SG2S 20B – 2015N
4.64	9.29	13.93	17.29	20.41	27.43	32.36	1.21	2.45	3.73	4.68	5.57	7.62	9.08		SG2S 21B – 2015N
4.97	9.94	14.92	18.44	21.75	29.25	34.47	1.33	2.70	4.11	5.14	6.11	8.37	9.97	SG2S 22B – 2015N	
5.30	10.61	15.91	19.59	23.09	31.06	36.59	1.45	2.96	4.51	5.62	6.68	9.15	10.89	SG2S 23B – 2015N	
5.63	11.27	16.90	20.73	24.42	32.87	38.68	1.59	3.24	4.93	6.12	7.27	9.97	11.86	SG2S 24B – 2015N	
5.97	11.94	17.84	21.88	25.76	34.68	40.79	1.73	3.52	5.36	6.64	7.89	10.82	12.86	SG2S 25B – 2015N	
6.31	12.61	18.79	23.03	27.09	36.49	42.84	1.87	3.82	5.80	7.18	8.53	11.70	13.88	SG2S 26B – 2015N	
6.65	13.29	19.75	24.17	28.44	38.30	44.83	2.03	4.14	6.25	7.74	9.19	12.62	14.92	SG2S 27B – 2015N	
6.99	13.98	20.70	25.32	29.82	40.11	46.80	2.18	4.66	6.73	8.32	9.90	13.57	16.00	SG2S 28B – 2015N	
7.33	14.66	21.64	26.45	31.18	41.89	48.74	2.35	4.91	7.22	8.92	10.62	14.55	17.11	SG2S 29B – 2015N	
7.67	15.35	22.59	27.59	32.55	43.69	50.68	2.52	5.15	7.72	9.55	11.37	15.56	18.25	SG2S 30B – 2018N	
8.37	16.76	24.48	29.87	35.28	47.14	54.51	2.88	5.90	8.79	10.85	12.95	17.64	20.62	SG2S 32B – 2020	
8.37	16.76	24.48	29.87	35.28	47.14	54.51	2.88	5.90	8.79	10.85	12.95	17.64	20.62	SG2S 32B – 2018N	
9.07	18.14	26.36	32.21	38.01	50.49	58.27	3.27	6.69	9.92	12.27	14.63	19.81	23.11	SG2S 34B – 2018N	
9.42	18.84	27.30	33.38	39.37	52.14	60.13	3.47	7.11	10.51	13.00	15.50	20.93	24.40	SG2S 35B – 2018N	
9.77	19.54	28.24	34.54	40.73	53.78	61.97	3.68	7.54	11.12	13.76	16.40	22.08	25.72	SG2S 36B – 2018N	
10.48	20.87	30.11	36.87	43.43	57.03	65.60	4.12	8.41	12.38	15.35	18.27	24.47	28.45	SG2S 38B – 2018N	
11.20	22.20	31.97	39.19	46.12	60.23	69.43	4.58	9.32	13.71	17.01	20.24	26.95	31.41	SG2S 40B – 2020	
11.20	22.20	31.97	39.19	46.12	60.23	69.43	4.58	9.32	13.71	17.01	20.24	26.95	31.41	SG2S 40B – 2020N	
11.91	23.52	33.89	41.49	48.80	63.37	73.24	5.07	10.28	15.13	18.76	22.30	29.54	34.50	SG2S 42B – 2020N	
12.62	24.82	35.77	43.76	51.30	66.42	76.96	5.58	11.29	16.62	20.59	24.40	32.22	37.73	SG2S 44B – 2020N	
12.99	25.48	36.72	44.90	52.55	67.94	78.82	5.85	11.81	17.38	21.53	25.47	33.59	39.39	SG2S 45B – 2020N	
14.07	27.44	39.56	48.31	56.23	72.72	84.34	6.69	13.44	19.80	24.49	28.82	38.01	44.55	SG2S 48B – 2020N	
14.80	28.74	41.44	50.56	58.64	75.93	87.96	7.28	14.58	21.49	26.56	31.15	41.12	48.14	SG2S 50B – 2020	
14.80	28.74	41.44	50.56	58.64	75.93	87.96	7.28	14.58	21.49	26.56	31.15	41.12	48.14	SG2S 50B – 2025N	
16.63	31.97	46.10	55.87	64.54	83.80	96.81	8.88	17.63	26.01	31.93	37.30	49.37	57.63	SG2S 55B – 2025N	
16.99	32.61	47.03	56.90	65.70	85.35	98.55	9.22	18.27	26.96	33.05	38.58	51.10	59.61	SG2S 56B – 2025N	
18.46	35.16	50.71	60.97	70.25	91.46	104.57	10.65	20.95	30.93	37.69	43.91	58.26	67.29	SG2S 60B – 2025	
18.46	35.16	50.71	60.97	70.25	91.46	104.57	10.65	20.95	30.93	37.69	43.91	58.26	67.29	SG2S 60B – 2025N	
19.94	37.77	54.34	64.96	74.72	97.43	109.96	12.18	23.87	35.16	42.59	49.53	65.82	75.02	SG2S 64B – 2025N	
22.17	41.66	59.39	70.76	81.78	105.82	117.59	14.69	28.59	41.75	50.41	58.89	77.64	87.09	SG2S 70B – 2025N	
22.90	42.94	61.04	72.65	84.09	108.14	120.01	15.58	30.26	44.06	53.14	62.17	81.44	91.23	SG2S 72B – 2025N	
23.95	44.86	63.49	75.44	87.52	111.53	123.54	16.91	32.84	47.61	57.34	67.23	87.25	97.54	SG2S 75B – 2025N	
25.68	48.04	67.49	80.31	93.15	116.96	-	19.26	37.38	53.80	64.88	76.04	97.20	-	SG2S 80B – 2025	
25.68	48.04	67.49	80.31	93.15	116.96	-	19.26	37.38	53.80	64.88	76.04	97.20	-	SG2S 80B – 2025N	
29.06	54.23	75.12	89.89	103.90	126.88	-	24.39	47.29	67.12	81.37	95.03	118.05	-	SG2S 90B – 2025	
29.06	54.23	75.12	89.89	103.90	126.88	-	24.39	47.29	67.12	81.37	95.03	118.05	-	SG2S 90B – 2025N	
32.41	60.17	82.79	99.19	113.41	-	-	30.11	58.13	81.94	99.45	114.85	-	-	SG2S 100B – 2025N	

- CONTENTS
- INFORMATION
- GEARBOXES
- ANTI-BACKLASH SPUR GEARS
- SPUR GEARS**
- RACKS
- HELICAL GEARS AND SCREW GEARS
- MITER GEARS
- BEVEL GEARS
- WORMS AND WORM WHEELS
- REFERENCES



Unit: mm

Accuracy Class	Material	Pressure angle	Heat treatment	Tooth surface hardness	Backlash ①
[JIS B 1702-1] N5	SCM435/440	20°	Induction hardening of teeth	HRC49 to 55	See the table below

★ No surface treatment is applied.

★ This allowable transfer capability table was prepared by using the formulas presented by the JGMA (Japan Gear Manufacturers Association). For the unit conversion method, refer to P. 20 in "References."

① This is a theoretical value obtained when a pair of gears of the same type and material are meshed with each other.

Catalogue number	Number of teeth	Reference diameter	Tip diameter	Type	Face width	Hole diameter	Hub diameter	Hub length	Overall length	Weight
	$z$	$d$	$d_a$		$b$	$d_a(H7)$	$d_h$	$l_h$	$l$	$W(kg)$
SG2.5S 14B – 2515N	14	φ 35	φ 40	B1	25	φ15	φ28	18	43	0.22
SG2.5S 15B – 2515N	15	φ 37.5	φ 42.5			φ15	φ30			0.26
SG2.5S 16B – 2515N	16	φ 40	φ 45			φ15	φ32			0.30
SG2.5S 18B – 2515N	18	φ 45	φ 50			φ15	φ38			0.41
SG2.5S 20B – 2518N	20	φ 50	φ 55			φ18	φ40			0.48
SG2.5S 24B – 2518N	24	φ 60	φ 65			φ18	φ48			0.72
SG2.5S 25B – 2520N	25	φ 62.5	φ 67.5			φ20	φ50			0.77
SG2.5S 28B – 2520N	28	φ 70	φ 75			φ20	φ60			1.05
SG2.5S 30B – 2520N	30	φ 75	φ 80			φ20	φ65			1.23
SG2.5S 32B – 2520N	32	φ 80	φ 85			φ20	φ70			1.42
SG2.5S 35B – 2520N	35	φ 87.5	φ 92.5			φ20	φ70			1.62
SG2.5S 36B – 2520N	36	φ 90	φ 95			φ20	φ70			1.69
SG2.5S 40B – 2525N	40	φ100	φ105			φ25	φ70			1.92
SG2.5S 45B – 2525N	45	φ112.5	φ117.5			φ25	φ75			2.41
SG2.5S 48B – 2525N	48	φ120	φ125			φ25	φ75			2.68
SG2.5S 50B – 2525N	50	φ125	φ130			φ25	φ80			2.95
SG2.5S 55B – 2525N	55	φ137.5	φ142.5			φ25	φ80			3.46
SG2.5S 56B – 2525N	56	φ140	φ145			φ25	φ80			3.57
SG2.5S 60B – 2525N	60	φ150	φ155			φ25	φ80			4.01
SG2.5S 64B – 2525N	64	φ160	φ165			φ25	φ80			4.49
SG2.5S 70B – 2525N	70	φ175	φ180	φ25	φ80	5.26				
SG2.5S 72B – 2525N	72	φ180	φ185	φ25	φ85	5.63				
SG2.5S 75B – 2525N	75	φ187.5	φ192.5	φ25	φ90	6.15				
SG2.5S 80B – 2525N	80	φ200	φ205	φ25	φ90	6.90				



2D • 3D CAD

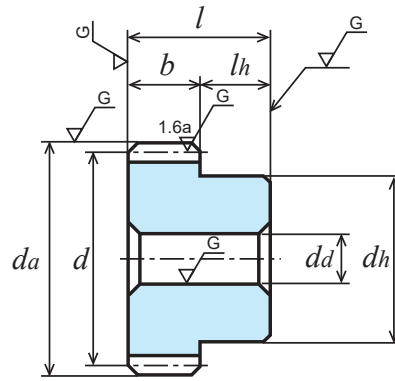

B1 type [-]

Allowable transfer capability table for different revolutions per minute, Bending strength, (Unit: kW)							Allowable transfer capability table for different revolutions per minute, Surface durability, (Unit: kW)							Backlash (Unit: mm)	Catalogue number
400 rpm	800 rpm	1,200 rpm	1,500 rpm	1,800 rpm	2,500 rpm	3,000 rpm	400 rpm	800 rpm	1,200 rpm	1,500 rpm	1,800 rpm	2,500 rpm	3,000 rpm		
4.81	9.62	14.42	18.03	21.48	28.91	34.08	1.03	2.10	3.19	4.02	4.83	6.61	7.87	0.1 to 0.2	<b>SG2.5S 14B – 2515N</b>
5.39	10.78	16.17	20.21	23.93	32.14	37.95	1.19	2.42	3.68	4.65	5.55	7.58	9.04		<b>SG2.5S 15B – 2515N</b>
5.98	11.96	17.94	22.35	26.40	35.46	41.86	1.36	2.77	4.21	5.30	6.32	8.63	10.29		<b>SG2.5S 16B – 2515N</b>
7.19	14.38	21.57	26.60	31.38	42.19	49.72	1.74	3.54	5.39	6.72	7.99	10.94	13.03		<b>SG2.5S 18B – 2515N</b>
8.44	16.88	25.23	30.94	36.42	49.04	57.68	2.16	4.41	6.69	8.30	9.86	13.52	16.07		<b>SG2.5S 20B – 2518N</b>
11.00	22.01	32.39	39.57	46.67	62.66	72.67	3.15	6.44	9.66	11.93	14.22	19.45	22.81		<b>SG2.5S 24B – 2518N</b>
11.66	23.32	34.18	41.73	49.27	65.97	76.34	3.43	7.02	10.48	12.94	15.43	21.07	24.64		<b>SG2.5S 25B – 2520N</b>
13.65	27.30	39.56	48.36	57.05	75.55	87.13	4.34	8.89	13.14	16.26	19.37	26.16	30.51		<b>SG2.5S 28B – 2520N</b>
14.99	29.87	43.11	52.78	62.19	81.77	94.10	5.00	10.23	15.07	18.68	22.24	29.83	34.70		<b>SG2.5S 30B – 2520N</b>
16.34	32.40	46.67	57.20	67.33	87.92	101.35	5.72	11.65	17.13	21.26	25.30	33.69	39.26		<b>SG2.5S 32B – 2520N</b>
18.40	36.19	52.15	63.81	74.84	96.92	112.26	6.89	13.95	20.53	25.44	30.17	39.85	46.65		<b>SG2.5S 35B – 2520N</b>
19.09	37.45	53.97	66.00	77.24	99.87	115.86	7.31	14.76	21.73	26.92	31.84	41.99	49.24		<b>SG2.5S 36B – 2520N</b>
21.87	42.47	61.23	74.71	86.65	112.19	129.97	9.10	18.22	26.86	33.20	38.93	51.40	60.18		<b>SG2.5S 40B – 2525N</b>
25.36	48.64	70.16	84.85	97.96	127.28	146.94	11.63	23.04	34.00	41.67	48.64	64.42	75.14		<b>SG2.5S 45B – 2525N</b>
27.48	52.33	75.48	90.76	104.57	136.13	155.65	13.31	26.19	38.67	47.12	54.88	72.83	84.11		<b>SG2.5S 48B – 2525N</b>
28.90	54.85	79.00	94.63	108.89	141.94	160.97	14.49	28.44	41.94	50.91	59.22	78.68	90.11		<b>SG2.5S 50B – 2525N</b>
32.47	61.12	87.29	104.08	120.17	156.12	173.61	17.69	34.47	50.42	60.92	71.11	94.11	105.66		<b>SG2.5S 55B – 2525N</b>
33.19	62.36	88.91	105.93	122.43	158.43	176.03	18.36	35.74	52.18	63.02	73.62	97.04	108.86		<b>SG2.5S 56B – 2525N</b>
35.94	67.32	95.27	113.22	131.34	167.37	185.40	21.14	41.06	59.51	71.67	84.04	109.06	121.93		<b>SG2.5S 60B – 2525N</b>
38.61	72.24	101.49	120.77	140.07	175.88	-	24.07	46.72	67.25	81.09	95.05	121.50	-		<b>SG2.5S 64B – 2525N</b>
42.59	79.53	110.56	132.11	152.83	187.90	-	28.82	55.88	79.59	96.37	112.64	140.91	-	<b>SG2.5S 70B – 2525N</b>	
43.91	81.94	113.52	135.82	157.00	191.72	-	30.49	59.11	83.90	101.71	118.78	147.57	-	<b>SG2.5S 72B – 2525N</b>	
45.87	85.53	117.88	141.33	163.16	197.29	-	33.09	64.11	90.53	109.96	128.25	157.71	-	<b>SG2.5S 75B – 2525N</b>	
49.13	91.20	125.49	150.35	171.91	-	-	37.64	72.66	102.43	124.31	143.57	-	-	<b>SG2.5S 80B – 2525N</b>	





Unit: mm

Accuracy Class	Material	Pressure angle	Heat treatment	Tooth surface hardness	Backlash ①
[JIS B 1702-1] N5	SCM435/440	20°	Induction hardening of teeth	HRC49 to 55	See the table below

★ No surface treatment is applied.

★ This allowable transfer capability table was prepared by using the formulas presented by the JGMA (Japan Gear Manufacturers Association). For the unit conversion method, refer to P. 20 in "References."

① This is a theoretical value obtained when a pair of gears of the same type and material are meshed with each other.

Catalogue number	Number of teeth	Reference diameter	Tip diameter	Type	Face width	Hole diameter	Hub diameter	Hub length	Overall length	Weight
	$z$	$d$	$d_a$		$b$	$d_a(H7)$	$d_h$	$l_h$	$l$	$W(kg)$
SG3S 14B – 3016N	14	φ 42	φ 48	B1	30	φ 16	φ 34	20	50	0.39
SG3S 15B – 3016N	15	φ 45	φ 51			φ 16	φ 36			0.46
SG3S 16B – 3016N	16	φ 48	φ 54			φ 16	φ 38			0.53
SG3S 18B – 3016N	18	φ 54	φ 60			φ 16	φ 40			0.66
SG3S 20B – 3020N	20	φ 60	φ 66			φ 20	φ 50			0.85
SG3S 24B – 3020N	24	φ 72	φ 78			φ 20	φ 58			1.25
SG3S 25B – 3020N	25	φ 75	φ 81			φ 20	φ 60			1.36
SG3S 28B – 3020N	28	φ 84	φ 90			φ 20	φ 70			1.79
SG3S 30B – 3025N	30	φ 90	φ 96			φ 25	φ 75			2.00
SG3S 32B – 3025N	32	φ 96	φ 102			φ 25	φ 75			2.21
SG3S 35B – 3025N	35	φ 105	φ 111			φ 25	φ 80			2.64
SG3S 36B – 3025N	36	φ 108	φ 114			φ 25	φ 80			2.75
SG3S 40B – 3030	40	φ 120	φ 126			φ 30	φ 70			3.00
SG3S 40B – 3025N	40	φ 120	φ 126			φ 25	φ 80			3.26
SG3S 45B – 3025N	45	φ 135	φ 141			φ 25	φ 80			3.97
SG3S 48B – 3025N	48	φ 144	φ 150			φ 25	φ 85			4.53
SG3S 50B – 3030N	50	φ 150	φ 156			φ 30	φ 85			4.78
SG3S 55B – 3030N	55	φ 165	φ 171			φ 30	φ 90			5.76
SG3S 56B – 3030N	56	φ 168	φ 174			φ 30	φ 90			5.94
SG3S 60B – 3030N	60	φ 180	φ 186			φ 30	φ 100			6.95
SG3S 64B – 3030N	64	φ 192	φ 198	φ 30	φ 100	7.77				
SG3S 70B – 3030N	70	φ 210	φ 216	φ 30	φ 100	9.11				
SG3S 72B – 3030N	72	φ 216	φ 222	φ 30	φ 100	9.59				
SG3S 75B – 3030N	75	φ 225	φ 231	φ 30	φ 100	10.32				
SG3S 80B – 3030N	80	φ 240	φ 246	φ 30	φ 100	11.61				



2D • 3D CAD

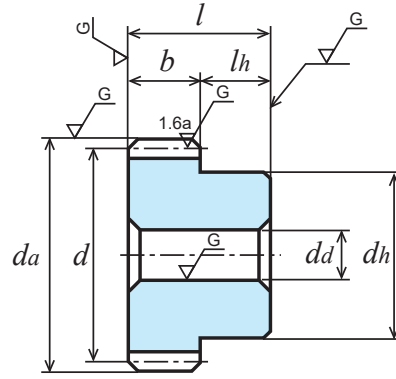

B1 type [-]

Allowable transfer capability table for different revolutions per minute, Bending strength, (Unit: kW)							Allowable transfer capability table for different revolutions per minute, Surface durability, (Unit: kW)							Backlash (Unit: mm)	Catalogue number
400 rpm	800 rpm	1,200 rpm	1,500 rpm	1,800 rpm	2,500 rpm	3,000 rpm	400 rpm	800 rpm	1,200 rpm	1,500 rpm	1,800 rpm	2,500 rpm	3,000 rpm		
8.31	16.62	24.93	30.93	36.51	49.07	57.88	1.81	3.68	5.60	7.02	8.36	11.43	13.62	0.12 to 0.24	<b>SG3S 14B – 3016N</b>
9.31	18.62	27.93	34.46	40.64	54.65	64.40	2.08	4.25	6.47	8.06	9.59	13.13	15.64		<b>SG3S 15B – 3016N</b>
10.33	20.67	30.99	38.02	44.79	60.28	70.95	2.38	4.86	7.40	9.17	10.91	14.95	17.78		<b>SG3S 16B – 3016N</b>
12.42	24.84	36.90	45.18	53.16	71.59	83.78	3.04	6.21	9.38	11.61	13.79	18.92	22.39		<b>SG3S 18B – 3016N</b>
14.59	29.17	42.93	52.45	61.87	83.06	96.33	3.78	7.73	11.59	14.32	17.06	23.34	27.37		<b>SG3S 20B – 3020N</b>
19.01	38.01	54.95	67.21	79.24	104.65	120.57	5.52	11.31	16.68	20.65	24.60	33.13	38.59		<b>SG3S 24B – 3020N</b>
20.15	40.15	57.96	70.95	83.59	109.93	126.49	6.01	12.28	18.09	22.41	26.69	35.79	41.64		<b>SG3S 25B – 3020N</b>
23.59	46.57	67.09	82.15	96.61	125.47	145.00	7.60	15.42	22.69	28.14	33.45	44.30	51.76		<b>SG3S 28B – 3020N</b>
25.90	50.82	73.23	89.55	104.80	135.50	157.19	8.77	17.71	26.08	32.30	38.21	50.39	59.08		<b>SG3S 30B – 3025N</b>
28.24	55.08	79.39	96.95	112.84	145.94	169.26	10.03	20.15	29.69	36.74	43.23	57.01	66.83		<b>SG3S 32B – 3025N</b>
31.79	61.43	88.58	107.77	124.68	161.66	187.02	12.09	24.10	35.54	43.81	51.24	67.75	79.19		<b>SG3S 35B – 3025N</b>
32.98	63.54	91.64	111.22	128.56	166.83	192.84	12.82	25.49	37.60	46.25	54.04	71.51	83.51		<b>SG3S 36B – 3025N</b>
37.79	71.94	103.77	124.77	143.76	187.16	214.00	15.97	31.43	46.40	56.54	65.86	87.40	100.93		<b>SG3S 40B – 3030</b>
37.79	71.94	103.77	124.77	143.76	187.16	214.00	15.97	31.43	46.40	56.54	65.86	87.40	100.93		<b>SG3S 40B – 3025N</b>
43.83	82.62	118.23	141.06	162.71	211.59	236.20	20.43	39.86	58.41	70.63	82.36	109.12	122.99		<b>SG3S 45B – 3025N</b>
47.47	89.00	126.51	150.58	174.29	224.14	248.74	23.37	45.39	66.08	79.71	93.26	122.16	136.84		<b>SG3S 48B – 3025N</b>
49.77	93.24	131.94	156.80	181.90	231.80	256.76	25.37	49.27	71.42	86.01	100.85	130.87	146.32		<b>SG3S 50B – 3030N</b>
55.48	103.74	145.22	173.05	200.54	250.00	-	30.73	59.63	85.52	103.27	120.93	153.45	-		<b>SG3S 55B – 3030N</b>
56.62	105.82	147.83	176.30	204.19	253.49	-	31.86	61.82	88.47	106.92	125.14	158.10	-		<b>SG3S 56B – 3030N</b>
61.14	114.10	158.07	189.13	218.62	266.97	-	36.59	70.93	100.68	122.05	142.54	177.08	-		<b>SG3S 60B – 3030N</b>
65.63	122.26	168.12	201.71	232.50	-	-	41.63	80.62	113.58	138.05	160.74	-	-	<b>SG3S 64B – 3030N</b>	
72.29	133.62	184.00	220.08	249.18	-	-	49.78	95.73	135.04	163.59	187.06	-	-	<b>SG3S 70B – 3030N</b>	
74.50	137.34	189.20	226.08	254.51	-	-	52.66	101.01	142.56	172.51	196.11	-	-	<b>SG3S 72B – 3030N</b>	
77.78	142.85	196.93	234.96	262.28	-	-	57.11	109.17	154.16	186.25	209.93	-	-	<b>SG3S 75B – 3030N</b>	
83.22	151.85	209.58	247.54	274.71	-	-	64.93	123.36	174.37	208.50	233.57	-	-	<b>SG3S 80B – 3030N</b>	



Unit: mm

Accuracy Class	Material	Pressure angle	Heat treatment	Tooth surface hardness	Surface treatment ①	Backlash ②
[JIS B 1702-1] N6	S45C	20°	Induction hardening of teeth	HRC50 to 56	Black oxide finish	See the table below

① A black oxide finish is applied to the gear surface, but not the tooth surfaces.

② This is a theoretical value obtained when a pair of gears of the same type and material are meshed with each other.

★ The allowable transfer capability table was prepared by using the formulas presented by the JGMA (Japan Gear Manufacturers Association). For the unit conversion method, refer to P. 20 in "References."

Catalogue number	Module <i>m</i>	Number of teeth <i>z</i>	Reference diameter <i>d</i>	Tip diameter <i>d<sub>a</sub></i>	Type	Face width <i>b</i>	Hole diameter <i>d<sub>a</sub>(H7)</i>	Hub diameter <i>d<sub>h</sub></i>	Hub length <i>l<sub>h</sub></i>	Overall length <i>l</i>	Weight <i>W(kg)</i>
<b>SGR50S 30B – 0505</b>	0.5	30	φ15	φ16	B1	5	φ 5	φ12	8	13	0.012
<b>SGR50S 40B – 0506</b>		40	φ20	φ21			φ 6	φ15			0.021
<b>SGR50S 50B – 0506</b>		50	φ25	φ26			φ 6	φ18			0.032
<b>SGR50S 60B – 0506</b>		60	φ30	φ31			φ 6	φ22			0.049
<b>SGR50S 70B – 0508</b>		70	φ35	φ36			φ 8	φ25			0.063
<b>SGR50S 80B – 0508</b>		80	φ40	φ41			φ 8	φ28			0.083
<b>SGR50S 90B – 0508</b>		90	φ45	φ46			φ 8	φ32			0.108
<b>SGR50S 100B – 0510</b>		100	φ50	φ51			φ10	φ35			0.129
<b>SGR50S 120B – 0510</b>		120	φ60	φ61			φ10	φ42			0.190
<b>SGR80S 25B – 0805</b>	0.8	25	φ20	φ21.6	B1	8	φ 5	φ16	10	18	0.033
<b>SGR80S 30B – 0805</b>		30	φ24	φ25.6			φ 5	φ20			0.050
<b>SGR80S 40B – 0808</b>		40	φ32	φ33.6			φ 8	φ25			0.082
<b>SGR80S 50B – 0808</b>		50	φ40	φ41.6			φ 8	φ28			0.12
<b>SGR80S 60B – 0808</b>		60	φ48	φ49.6			φ 8	φ28			0.155
<b>SGR80S 70B – 0808</b>		70	φ56	φ57.6			φ 8	φ28			0.196
<b>SGR80S 80B – 0808</b>		80	φ64	φ65.6			φ 8	φ28			0.243
<b>SGR80S 90B – 0810</b>		90	φ72	φ73.6			φ10	φ30			0.300
<b>SGR80S 100B – 0812</b>		100	φ80	φ81.6			φ12	φ40			0.398
<b>SGR80S 120B – 0812</b>		120	φ96	φ97.6			φ12	φ40			0.537



2D • 3D CAD

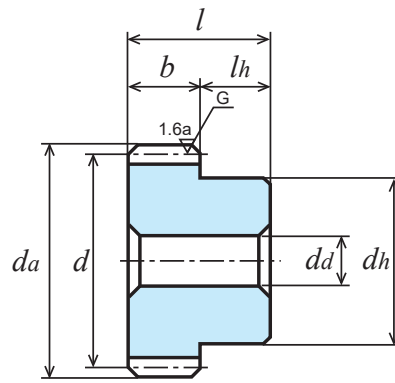

B1 type

Allowable transfer capability table for different revolutions per minute, Bending strength, (Unit: kW)							Allowable transfer capability table for different revolutions per minute, Surface durability, (Unit: kW)							Backlash (Unit: mm)	Catalogue number
400 rpm	800 rpm	1,200 rpm	1,500 rpm	1,800 rpm	2,500 rpm	3,000 rpm	400 rpm	800 rpm	1,200 rpm	1,500 rpm	1,800 rpm	2,500 rpm	3,000 rpm		
0.080	0.161	0.241	0.299	0.355	0.480	0.565	0.023	0.049	0.075	0.093	0.112	0.154	0.183	0.02 to 0.08	<b>SGR50S 30B – 0505</b>
0.117	0.234	0.346	0.427	0.504	0.677	0.795	0.043	0.089	0.135	0.168	0.200	0.272	0.323		<b>SGR50S 40B – 0506</b>
0.154	0.308	0.450	0.552	0.651	0.872	1.031	0.069	0.142	0.212	0.263	0.313	0.425	0.507		<b>SGR50S 50B – 0506</b>
0.192	0.380	0.553	0.676	0.793	1.071	1.263	0.101	0.207	0.307	0.379	0.448	0.614	0.730		<b>SGR50S 60B – 0506</b>
0.230	0.451	0.653	0.796	0.938	1.266	1.495	0.140	0.283	0.417	0.514	0.610	0.836	0.995		<b>SGR50S 70B – 0508</b>
0.269	0.521	0.751	0.916	1.083	1.460	1.725	0.186	0.371	0.544	0.670	0.799	1.092	1.301		<b>SGR50S 80B – 0508</b>
0.308	0.590	0.846	1.037	1.225	1.652	1.950	0.238	0.470	0.687	0.850	1.012	1.385	1.647		<b>SGR50S 90B – 0508</b>
0.346	0.658	0.943	1.158	1.366	1.844	2.173	0.296	0.580	0.847	1.051	1.249	1.711	2.032		<b>SGR50S 100B – 0510</b>
0.419	0.790	1.139	1.395	1.648	2.219	2.580	0.429	0.834	1.224	1.513	1.802	2.461	2.886		<b>SGR50S 120B – 0510</b>
0.257	0.500	0.761	0.937	1.108	1.487	1.748	0.069	0.144	0.216	0.269	0.320	0.436	0.517		<b>SGR80S 25B – 0805</b>
0.329	0.659	0.964	1.184	1.396	1.867	2.210	0.102	0.210	0.313	0.388	0.461	0.626	0.747	<b>SGR80S 30B – 0805</b>	
0.479	0.943	1.369	1.672	1.961	2.653	3.127	0.186	0.378	0.559	0.689	0.815	1.118	1.328	<b>SGR80S 40B – 0808</b>	
0.632	1.224	1.764	2.150	2.544	3.427	4.051	0.297	0.593	0.871	1.072	1.279	1.747	2.083	<b>SGR80S 50B – 0808</b>	
0.788	1.501	2.149	2.641	3.117	4.207	4.960	0.436	0.856	1.248	1.549	1.843	2.523	2.998	<b>SGR80S 60B – 0808</b>	
0.937	1.772	2.549	3.125	3.686	4.972	5.814	0.597	1.164	1.704	2.110	2.509	3.433	4.047	<b>SGR80S 70B – 0808</b>	
1.085	2.037	2.943	3.599	4.257	5.706	6.618	0.783	1.516	2.229	2.753	3.283	4.464	5.219	<b>SGR80S 80B – 0808</b>	
1.230	2.293	3.326	4.076	4.813	6.383	7.378	0.995	1.911	2.822	3.492	4.157	5.593	6.517	<b>SGR80S 90B – 0810</b>	
1.374	2.563	3.706	4.550	5.364	7.040	8.082	1.230	2.366	3.481	4.316	5.129	6.830	7.903	<b>SGR80S 100B – 0812</b>	
1.657	3.094	4.476	5.477	6.391	8.252	9.311	1.774	3.415	5.028	6.213	7.308	9.573	10.888	<b>SGR80S 120B – 0812</b>	



Unit: mm

Accuracy Class	Material	Pressure angle	Heat treatment	Tooth surface hardness	Surface treatment ①	Backlash ②
[JIS B 1702-1] N6	S45C	20°	Induction hardening of teeth	HRC50 to 56	Black oxide finish	See the table below

① A black oxide finish is applied to the gear surface, but not the tooth surfaces.

② This is a theoretical value obtained when a pair of gears of the same type and material are meshed with each other.

★ The allowable transfer capability table was prepared by using the formulas presented by the JGMA (Japan Gear Manufacturers Association). For the unit conversion method, refer to P. 20 in "References."

Catalogue number	Number of teeth	Reference diameter	Tip diameter	Type	Face width	Hole diameter	Hub diameter	Hub length	Overall length	Weight
	$z$	$d$	$d_a$		$b$	$d_a(H7)$	$d_h$	$l_h$	$l$	$W(kg)$
SGR1S 14B – 1005	14	φ 14	φ 16	B1	10	φ 5	φ 11	10	20	0.016
SGR1S 15B – 1006	15	φ 15	φ 17			φ 6	φ 12			0.018
SGR1S 16B – 1006	16	φ 16	φ 18			φ 6	φ 13			0.022
SGR1S 17B – 1006	17	φ 17	φ 19			φ 6	φ 14			0.025
SGR1S 18B – 1006	18	φ 18	φ 20			φ 6	φ 15			0.029
SGR1S 19B – 1006	19	φ 19	φ 21			φ 6	φ 16			0.034
SGR1S 20B – 1006	20	φ 20	φ 22			φ 6	φ 16			0.036
SGR1S 21B – 1008	21	φ 21	φ 23			φ 8	φ 18			0.039
SGR1S 22B – 1008	22	φ 22	φ 24			φ 8	φ 18			0.042
SGR1S 23B – 1008	23	φ 23	φ 25			φ 8	φ 20			0.049
SGR1S 24B – 1008	24	φ 24	φ 26			φ 8	φ 20			0.052
SGR1S 25B – 1008	25	φ 25	φ 27			φ 8	φ 20			0.055
SGR1S 26B – 1008	26	φ 26	φ 28			φ 8	φ 20			0.058
SGR1S 27B – 1008	27	φ 27	φ 29			φ 8	φ 20			0.062
SGR1S 28B – 1008	28	φ 28	φ 30			φ 8	φ 20			0.065
SGR1S 29B – 1008	29	φ 29	φ 31			φ 8	φ 25			0.082
SGR1S 30B – 1010	30	φ 30	φ 32			φ 10	φ 25			0.082
SGR1S 32B – 1010	32	φ 32	φ 34			φ 10	φ 25			0.089
SGR1S 34B – 1010	34	φ 34	φ 36			φ 10	φ 25			0.097
SGR1S 35B – 1010	35	φ 35	φ 37			φ 10	φ 25			0.102
SGR1S 36B – 1010	36	φ 36	φ 38			φ 10	φ 25			0.106
SGR1S 38B – 1010	38	φ 38	φ 40			φ 10	φ 30			0.132
SGR1S 40B – 1010	40	φ 40	φ 42			φ 10	φ 30			0.142
SGR1S 42B – 1010	42	φ 42	φ 44			φ 10	φ 30			0.152
SGR1S 44B – 1010	44	φ 44	φ 46	φ 10	φ 30	0.163				
SGR1S 45B – 1010	45	φ 45	φ 47	φ 10	φ 30	0.168				
SGR1S 48B – 1010	48	φ 48	φ 50	φ 10	φ 30	0.185				
SGR1S 50B – 1012	50	φ 50	φ 52	φ 12	φ 35	0.212				
SGR1S 55B – 1012	55	φ 55	φ 57	φ 12	φ 35	0.244				
SGR1S 56B – 1012	56	φ 56	φ 58	φ 12	φ 35	0.251				
SGR1S 60B – 1012	60	φ 60	φ 62	φ 12	φ 40	0.303				
SGR1S 64B – 1012	64	φ 64	φ 66	φ 12	φ 40	0.333				
SGR1S 70B – 1012	70	φ 70	φ 72	φ 12	φ 40	0.383				
SGR1S 75B – 1012	75	φ 75	φ 77	φ 12	φ 40	0.428				
SGR1S 80B – 1015	80	φ 80	φ 82	φ 15	φ 50	0.520				
SGR1S 90B – 1015	90	φ 90	φ 92	φ 15	φ 50	0.626				
SGR1S 100B – 1015	100	φ 100	φ 102	φ 15	φ 50	0.743				
SGR1S 120B – 1015	120	φ 120	φ 122	φ 15	φ 50	1.014				

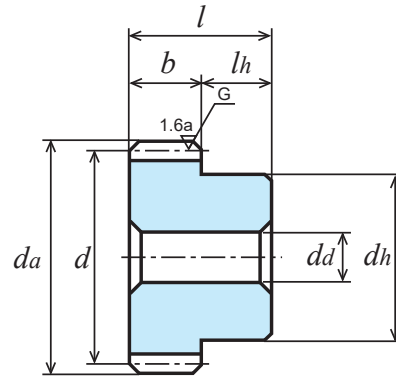

B1 type

Allowable transfer capability table for different revolutions per minute, Bending strength, (Unit: kW)							Allowable transfer capability table for different revolutions per minute, Surface durability, (Unit: kW)							Backlash (Unit: mm)	Catalogue number
400 rpm	800 rpm	1,200 rpm	1,500 rpm	1,800 rpm	2,500 rpm	3,000 rpm	400 rpm	800 rpm	1,200 rpm	1,500 rpm	1,800 rpm	2,500 rpm	3,000 rpm		
0.21	0.41	0.62	0.77	0.91	1.23	1.45	0.04	0.09	0.13	0.16	0.20	0.27	0.32	0.08 to 0.16	<b>SGR1S 14B – 1005</b>
0.23	0.47	0.70	0.87	1.03	1.39	1.64	0.05	0.10	0.15	0.19	0.22	0.31	0.37		<b>SGR1S 15B – 1006</b>
0.26	0.52	0.78	0.96	1.14	1.54	1.81	0.05	0.11	0.17	0.21	0.26	0.35	0.42		<b>SGR1S 16B – 1006</b>
0.29	0.57	0.85	1.05	1.25	1.68	1.98	0.06	0.13	0.19	0.24	0.29	0.40	0.47		<b>SGR1S 17B – 1006</b>
0.31	0.62	0.93	1.15	1.36	1.82	2.14	0.07	0.14	0.22	0.27	0.32	0.44	0.52		<b>SGR1S 18B – 1006</b>
0.34	0.68	1.01	1.24	1.46	1.97	2.31	0.08	0.16	0.24	0.30	0.36	0.49	0.58		<b>SGR1S 19B – 1006</b>
0.37	0.73	1.08	1.33	1.57	2.11	2.48	0.09	0.18	0.27	0.34	0.40	0.55	0.65		<b>SGR1S 20B – 1006</b>
0.39	0.78	1.16	1.42	1.68	2.25	2.66	0.10	0.20	0.30	0.37	0.44	0.60	0.71		<b>SGR1S 21B – 1008</b>
0.42	0.84	1.23	1.52	1.79	2.40	2.83	0.11	0.22	0.33	0.41	0.49	0.66	0.78		<b>SGR1S 22B – 1008</b>
0.45	0.89	1.31	1.61	1.90	2.54	3.00	0.12	0.24	0.36	0.45	0.53	0.72	0.86		<b>SGR1S 23B – 1008</b>
0.47	0.95	1.39	1.70	2.01	2.69	3.18	0.13	0.26	0.39	0.49	0.58	0.78	0.93		<b>SGR1S 24B – 1008</b>
0.50	1.00	1.47	1.80	2.12	2.84	3.35	0.14	0.29	0.43	0.53	0.63	0.85	1.01		<b>SGR1S 25B – 1008</b>
0.53	1.06	1.54	1.89	2.23	2.99	3.53	0.15	0.31	0.46	0.57	0.68	0.92	1.10		<b>SGR1S 26B – 1008</b>
0.56	1.11	1.62	1.98	2.33	3.14	3.71	0.16	0.33	0.50	0.61	0.73	0.99	1.18		<b>SGR1S 27B – 1008</b>
0.59	1.16	1.70	2.08	2.44	3.29	3.88	0.18	0.36	0.53	0.66	0.78	1.07	1.27		<b>SGR1S 28B – 1008</b>
0.62	1.22	1.77	2.17	2.55	3.43	4.05	0.19	0.39	0.57	0.71	0.84	1.15	1.37		<b>SGR1S 29B – 1008</b>
0.64	1.27	1.85	2.26	2.66	3.58	4.23	0.20	0.41	0.61	0.76	0.90	1.23	1.46		<b>SGR1S 30B – 1010</b>
0.70	1.38	2.00	2.45	2.87	3.88	4.58	0.23	0.47	0.70	0.86	1.02	1.40	1.66		<b>SGR1S 32B – 1010</b>
0.76	1.49	2.16	2.63	3.10	4.18	4.93	0.26	0.53	0.79	0.97	1.15	1.58	1.88		<b>SGR1S 34B – 1010</b>
0.79	1.54	2.23	2.72	3.21	4.33	5.11	0.28	0.57	0.84	1.03	1.22	1.67	1.99		<b>SGR1S 35B – 1010</b>
0.82	1.60	2.31	2.81	3.32	4.48	5.29	0.30	0.60	0.88	1.09	1.29	1.77	2.11	<b>SGR1S 36B – 1010</b>	
0.88	1.70	2.46	2.99	3.54	4.77	5.64	0.33	0.67	0.98	1.21	1.44	1.97	2.35	<b>SGR1S 38B – 1010</b>	
0.94	1.81	2.61	3.18	3.77	5.07	6.00	0.37	0.74	1.09	1.34	1.60	2.18	2.60	<b>SGR1S 40B – 1010</b>	
1.00	1.92	2.76	3.37	3.99	5.37	6.35	0.41	0.82	1.20	1.48	1.76	2.41	2.87	<b>SGR1S 42B – 1010</b>	
1.06	2.03	2.91	3.56	4.21	5.67	6.70	0.45	0.90	1.32	1.63	1.94	2.65	3.15	<b>SGR1S 44B – 1010</b>	
1.09	2.08	2.98	3.66	4.32	5.82	6.87	0.48	0.94	1.37	1.70	2.02	2.77	3.30	<b>SGR1S 45B – 1010</b>	
1.18	2.24	3.21	3.94	4.65	6.27	7.40	0.55	1.07	1.56	1.94	2.30	3.15	3.75	<b>SGR1S 48B – 1010</b>	
1.23	2.34	3.36	4.13	4.87	6.57	7.74	0.59	1.16	1.70	2.10	2.50	3.42	4.06	<b>SGR1S 50B – 1012</b>	
1.38	2.61	3.75	4.59	5.42	7.31	8.56	0.72	1.40	2.05	2.54	3.02	4.14	4.89	0.1 to 0.18	<b>SGR1S 55B – 1012</b>
1.41	2.66	3.82	4.69	5.53	7.45	8.72	0.75	1.46	2.13	2.64	3.14	4.29	5.06		<b>SGR1S 56B – 1012</b>
1.52	2.86	4.13	5.05	5.97	8.04	9.35	0.86	1.67	2.45	3.03	3.60	4.92	5.77		<b>SGR1S 60B – 1012</b>
1.63	3.07	4.43	5.42	6.41	8.59	9.97	0.98	1.90	2.79	3.44	4.10	5.58	6.52		<b>SGR1S 64B – 1012</b>
1.81	3.37	4.88	5.98	7.06	9.39	10.87	1.18	2.26	3.34	4.13	4.91	6.63	7.73		<b>SGR1S 70B – 1012</b>
1.95	3.63	5.25	6.44	7.60	10.05	11.60	1.35	2.60	3.83	4.74	5.64	7.56	8.79		<b>SGR1S 75B – 1012</b>
2.09	3.89	5.62	6.90	8.14	10.68	12.26	1.54	2.96	4.35	5.40	6.41	8.54	9.88		<b>SGR1S 80B – 1015</b>
2.36	4.40	6.37	7.80	9.15	11.90	13.48	1.95	3.75	5.52	6.83	8.07	10.65	12.16		<b>SGR1S 90B – 1015</b>
2.63	4.91	7.11	8.69	10.11	12.98	14.62	2.41	4.63	6.82	8.42	9.88	12.87	14.61		<b>SGR1S 100B – 1015</b>
3.16	5.91	8.56	10.32	11.93	14.93	17.01	3.46	6.67	9.82	11.96	13.94	17.69	20.32		0.12 to 0.20



Unit: mm

Accuracy Class	Material	Pressure angle	Heat treatment	Tooth surface hardness	Surface treatment ①	Backlash ②
[JIS B 1702-1] N6	S45C	20°	Induction hardening of teeth	HRC50 to 56	Black oxide finish	See the table below

① A black oxide finish is applied to the gear surface, but not the tooth surfaces.

② This is a theoretical value obtained when a pair of gears of the same type and material are meshed with each other.

★ The allowable transfer capability table was prepared by using the formulas presented by the JGMA (Japan Gear Manufacturers Association). For the unit conversion method, refer to P. 20 in "References."

Catalogue number	Number of teeth	Reference diameter	Tip diameter	Type	Face width	Hole diameter	Hub diameter	Hub length	Overall length	Weight
	<i>z</i>	<i>d</i>	<i>d<sub>a</sub></i>			<i>d<sub>a</sub>(H7)</i>	<i>d<sub>h</sub></i>	<i>l<sub>h</sub></i>		
<b>SGR1.5S 14B – 1510</b>	14	φ 21	φ 24	B1	15	φ 10	φ 17	14	29	0.05
<b>SGR1.5S 15B – 1510</b>	15	φ 22.5	φ 25.5			φ 10	φ 18			0.06
<b>SGR1.5S 16B – 1510</b>	16	φ 24	φ 27			φ 10	φ 20			0.07
<b>SGR1.5S 17B – 1510</b>	17	φ 25.5	φ 28.5			φ 10	φ 21			0.08
<b>SGR1.5S 18B – 1510</b>	18	φ 27	φ 30			φ 10	φ 22			0.09
<b>SGR1.5S 19B – 1510</b>	19	φ 28.5	φ 31.5			φ 10	φ 23			0.10
<b>SGR1.5S 20B – 1510</b>	20	φ 30	φ 33			φ 10	φ 24			0.12
<b>SGR1.5S 21B – 1510</b>	21	φ 31.5	φ 34.5			φ 10	φ 25			0.13
<b>SGR1.5S 22B – 1512</b>	22	φ 33	φ 36			φ 12	φ 26			0.13
<b>SGR1.5S 23B – 1512</b>	23	φ 34.5	φ 37.5			φ 12	φ 27			0.15
<b>SGR1.5S 24B – 1512</b>	24	φ 36	φ 39			φ 12	φ 28			0.16
<b>SGR1.5S 25B – 1512</b>	25	φ 37.5	φ 40.5			φ 12	φ 30			0.18
<b>SGR1.5S 26B – 1512</b>	26	φ 39	φ 42			φ 12	φ 32			0.20
<b>SGR1.5S 27B – 1515</b>	27	φ 40.5	φ 43.5			φ 15	φ 34			0.21
<b>SGR1.5S 28B – 1515</b>	28	φ 42	φ 45			φ 15	φ 36			0.23
<b>SGR1.5S 29B – 1515</b>	29	φ 43.5	φ 46.5			φ 15	φ 37			0.25
<b>SGR1.5S 30B – 1515</b>	30	φ 45	φ 48			φ 15	φ 38			0.27
<b>SGR1.5S 32B – 1515</b>	32	φ 48	φ 51			φ 15	φ 40			0.31
<b>SGR1.5S 34B – 1515</b>	34	φ 51	φ 54			φ 15	φ 42			0.35
<b>SGR1.5S 35B – 1515</b>	35	φ 52.5	φ 55.5			φ 15	φ 42			0.37
<b>SGR1.5S 36B – 1515</b>	36	φ 54	φ 57			φ 15	φ 45			0.40
<b>SGR1.5S 38B – 1515</b>	38	φ 57	φ 60			φ 15	φ 45			0.44
<b>SGR1.5S 40B – 1515</b>	40	φ 60	φ 63			φ 15	φ 50			0.51
<b>SGR1.5S 42B – 1515</b>	42	φ 63	φ 66			φ 15	φ 50			0.54
<b>SGR1.5S 44B – 1515</b>	44	φ 66	φ 69			φ 15	φ 50			0.58
<b>SGR1.5S 45B – 1518</b>	45	φ 67.5	φ 70.5			φ 18	φ 50			0.58
<b>SGR1.5S 48B – 1518</b>	48	φ 72	φ 75			φ 18	φ 50			0.64
<b>SGR1.5S 50B – 1518</b>	50	φ 75	φ 78			φ 18	φ 60			0.77
<b>SGR1.5S 55B – 1518</b>	55	φ 82.5	φ 85.5			φ 18	φ 60			0.88
<b>SGR1.5S 56B – 1518</b>	56	φ 84	φ 87			φ 18	φ 60			0.91
<b>SGR1.5S 60B – 1520</b>	60	φ 90	φ 93	φ 20	φ 60	0.99				
<b>SGR1.5S 64B – 1520</b>	64	φ 96	φ 99	φ 20	φ 60	1.09				
<b>SGR1.5S 70B – 1520</b>	70	φ 105	φ 108	φ 20	φ 60	1.26				
<b>SGR1.5S 75B – 1520</b>	75	φ 112.5	φ 115.5	φ 20	φ 60	1.41				
<b>SGR1.5S 80B – 1520</b>	80	φ 120	φ 123	φ 20	φ 70	1.68				
<b>SGR1.5S 90B – 1520</b>	90	φ 135	φ 138	φ 20	φ 70	2.04				
<b>SGR1.5S 100B – 1520</b>	100	φ 150	φ 153	φ 20	φ 70	2.43				



2D • 3D CAD

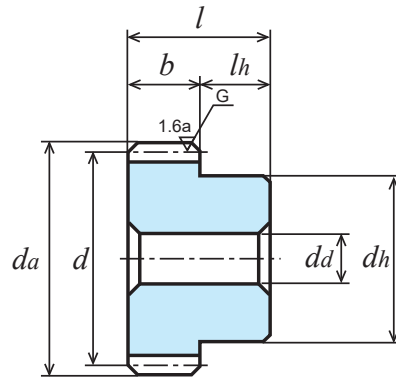

B1 type

Allowable transfer capability table for different revolutions per minute, Bending strength, (Unit: kW)							Allowable transfer capability table for different revolutions per minute, Surface durability, (Unit: kW)							Backlash (Unit: mm)	Catalogue number
400 rpm	800 rpm	1,200 rpm	1,500 rpm	1,800 rpm	2,500 rpm	3,000 rpm	400 rpm	800 rpm	1,200 rpm	1,500 rpm	1,800 rpm	2,500 rpm	3,000 rpm		
0.69	1.39	2.05	2.52	2.98	3.99	4.70	0.14	0.30	0.45	0.56	0.66	0.90	1.07	0.08 to 0.16	SGR1.5S 14B – 1510
0.79	1.57	2.31	2.84	3.35	4.48	5.30	0.17	0.34	0.52	0.64	0.76	1.03	1.23		SGR1.5S 15B – 1510
0.88	1.75	2.57	3.15	3.71	4.97	5.88	0.19	0.39	0.59	0.73	0.87	1.18	1.40		SGR1.5S 16B – 1510
0.96	1.92	2.81	3.44	4.05	5.43	6.42	0.22	0.45	0.66	0.82	0.98	1.33	1.58		SGR1.5S 17B – 1510
1.05	2.09	3.05	3.74	4.39	5.90	6.98	0.25	0.50	0.75	0.92	1.09	1.49	1.78		SGR1.5S 18B – 1510
1.14	2.26	3.30	4.03	4.74	6.38	7.53	0.27	0.56	0.83	1.03	1.22	1.66	1.98		SGR1.5S 19B – 1510
1.23	2.43	3.54	4.33	5.08	6.86	8.09	0.31	0.62	0.92	1.14	1.35	1.84	2.19		SGR1.5S 20B – 1510
1.32	2.60	3.78	4.62	5.42	7.33	8.64	0.34	0.69	1.02	1.25	1.48	2.03	2.41		SGR1.5S 21B – 1510
1.42	2.78	4.03	4.92	5.78	7.81	9.21	0.37	0.75	1.12	1.37	1.63	2.23	2.65		SGR1.5S 22B – 1512
1.51	2.95	4.27	5.21	6.13	8.28	9.77	0.41	0.83	1.22	1.50	1.78	2.44	2.90		SGR1.5S 23B – 1512
1.60	3.12	4.52	5.50	6.49	8.76	10.35	0.45	0.90	1.33	1.63	1.94	2.65	3.16		SGR1.5S 24B – 1512
1.70	3.30	4.76	5.79	6.85	9.23	10.92	0.49	0.98	1.44	1.77	2.11	2.88	3.43		SGR1.5S 25B – 1512
1.79	3.47	5.01	6.09	7.21	9.72	11.49	0.53	1.06	1.55	1.91	2.28	3.11	3.71		SGR1.5S 26B – 1512
1.89	3.64	5.25	6.40	7.57	10.20	12.06	0.57	1.14	1.67	2.06	2.46	3.36	4.00		SGR1.5S 27B – 1515
1.98	3.82	5.50	6.71	7.93	10.69	12.63	0.62	1.23	1.80	2.22	2.65	3.62	4.31		SGR1.5S 28B – 1515
2.08	3.99	5.73	7.02	8.29	11.18	13.20	0.67	1.32	1.93	2.38	2.84	3.88	4.62		SGR1.5S 29B – 1515
2.17	4.16	5.98	7.32	8.65	11.67	13.77	0.71	1.41	2.06	2.55	3.04	4.16	4.94	SGR1.5S 30B – 1515	
2.37	4.51	6.46	7.94	9.37	12.64	14.90	0.82	1.61	2.34	2.90	3.46	4.73	5.62	SGR1.5S 32B – 1515	
2.56	4.85	6.96	8.55	10.08	13.61	16.03	0.93	1.81	2.65	3.28	3.90	5.34	6.34	0.10 to 0.18	SGR1.5S 34B – 1515
2.65	5.03	7.22	8.86	10.44	14.10	16.57	0.98	1.92	2.81	3.48	4.14	5.66	6.71		SGR1.5S 35B – 1515
2.75	5.20	7.47	9.16	10.80	14.58	17.10	1.04	2.03	2.97	3.68	4.37	5.99	7.08		SGR1.5S 36B – 1515
2.93	5.54	7.97	9.77	11.53	15.54	18.15	1.16	2.26	3.31	4.10	4.88	6.67	7.85		SGR1.5S 38B – 1515
3.12	5.88	8.48	10.38	12.26	16.50	19.19	1.29	2.50	3.67	4.54	5.41	7.39	8.66		SGR1.5S 40B – 1515
3.31	6.21	8.97	10.97	12.98	17.42	20.21	1.42	2.76	4.05	5.00	5.96	8.12	9.50		SGR1.5S 42B – 1515
3.50	6.55	9.47	11.59	13.70	18.31	21.22	1.56	3.02	4.45	5.49	6.55	8.88	10.37		SGR1.5S 44B – 1515
3.59	6.71	9.72	11.89	14.06	18.75	21.72	1.64	3.16	4.65	5.75	6.85	9.27	10.82		SGR1.5S 45B – 1518
3.87	7.21	10.46	12.82	15.13	20.07	23.20	1.87	3.58	5.29	6.55	7.80	10.49	12.22		SGR1.5S 48B – 1518
4.06	7.56	10.95	13.43	15.85	20.93	24.17	2.03	3.89	5.74	7.11	8.46	11.33	13.19		SGR1.5S 50B – 1518
4.52	8.43	12.18	14.95	17.62	23.05	26.37	2.46	4.72	6.95	8.61	10.23	13.57	15.65		SGR1.5S 55B – 1518
4.61	8.60	12.43	15.25	17.97	23.46	26.79	2.55	4.90	7.21	8.92	10.60	14.04	16.16		SGR1.5S 56B – 1518
4.98	9.29	13.43	16.46	19.30	25.10	28.43	2.92	5.62	8.28	10.24	12.11	15.98	18.24	SGR1.5S 60B – 1520	
5.34	9.97	14.42	17.65	20.59	26.59	30.00	3.33	6.40	9.43	11.65	13.70	17.95	20.42	SGR1.5S 64B – 1520	
5.88	10.99	15.90	19.38	22.49	28.69	32.25	3.98	7.66	11.28	13.90	16.25	21.03	23.83	0.12 to 0.20	SGR1.5S 70B – 1520
6.33	11.82	17.11	20.75	24.03	30.36	34.03	4.56	8.79	12.95	15.86	18.52	23.73	26.81		SGR1.5S 75B – 1520
6.77	12.65	18.31	22.09	25.54	31.95	36.39	5.19	10.00	14.73	17.94	20.91	26.54	30.47		SGR1.5S 80B – 1520
7.62	14.33	20.59	24.66	28.27	34.91	41.59	6.54	12.68	18.55	22.43	25.92	32.48	39.00		SGR1.5S 90B – 1520
8.49	16.00	22.75	27.14	30.74	39.04	46.85	8.07	15.67	22.69	27.33	31.21	40.21	48.63		SGR1.5S 100B – 1520





Unit: mm

Accuracy Class	Material	Pressure angle	Heat treatment	Tooth surface hardness	Surface treatment ①	Backlash ②
[JIS B 1702-1] N6	S45C	20°	Induction hardening of teeth	HRC50 to 56	Black oxide finish	See the table below

① A black oxide finish is applied to the gear surface, but not the tooth surfaces.

② This is a theoretical value obtained when a pair of gears of the same type and material are meshed with each other.

★ The allowable transfer capability table was prepared by using the formulas presented by the JGMA (Japan Gear Manufacturers Association). For the unit conversion method, refer to P. 20 in "References."

Catalogue number	Number of teeth	Reference diameter	Tip diameter	Type	Face width	Hole diameter	Hub diameter	Hub length	Overall length	Weight
	$z$	$d$	$d_a$		$b$	$d_a(H7)$	$d_h$	$l_h$	$l$	$W(kg)$
SGR2S 14B – 2012	14	φ 28	φ 32	B1	20	φ 12	φ 22	16	36	0.11
SGR2S 15B – 2012	15	φ 30	φ 34			φ 12	φ 24			0.14
SGR2S 16B – 2012	16	φ 32	φ 36			φ 12	φ 26			0.16
SGR2S 17B – 2012	17	φ 34	φ 38			φ 12	φ 28			0.19
SGR2S 18B – 2012	18	φ 36	φ 40			φ 12	φ 30			0.22
SGR2S 19B – 2012	19	φ 38	φ 42			φ 12	φ 31			0.24
SGR2S 20B – 2015	20	φ 40	φ 44			φ 15	φ 32			0.25
SGR2S 21B – 2015	21	φ 42	φ 46			φ 15	φ 34			0.28
SGR2S 22B – 2015	22	φ 44	φ 48			φ 15	φ 36			0.32
SGR2S 23B – 2015	23	φ 46	φ 50			φ 15	φ 37			0.35
SGR2S 24B – 2015	24	φ 48	φ 52			φ 15	φ 38			0.38
SGR2S 25B – 2015	25	φ 50	φ 54			φ 15	φ 40			0.42
SGR2S 26B – 2015	26	φ 52	φ 56			φ 15	φ 42			0.46
SGR2S 27B – 2015	27	φ 54	φ 58			φ 15	φ 44			0.50
SGR2S 28B – 2015	28	φ 56	φ 60			φ 15	φ 45			0.54
SGR2S 29B – 2015	29	φ 58	φ 62			φ 15	φ 48			0.59
SGR2S 30B – 2018	30	φ 60	φ 64			φ 18	φ 50			0.62
SGR2S 32B – 2018	32	φ 64	φ 68			φ 18	φ 50			0.68
SGR2S 34B – 2018	34	φ 68	φ 72			φ 18	φ 50			0.74
SGR2S 35B – 2018	35	φ 70	φ 74			φ 18	φ 50			0.78
SGR2S 36B – 2018	36	φ 72	φ 76			φ 18	φ 50			0.81
SGR2S 38B – 2018	38	φ 76	φ 80			φ 18	φ 50			0.89
SGR2S 40B – 2020	40	φ 80	φ 84			φ 20	φ 60			1.06
SGR2S 42B – 2020	42	φ 84	φ 88			φ 20	φ 60			1.14
SGR2S 44B – 2020	44	φ 88	φ 92			φ 20	φ 60			1.22
SGR2S 45B – 2020	45	φ 90	φ 94			φ 20	φ 60			1.27
SGR2S 48B – 2020	48	φ 96	φ 100			φ 20	φ 60			1.40
SGR2S 50B – 2025	50	φ 100	φ 104			φ 25	φ 60			1.45
SGR2S 55B – 2025	55	φ 110	φ 114			φ 25	φ 60			1.71
SGR2S 56B – 2025	56	φ 112	φ 116			φ 25	φ 60			1.76
SGR2S 60B – 2025	60	φ 120	φ 124	φ 25	φ 65	2.05				
SGR2S 64B – 2025	64	φ 128	φ 132	φ 25	φ 65	2.30				
SGR2S 70B – 2025	70	φ 140	φ 144	φ 25	φ 70	2.76				
SGR2S 72B – 2025	72	φ 144	φ 148	φ 25	φ 70	2.90				
SGR2S 75B – 2025	75	φ 150	φ 154	φ 25	φ 70	3.12				
SGR2S 80B – 2025	80	φ 160	φ 164	φ 25	φ 80	3.65				
SGR2S 90B – 2025	90	φ 180	φ 184	φ 25	φ 80	4.49				
SGR2S 100B – 2025	100	φ 200	φ 204	φ 25	φ 80	5.42				



2D • 3D CAD

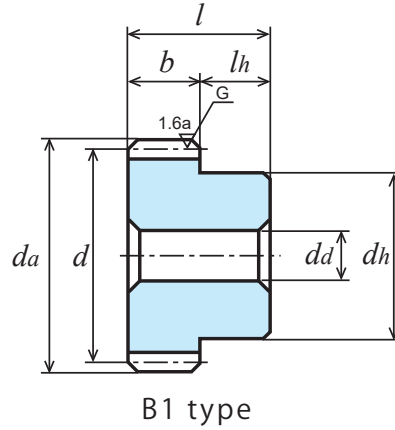

Allowable transfer capability table for different revolutions per minute, Bending strength, (Unit: kW)							Allowable transfer capability table for different revolutions per minute, Surface durability, (Unit: kW)							Backlash (Unit: mm)	Catalogue number
400 rpm	800 rpm	1,200 rpm	1,500 rpm	1,800 rpm	2,500 rpm	3,000 rpm	400 rpm	800 rpm	1,200 rpm	1,500 rpm	1,800 rpm	2,500 rpm	3,000 rpm		
1.64	3.26	4.75	5.82	6.84	9.20	10.86	0.35	0.72	1.07	1.32	1.57	2.14	2.55	0.10 to 0.20	<b>SGR2S 14B – 2012</b>
1.86	3.68	5.35	6.54	7.68	10.37	12.23	0.41	0.83	1.23	1.52	1.79	2.46	2.92		<b>SGR2S 15B – 2012</b>
2.08	4.09	5.94	7.25	8.50	11.50	13.55	0.47	0.95	1.40	1.72	2.04	2.80	3.32		<b>SGR2S 16B – 2012</b>
2.28	4.47	6.49	7.91	9.30	12.57	14.83	0.53	1.07	1.58	1.94	2.30	3.16	3.75		<b>SGR2S 17B – 2012</b>
2.49	4.86	7.04	8.57	10.11	13.64	16.11	0.60	1.20	1.77	2.17	2.59	3.54	4.21		<b>SGR2S 18B – 2012</b>
2.71	5.26	7.59	9.23	10.93	14.72	17.41	0.67	1.34	1.97	2.42	2.88	3.94	4.70		<b>SGR2S 19B – 2012</b>
2.92	5.65	8.15	9.93	11.74	15.82	18.70	0.74	1.48	2.18	2.68	3.20	4.37	5.21		<b>SGR2S 20B – 2015</b>
3.14	6.04	8.70	10.62	12.56	16.92	19.99	0.82	1.64	2.40	2.96	3.53	4.82	5.74		<b>SGR2S 21B – 2015</b>
3.35	6.44	9.25	11.32	13.38	18.03	21.29	0.91	1.80	2.63	3.25	3.87	5.30	6.30		<b>SGR2S 22B – 2015</b>
3.57	6.83	9.80	12.02	14.19	19.14	22.58	1.00	1.97	2.87	3.56	4.23	5.79	6.89		<b>SGR2S 23B – 2015</b>
3.79	7.23	10.35	12.72	15.01	20.32	23.88	1.09	2.14	3.12	3.87	4.61	6.31	7.50	<b>SGR2S 24B – 2015</b>	
4.01	7.62	10.93	13.42	15.83	21.36	25.17	1.19	2.32	3.39	4.20	5.00	6.85	9.03	<b>SGR2S 25B – 2015</b>	
4.23	8.02	11.50	14.12	16.64	22.48	26.43	1.28	2.51	3.67	4.55	5.40	7.40	8.78	0.12 to 0.22	<b>SGR2S 26B – 2015</b>
4.44	8.41	12.08	14.82	17.47	23.59	27.66	1.39	2.71	3.96	4.91	5.83	7.98	9.44		<b>SGR2S 27B – 2015</b>
4.66	8.80	12.66	15.52	18.31	24.70	28.88	1.49	2.91	4.26	5.28	6.27	8.58	10.12		<b>SGR2S 28B – 2015</b>
4.87	9.19	13.24	16.21	19.14	25.79	30.08	1.60	3.12	4.57	5.66	6.73	9.21	10.82		<b>SGR2S 29B – 2015</b>
5.09	9.58	13.81	16.91	19.98	26.90	31.28	1.72	3.34	4.90	6.05	7.21	9.85	11.54		<b>SGR2S 30B – 2018</b>
5.52	10.36	14.97	18.30	21.65	29.02	33.66	1.96	3.79	5.57	6.88	8.21	11.16	13.05		<b>SGR2S 32B – 2018</b>
5.95	11.13	16.12	19.73	23.32	31.09	35.99	2.22	4.27	6.29	7.78	9.27	12.54	14.63		<b>SGR2S 34B – 2018</b>
6.17	11.52	16.69	20.44	24.15	32.11	37.15	2.35	4.52	6.67	8.25	9.82	13.25	15.45		<b>SGR2S 35B – 2018</b>
6.39	11.90	17.26	21.16	24.98	33.13	38.29	2.49	4.78	7.06	8.73	10.39	13.98	16.29		<b>SGR2S 36B – 2018</b>
6.82	12.71	18.41	22.58	26.64	35.14	40.55	2.77	5.33	7.86	9.74	11.58	15.50	18.03		<b>SGR2S 38B – 2018</b>
7.25	13.52	19.55	23.99	28.29	37.13	42.62	3.08	5.92	8.70	10.79	12.82	17.08	19.76	<b>SGR2S 40B – 2020</b>	
7.68	14.32	20.70	25.39	29.91	39.06	44.59	3.39	6.53	9.61	11.90	14.13	18.72	21.54	<b>SGR2S 42B – 2020</b>	
8.10	15.12	21.86	26.79	31.47	40.98	46.54	3.73	7.17	10.55	13.06	15.46	20.43	23.38	<b>SGR2S 44B – 2020</b>	
8.32	15.52	22.44	27.49	32.24	41.93	47.49	3.90	7.50	11.04	13.66	16.15	21.30	24.32	<b>SGR2S 45B – 2020</b>	
8.95	16.71	24.17	29.58	34.52	44.57	50.29	4.44	8.54	12.57	15.53	18.27	23.93	27.22	<b>SGR2S 48B – 2020</b>	
9.37	17.51	25.32	30.96	36.01	46.24	52.09	4.81	9.27	13.64	16.85	19.75	25.73	29.22	<b>SGR2S 50B – 2025</b>	
10.42	19.47	28.18	34.23	39.67	50.27	56.40	5.82	11.21	16.51	20.26	23.67	30.42	34.41	0.14 to 0.24	<b>SGR2S 55B – 2025</b>
10.63	19.86	28.74	34.87	40.39	51.05	57.23	6.03	11.62	17.12	20.97	24.48	31.40	35.48		<b>SGR2S 56B – 2025</b>
11.45	21.42	31.00	37.39	43.22	54.09	61.60	6.92	13.33	19.64	23.92	27.88	35.39	40.63		<b>SGR2S 60B – 2025</b>
12.27	23.01	33.22	39.86	45.97	56.99	66.51	7.86	15.19	22.32	27.04	31.43	39.54	46.51		<b>SGR2S 64B – 2025</b>
13.48	25.38	36.34	43.47	49.63	61.58	73.89	9.37	18.19	26.51	32.03	36.86	46.39	56.12		<b>SGR2S 70B – 2025</b>
13.88	26.17	37.36	44.65	50.81	63.63	76.36	9.91	19.25	27.98	33.77	38.74	49.21	59.53		<b>SGR2S 72B – 2025</b>
14.51	27.34	38.88	46.39	52.55	66.73	80.07	10.76	20.90	30.25	36.45	41.62	53.61	64.85		<b>SGR2S 75B – 2025</b>
15.56	29.28	41.36	49.05	55.35	71.89	-	12.26	23.78	34.19	40.95	46.57	61.37	-		<b>SGR2S 80B – 2025</b>
17.62	33.07	46.11	53.92	60.54	82.16	-	15.54	30.08	42.69	50.41	57.05	78.55	-		<b>SGR2S 90B – 2025</b>
19.66	36.73	50.51	58.50	66.63	-	-	19.20	36.98	51.77	60.55	69.51	-	-	<b>SGR2S 100B – 2025</b>	



Unit: mm

Accuracy Class	Material	Pressure angle	Heat treatment	Tooth surface hardness	Surface treatment ①	Backlash ②
[JIS B 1702-1] N6	S45C	20°	Induction hardening of teeth	HRC50 to 56	Black oxide finish	See the table below

① A black oxide finish is applied to the gear surface, but not the tooth surfaces.

② This is a theoretical value obtained when a pair of gears of the same type and material are meshed with each other.

★ The allowable transfer capability table was prepared by using the formulas presented by the JGMA (Japan Gear Manufacturers Association). For the unit conversion method, refer to P. 20 in "References."

Catalogue number	Number of teeth	Reference diameter	Tip diameter	Type	Face width	Hole diameter	Hub diameter	Hub length	Overall length	Weight
	$z$	$d$	$d_a$		$b$	$d_a(H7)$	$d_h$	$l_h$	$l$	$W(kg)$
<b>SGR2.5S 14B – 2515</b>	14	φ 35	φ 40	B1	25	φ15	φ28	18	43	0.22
<b>SGR2.5S 15B – 2515</b>	15	φ 37.5	φ 42.5			φ15	φ30			0.26
<b>SGR2.5S 16B – 2515</b>	16	φ 40	φ 45			φ15	φ32			0.30
<b>SGR2.5S 18B – 2515</b>	18	φ 45	φ 50			φ15	φ38			0.41
<b>SGR2.5S 20B – 2518</b>	20	φ 50	φ 55			φ18	φ40			0.48
<b>SGR2.5S 24B – 2518</b>	24	φ 60	φ 65			φ18	φ48			0.72
<b>SGR2.5S 25B – 2520</b>	25	φ 62.5	φ 67.5			φ20	φ50			0.77
<b>SGR2.5S 28B – 2520</b>	28	φ 70	φ 75			φ20	φ60			1.05
<b>SGR2.5S 30B – 2520</b>	30	φ 75	φ 80			φ20	φ65			1.23
<b>SGR2.5S 32B – 2520</b>	32	φ 80	φ 85			φ20	φ70			1.42
<b>SGR2.5S 35B – 2520</b>	35	φ 87.5	φ 92.5			φ20	φ70			1.62
<b>SGR2.5S 36B – 2520</b>	36	φ 90	φ 95			φ20	φ70			1.69
<b>SGR2.5S 40B – 2525</b>	40	φ100	φ105			φ25	φ70			1.92
<b>SGR2.5S 45B – 2525</b>	45	φ112.5	φ117.5			φ25	φ75			2.41
<b>SGR2.5S 48B – 2525</b>	48	φ120	φ125			φ25	φ75			2.68
<b>SGR2.5S 50B – 2525</b>	50	φ125	φ130			φ25	φ80			2.95
<b>SGR2.5S 55B – 2525</b>	55	φ137.5	φ142.5			φ25	φ80			3.46
<b>SGR2.5S 56B – 2525</b>	56	φ140	φ145			φ25	φ80			3.57
<b>SGR2.5S 60B – 2525</b>	60	φ150	φ155			φ25	φ80			4.01
<b>SGR2.5S 64B – 2525</b>	64	φ160	φ165			φ25	φ80			4.49
<b>SGR2.5S 70B – 2525</b>	70	φ175	φ180	φ25	φ80	5.26				
<b>SGR2.5S 72B – 2525</b>	72	φ180	φ185	φ25	φ85	5.63				
<b>SGR2.5S 75B – 2525</b>	75	φ187.5	φ192.5	φ25	φ90	6.15				
<b>SGR2.5S 80B – 2525</b>	80	φ200	φ205	φ25	φ90	6.90				



2D • 3D CAD

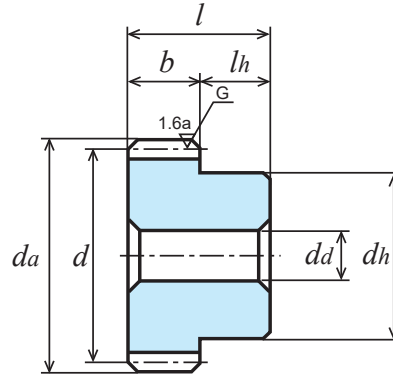

B1 type

Allowable transfer capability table for different revolutions per minute, Bending strength, (Unit: kW)							Allowable transfer capability table for different revolutions per minute, Surface durability, (Unit: kW)							Backlash (Unit: mm)	Catalogue number
400 rpm	800 rpm	1,200 rpm	1,500 rpm	1,800 rpm	2,500 rpm	3,000 rpm	400 rpm	800 rpm	1,200 rpm	1,500 rpm	1,800 rpm	2,500 rpm	3,000 rpm		
3.21	6.28	9.09	11.07	13.05	17.61	20.79	0.70	1.42	2.09	2.57	3.05	4.18	4.98	0.10 to 0.20	<b>SGR2.5S 14B – 2515</b>
3.64	7.08	10.22	12.44	14.71	19.82	23.43	0.81	1.63	2.40	2.94	3.51	4.80	5.72		<b>SGR2.5S 15B – 2515</b>
4.06	7.86	11.55	13.80	16.32	21.99	26.00	0.93	1.86	2.76	3.35	4.00	5.46	6.51		<b>SGR2.5S 16B – 2515</b>
4.87	9.33	13.39	16.40	19.38	26.13	30.84	1.19	2.35	3.44	4.25	5.06	6.93	8.24		<b>SGR2.5S 18B – 2515</b>
5.69	10.82	15.51	19.05	22.46	30.32	35.73	1.48	2.90	4.24	5.26	6.25	8.56	10.16		<b>SGR2.5S 20B – 2518</b>
7.32	13.78	19.87	24.33	28.74	38.69	45.00	2.15	4.17	6.12	7.57	9.01	12.31	14.43	0.12 to 0.22	<b>SGR2.5S 24B – 2518</b>
7.73	14.52	20.97	25.65	30.33	40.73	47.27	2.33	4.52	6.64	8.21	9.78	13.33	15.60		<b>SGR2.5S 25B – 2520</b>
8.97	16.73	24.25	29.70	35.09	46.66	53.98	2.94	5.65	8.34	10.31	12.28	16.57	19.32		<b>SGR2.5S 28B – 2520</b>
9.79	18.24	26.42	32.40	38.24	50.51	58.31	3.38	6.49	9.57	11.85	14.10	18.89	21.98		<b>SGR2.5S 30B – 2520</b>
10.61	19.78	28.60	35.11	41.39	54.32	62.36	3.85	7.39	10.88	13.49	16.03	21.34	24.70		<b>SGR2.5S 32B – 2520</b>
11.84	22.09	31.94	39.16	46.01	59.93	68.10	4.61	8.86	13.04	16.14	19.12	25.26	28.94		<b>SGR2.5S 35B – 2520</b>
12.67	23.64	34.19	41.89	49.12	63.87	72.36	4.87	9.37	13.79	17.06	20.17	26.61	30.38		<b>SGR2.5S 36B – 2520</b>
13.88	25.92	37.49	45.84	53.31	68.46	77.12	6.02	11.58	17.06	21.06	24.69	32.16	36.52	<b>SGR2.5S 40B – 2525</b>	
15.88	29.68	42.96	52.10	60.33	76.21	85.42	7.61	14.65	21.59	26.44	30.86	39.55	44.69	0.14 to 0.24	<b>SGR2.5S 45B – 2525</b>
17.08	31.93	46.22	55.75	64.44	80.64	91.85	8.64	16.66	24.55	29.90	34.84	44.24	50.79		<b>SGR2.5S 48B – 2525</b>
17.87	33.47	48.38	58.15	67.13	83.50	96.56	9.37	18.10	26.63	32.32	37.61	47.46	55.32		<b>SGR2.5S 50B – 2525</b>
19.82	37.30	53.49	64.02	73.24	90.33	108.41	11.31	21.93	32.02	38.70	44.63	55.84	67.55		<b>SGR2.5S 55B – 2525</b>
20.20	38.06	54.49	65.17	74.41	92.32	110.78	11.71	22.74	33.14	40.03	46.07	57.99	70.15		<b>SGR2.5S 56B – 2525</b>
21.81	41.09	58.43	69.71	78.97	100.27	120.32	13.45	26.12	37.81	45.56	52.02	67.01	81.06		<b>SGR2.5S 60B – 2525</b>
23.43	44.09	62.28	73.86	83.34	108.25	-	15.32	29.73	42.74	51.19	58.22	76.71	-		<b>SGR2.5S 64B – 2525</b>
25.85	48.56	67.92	79.69	89.58	120.27	-	18.36	35.55	50.62	59.97	67.96	92.56	-		<b>SGR2.5S 70B – 2525</b>
26.65	50.03	69.76	81.57	91.59	124.29	-	19.43	37.60	53.36	63.01	71.32	98.18	-		<b>SGR2.5S 72B – 2525</b>
27.85	52.23	72.48	84.32	94.51	130.32	-	21.09	40.78	57.60	67.67	76.45	106.95	-		<b>SGR2.5S 75B – 2525</b>
29.83	55.73	76.65	88.76	101.10	-	-	24.00	46.22	64.72	75.68	86.89	-	-	<b>SGR2.5S 80B – 2525</b>	



Unit: mm

Accuracy Class	Material	Pressure angle	Heat treatment	Tooth surface hardness	Surface treatment ①	Backlash ②
[JIS B 1702-1] N6	S45C	20°	Induction hardening of teeth	HRC50 to 56	Black oxide finish	See the table below

① A black oxide finish is applied to the gear surface, but not the tooth surfaces.

② This is a theoretical value obtained when a pair of gears of the same type and material are meshed with each other.

★ The allowable transfer capability table was prepared by using the formulas presented by the JGMA (Japan Gear Manufacturers Association). For the unit conversion method, refer to P. 20 in "References."

Catalogue number	Number of teeth	Reference diameter	Tip diameter	Type	Face width	Hole diameter	Hub diameter	Hub length	Overall length	Weight
	$z$	$d$	$d_a$		$b$	$d_a(H7)$	$d_h$	$l_h$	$l$	$W(kg)$
SGR3S 14B – 3016	14	φ 42	φ 48	B1	30	φ 16	φ 34	20	50	0.39
SGR3S 15B – 3016	15	φ 45	φ 51			φ 16	φ 36			0.46
SGR3S 16B – 3016	16	φ 48	φ 54			φ 16	φ 38			0.53
SGR3S 18B – 3016	18	φ 54	φ 60			φ 16	φ 40			0.66
SGR3S 20B – 3020	20	φ 60	φ 66			φ 20	φ 50			0.85
SGR3S 24B – 3020	24	φ 72	φ 78			φ 20	φ 58			1.25
SGR3S 25B – 3020	25	φ 75	φ 81			φ 20	φ 60			1.36
SGR3S 28B – 3020	28	φ 84	φ 90			φ 20	φ 70			1.79
SGR3S 30B – 3025	30	φ 90	φ 96			φ 25	φ 75			2.00
SGR3S 32B – 3025	32	φ 96	φ 102			φ 25	φ 75			2.21
SGR3S 35B – 3025	35	φ 105	φ 111			φ 25	φ 80			2.64
SGR3S 36B – 3025	36	φ 108	φ 114			φ 25	φ 80			2.75
SGR3S 40B – 3025	40	φ 120	φ 126			φ 25	φ 80			3.26
SGR3S 45B – 3025	45	φ 135	φ 141			φ 25	φ 80			3.97
SGR3S 48B – 3025	48	φ 144	φ 150			φ 25	φ 85			4.53
SGR3S 50B – 3030	50	φ 150	φ 156			φ 30	φ 85			4.78
SGR3S 55B – 3030	55	φ 165	φ 171			φ 30	φ 90			5.76
SGR3S 56B – 3030	56	φ 168	φ 174			φ 30	φ 90			5.94
SGR3S 60B – 3030	60	φ 180	φ 186			φ 30	φ 100			6.95
SGR3S 64B – 3030	64	φ 192	φ 198			φ 30	φ 100			7.77
SGR3S 70B – 3030	70	φ 210	φ 216	φ 30	φ 100	9.11				
SGR3S 72B – 3030	72	φ 216	φ 222	φ 30	φ 100	9.59				
SGR3S 75B – 3030	75	φ 225	φ 231	φ 30	φ 100	10.32				
SGR3S 80B – 3030	80	φ 240	φ 246	φ 30	φ 100	11.61				



2D • 3D CAD

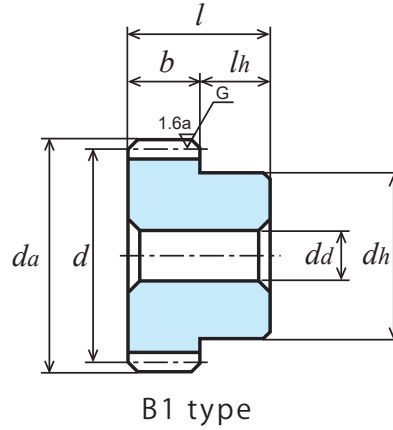

Allowable transfer capability table for different revolutions per minute, Bending strength, (Unit: kW)							Allowable transfer capability table for different revolutions per minute, Surface durability, (Unit: kW)							Backlash (Unit: mm)	Catalogue number
400 rpm	800 rpm	1,200 rpm	1,500 rpm	1,800 rpm	2,500 rpm	3,000 rpm	400 rpm	800 rpm	1,200 rpm	1,500 rpm	1,800 rpm	2,500 rpm	3,000 rpm		
5.55	10.69	15.39	18.79	22.22	29.94	35.37	1.24	2.46	3.60	4.44	5.29	7.23	8.61	0.10 to 0.20	<b>SGR3S 14B – 3016</b>
6.29	12.04	17.29	21.18	25.02	33.74	39.82	1.43	2.82	4.12	5.10	6.07	8.31	9.89		<b>SGR3S 15B – 3016</b>
7.01	13.36	19.13	23.51	27.74	37.44	44.13	1.64	3.21	4.68	5.81	6.91	9.46	11.24		<b>SGR3S 16B – 3016</b>
8.36	15.83	22.75	27.90	32.89	44.40	52.07	2.08	4.06	5.94	7.36	8.74	11.98	14.16	0.12 to 0.22	<b>SGR3S 18B – 3016</b>
9.73	18.33	26.42	32.35	38.21	51.45	59.84	2.58	5.01	7.35	9.08	10.81	14.77	17.32		<b>SGR3S 20B – 3020</b>
12.49	23.28	33.77	41.38	48.86	64.80	74.98	3.73	7.17	10.58	13.55	15.59	20.97	24.44		<b>SGR3S 24B – 3020</b>
13.19	24.58	35.61	43.67	51.53	68.07	78.59	4.05	7.79	11.48	14.22	16.92	22.67	26.38		<b>SGR3S 25B – 3020</b>
15.27	28.49	41.19	50.53	59.52	77.73	88.75	5.09	9.79	14.41	17.85	21.20	28.08	32.32		<b>SGR3S 28B – 3020</b>
16.66	31.08	44.95	55.07	64.57	83.97	95.12	5.85	11.25	16.56	20.49	24.22	31.95	36.49		<b>SGR3S 30B – 3025</b>
18.04	33.68	48.71	59.61	69.55	89.80	101.33	6.66	12.81	18.86	23.30	27.41	35.90	40.83	<b>SGR3S 32B – 3025</b>	
20.11	37.56	54.34	66.26	76.88	98.07	110.25	7.96	15.32	22.57	27.79	32.51	42.06	47.67	0.14 to 0.24	<b>SGR3S 35B – 3025</b>
20.79	38.84	56.21	68.39	79.29	100.74	113.12	8.42	16.21	23.88	29.34	34.29	44.19	50.02		<b>SGR3S 36B – 3025</b>
23.52	43.98	63.65	76.77	88.74	111.05	126.48	10.37	20.00	29.46	35.89	41.81	53.08	60.95		<b>SGR3S 40B – 3025</b>
26.85	50.49	72.54	86.88	99.60	123.01	146.54	13.09	25.36	37.09	44.86	51.84	64.95	78.00		<b>SGR3S 45B – 3025</b>
28.85	54.39	77.66	92.80	105.61	132.26	158.71	14.86	28.88	41.97	50.65	58.11	73.82	89.30		<b>SGR3S 48B – 3025</b>
30.24	56.98	81.02	96.67	109.51	139.05	166.86	16.14	31.35	45.37	54.67	62.42	80.41	97.27		<b>SGR3S 50B – 3030</b>
33.71	63.40	89.26	105.47	118.86	156.10	-	19.57	37.93	54.36	64.87	73.69	98.18	-		<b>SGR3S 55B – 3030</b>
34.40	64.68	90.88	107.15	120.66	159.52	-	20.29	39.32	56.25	66.97	76.02	101.96	-		<b>SGR3S 56B – 3030</b>
37.15	69.75	97.25	113.71	127.68	173.26	-	23.31	45.12	64.04	75.61	85.58	117.82	-		<b>SGR3S 60B – 3030</b>
39.89	74.75	103.42	120.01	134.68	-	-	26.54	51.28	72.21	84.62	95.72	-	-		<b>SGR3S 64B – 3030</b>
43.95	81.77	111.67	129.00	149.63	-	-	31.76	60.91	84.68	98.78	115.49	-	-		<b>SGR3S 70B – 3030</b>
45.29	84.07	114.33	131.88	154.63	-	-	33.59	64.28	88.99	103.66	122.51	-	-		<b>SGR3S 72B – 3030</b>
47.29	87.48	118.24	136.10	162.14	-	-	36.44	69.49	95.60	111.13	133.45	-	-		<b>SGR3S 75B – 3030</b>
50.62	93.07	124.54	145.58	174.69	-	-	41.44	78.55	106.99	126.30	152.77	-	-		<b>SGR3S 80B – 3030</b>

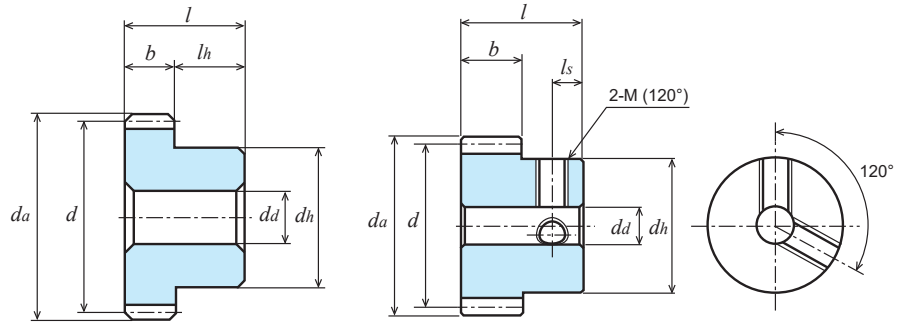

Unit: mm

B1 type [-]

B1 type [\*]

Accuracy Class	Material	Pressure angle	Heat treatment	Tooth surface hardness	Backlash ①
[JIS B 1702-1] N8	S45C	20°	—	—	0.02 to 0.06

★ No surface treatment is applied. [\*] Two screw holes and set screws are provided.

★ This allowable transfer capability table was prepared by using the formulas presented by the JGMA (Japan Gear Manufacturers Association). For the unit conversion method, refer to P. 20 in "References."

① This is a theoretical value obtained when a pair of gears of the same type and material are meshed with each other.

Catalogue number	Number of teeth <i>z</i>	Reference diameter <i>d</i>	Tip diameter <i>da</i>	Type	Face width <i>b</i>	Hole diameter <i>da</i> (H7)	Hub diameter <i>dh</i>	Hub length <i>lh</i>	Overall length <i>l</i>	Screw		Weight <i>W</i> (g)
										2-M(120°)	<i>ls</i>	
S50S 10K — 1006	10	φ 5	φ 6	K1	10	-	φ 6	45	55	-	-	11.5
S50S 12K — 1007	12	φ 6	φ 7	K1	10	-	φ 7	45	55	-	-	15.8
S50S 15K * 0803	15	φ 7.5	φ 8.5	K2	8	φ3(H8)	φ 8.5	10	18	2-M3	3	6.0
S50S 16K * 0803	16	φ 8	φ 9	K2	8	φ3(H8)	φ 9	10	18	2-M3	3	6.9
S50S 18K * 0804	18	φ 9	φ 10	K2	8	φ4(H8)	φ 10	10	18	2-M3	3	8.1
S50S 20K * 0804	20	φ 10	φ 11	K2	8	φ4(H8)	φ 11	10	18	2-M3	3	10.3
S50S 22K * 0804	22	φ 11	φ 12	K2	8	φ4(H8)	φ 12	10	18	2-M3	3	12.7
S50S 24K * 0804	24	φ 12	φ 13	K2	8	φ4(H8)	φ 13	10	18	2-M3	3	15.4
S50S 25B * 0804	25	φ 12.5	φ 13.5	B1	8	φ4(H8)	φ 10	8	16	2-M3	4	10.8
S50S 26B * 0804	26	φ 13	φ 14	B1	8	φ4(H8)	φ 10	8	16	2-M3	4	11.4
S50S 28B * 0804	28	φ 14	φ 15	B1	8	φ4(H8)	φ 10	8	16	2-M3	4	12.8
S50S 30B * 0805	30	φ 15	φ 16	B1	8	φ5(H8)	φ 12	8	16	2-M3	4	15.4
S50S 32B * 0505	32	φ 16	φ 17	B1	5	φ 5	φ 12	8	13	2-M3	4	12.7
S50S 35B * 0505	35	φ 17.5	φ 18.5	B1	5	φ 5	φ 12	8	13	2-M3	4	14.2
S50S 36B * 0505	36	φ 18	φ 19	B1	5	φ 5	φ 12	8	13	2-M3	4	14.8
S50S 40BF — 0504	40	φ 20	φ 21	B1	5	φ4(H8)	φ 15	8	13	-	-	22.1
S50S 40B * 0505	40	φ 20	φ 21	B1	5	φ 5	φ 15	8	13	2-M3	4	21.0
S50S 42B * 0505	42	φ 21	φ 22	B1	5	φ 5	φ 15	8	13	2-M3	4	22.3
S50S 44B * 0505	44	φ 22	φ 23	B1	5	φ 5	φ 15	8	13	2-M3	4	23.6
S50S 45B * 0505	45	φ 22.5	φ 23.5	B1	5	φ 5	φ 15	8	13	2-M3	4	24.3
S50S 48B * 0505	48	φ 24	φ 25	B1	5	φ 5	φ 15	8	13	2-M3	4	26.4
S50S 50B * 0505	50	φ 25	φ 26	B1	5	φ 5	φ 15	8	13	2-M3	4	27.9
S50S 52B * 0505	52	φ 26	φ 27	B1	5	φ 5	φ 15	8	13	2-M3	4	29.5
S50S 54B * 0505	54	φ 27	φ 28	B1	5	φ 5	φ 15	8	13	2-M3	4	31.1
S50S 55B * 0505	55	φ 27.5	φ 28.5	B1	5	φ 5	φ 15	8	13	2-M3	4	32.0
S50S 56B * 0505	56	φ 28	φ 29	B1	5	φ 5	φ 15	8	13	2-M3	4	32.8
S50S 60B * 0506	60	φ 30	φ 31	B1	5	φ 6	φ 18	8	13	2-M4	4	39.9
S50S 64B * 0506	64	φ 32	φ 33	B1	5	φ 6	φ 18	8	13	2-M4	4	43.7
S50S 70B * 0506	70	φ 35	φ 36	B1	5	φ 6	φ 18	8	13	2-M4	4	49.9
S50S 72B * 0506	72	φ 36	φ 37	B1	5	φ 6	φ 18	8	13	2-M4	4	52.1
S50S 75B * 0506	75	φ 37.5	φ 38.5	B1	5	φ 6	φ 18	8	13	2-M4	4	55.5
S50S 80BF — 0506	80	φ 40	φ 41	B1	5	φ 6	φ 28	8	13	-	-	85.0
S50S 80B * 0508	80	φ 40	φ 41	B1	5	φ 8	φ 22	8	13	2-M4	4	67.0
S50S 90B * 0508	90	φ 45	φ 46	B1	5	φ 8	φ 22	8	13	2-M4	4	80.1
S50S 96B * 0508	96	φ 48	φ 49	B1	5	φ 8	φ 22	8	13	2-M4	4	88.7

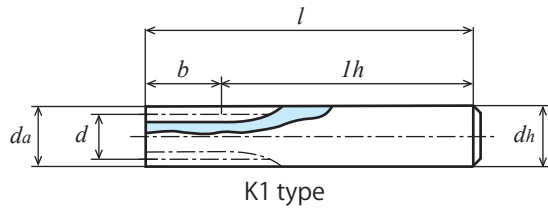

K1 type

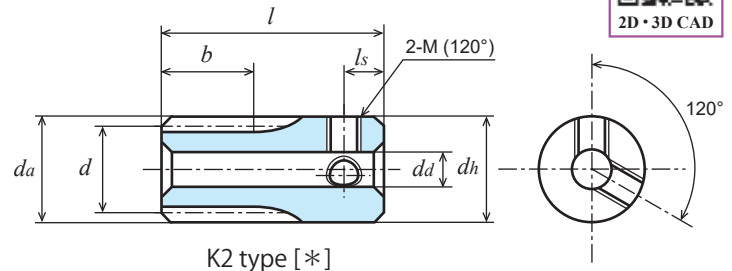

K2 type [\*]

Catalogue number	Number of teeth <i>z</i>	Reference diameter <i>d</i>	Tip diameter <i>da</i>	Type	Face width <i>b</i>	Hole diameter <i>da(H7)</i>	Hub diameter <i>dh</i>	Hub length <i>lh</i>	Overall length <i>l</i>	Screw		Weight <i>W(g)</i>
										2-M(120°)	<i>ls</i>	
S50S 100B * 0508	100	φ50	φ51	B1	5	φ8	φ25	8	13	2-M4	4	101.4
S50S 110B * 0508	110	φ55	φ56	B1	5	φ8	φ25	8	13	2-M4	4	117.6
S50S 120B * 0508	120	φ60	φ61	B1	5	φ8	φ25	8	13	2-M4	4	135.4

Catalogue number	Allowable transfer capability table for different revolutions per minute, Bending strength, (Unit: W)						
	10rpm	100rpm	200rpm	400rpm	800rpm	1,200rpm	1,500rpm
S50S 10K — 1006	0.62	6.19	12.38	24.77	49.53	74.30	92.87
S50S 12K — 1007	0.85	8.49	16.98	33.96	67.91	101.87	127.33
S50S 15K * 0803	0.99	9.92	19.84	39.68	79.37	119.05	148.81
S50S 16K * 0803	1.10	11.01	22.02	44.04	88.08	132.12	165.15
S50S 18K * 0804	1.32	13.24	26.47	52.94	105.88	158.82	198.53
S50S 20K * 0804	1.55	15.54	31.08	62.16	124.32	186.48	233.10
S50S 22K * 0804	1.79	17.88	35.76	71.52	143.04	214.57	268.21
S50S 24K * 0804	2.03	20.26	40.52	81.04	162.07	243.11	303.88
S50S 25B * 0804	2.15	21.46	42.93	85.86	172.72	257.57	321.97
S50S 26B * 0804	2.27	22.68	45.36	90.71	181.43	272.14	339.11
S50S 28B * 0804	2.51	25.13	50.26	100.52	201.03	301.55	371.39
S50S 30B * 0805	2.76	27.59	55.18	110.37	220.74	331.11	403.12
S50S 32B * 0505	1.88	18.81	37.61	75.22	150.44	225.49	271.63
S50S 35B * 0505	2.12	21.17	42.34	84.68	169.36	250.30	300.66
S50S 36B * 0505	2.20	21.96	43.93	87.85	175.71	258.48	310.20
S50S40BF — 0504	2.51	25.13	50.26	100.53	201.05	290.27	347.13
S50S 40B * 0505	2.52	25.16	50.32	100.65	201.29	290.74	347.65
S50S 42B * 0505	2.68	26.77	53.55	107.09	214.19	306.59	365.96
S50S 44B * 0505	2.84	28.37	56.75	113.49	226.99	322.02	383.71
S50S 45B * 0505	2.92	29.18	58.37	116.74	233.47	329.75	392.59
S50S 48B * 0505	3.16	31.63	63.25	126.50	252.80	352.63	418.79
S50S 50B * 0505	3.33	33.26	66.52	133.04	264.20	367.63	435.89
S50S 52B * 0505	3.49	34.90	69.80	139.60	275.51	382.44	452.72
S50S 54B * 0505	3.65	36.54	73.08	146.17	286.71	397.03	469.26
S50S 55B * 0505	3.74	37.37	74.73	149.46	292.27	404.26	477.43
S50S 56B * 0505	3.82	38.19	76.38	152.76	297.80	411.43	485.53
S50S 60B * 0506	4.15	41.50	83.00	165.99	319.68	439.63	517.25
S50S 64B * 0506	4.48	44.82	89.64	179.28	341.14	467.04	547.92
S50S 70B * 0506	4.98	49.82	99.65	199.30	372.55	506.74	592.05
S50S 72B * 0506	5.15	51.50	102.99	205.99	382.81	519.61	606.27
S50S 75B * 0506	5.40	54.01	108.02	216.04	398.01	538.57	627.16
S50S80BF — 0506	5.78	57.80	115.61	231.21	419.70	565.46	662.85
S50S 80B * 0508	5.82	58.21	116.42	232.85	422.85	569.31	668.04
S50S 90B * 0508	6.66	66.56	133.13	266.25	470.10	626.91	752.57
S50S 96B * 0508	7.16	71.63	143.26	286.28	497.59	660.77	802.70
S50S 100B * 0508	7.50	75.01	150.02	297.93	515.45	688.64	835.69
S50S 110B * 0508	8.35	83.48	166.96	326.48	558.60	757.32	916.71
S50S 120B * 0508	9.20	91.98	183.95	354.27	599.68	824.59	995.68



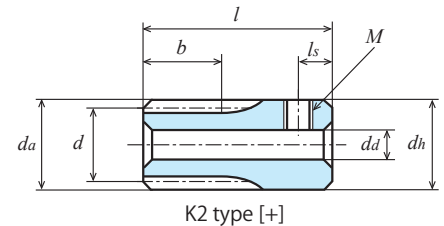
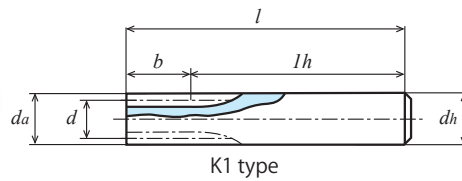

Unit: mm

Accuracy Class	Material	Pressure angle	Heat treatment	Tooth surface hardness	Backlash ①
[JIS B 1702-1] N8	S45C	20°	—	—	0.02 to 0.06

★ No surface treatment is applied. Gears with a [+] are provided with one screw hole and set screw.

★ This allowable transfer capability table was prepared by using the formulas presented by the JGMA (Japan Gear Manufacturers Association). For the unit conversion method, refer to P. 20 in "References."

① This is a theoretical value obtained when a pair of gears of the same type and material are meshed with each other.

Catalogue number	Module <i>m</i>	Number of teeth <i>z</i>	Reference diameter <i>d</i>	Tip diameter <i>da</i>	Type	Face width <i>b</i>	Hole diameter <i>da(H7)</i>	Hub diameter <i>dh</i>	Hub length <i>lh</i>	Overall length <i>l</i>	Screw		Weight <i>W(g)</i>
											<i>M</i>	<i>ls</i>	
<b>S75S 10K – 0809</b>	0.75	10	φ 7.5	φ 9	K1	8	-	φ 9	47	55	-	-	26.3
<b>S75S 12K – 0811</b>		12	φ 9	φ10.5	K1	8	-	φ11	47	55	-	-	39.1
<b>S75S 14K + 0805</b>		14	φ10.5	φ12	K2	8	φ5(H8)	φ12	12	20	M3	3	12.9
<b>S75S 15K + 0805</b>		15	φ11.25	φ12.75	K2	8	φ5(H8)	φ12.75	12	20	M3	3	15.0
<b>S75S 16B + 0805</b>		16	φ12	φ13.5	B1	8	φ5(H8)	φ10	7	15	M4	3.5	8.9
<b>S75S 18B + 0805</b>		18	φ13.5	φ15	B1	8	φ5(H8)	φ11	7	15	M4	3.5	11.7
<b>S75S 20B + 0806</b>		20	φ15	φ16.5	B1	8	φ6	φ12	7	15	M4	3.5	13.8
<b>S75S 24B + 0806</b>		24	φ18	φ19.5	B1	8	φ6	φ14	7	15	M4	3.5	20.8
<b>S75S 28B + 0806</b>		28	φ21	φ22.5	B1	8	φ6	φ14	7	15	M4	3.5	26.6
<b>S75S 30B + 0806</b>		30	φ22.5	φ24	B1	8	φ6	φ15	7	15	M4	3.5	31.0
<b>S75S 32B + 0606</b>		32	φ24	φ25.5	B1	6	φ6	φ15	9	15	M4	4	30.1
<b>S75S 35B + 0606</b>		35	φ26.25	φ27.75	B1	6	φ6	φ18	9	15	M4	4	39.7
<b>S75S 36B + 0606</b>		36	φ27	φ28.5	B1	6	φ6	φ18	9	15	M4	4	41.2
<b>S75S 40B + 0606</b>		40	φ30	φ31.5	B1	6	φ6	φ20	9	15	M4	4	51.7
<b>S75S 45B + 0606</b>		45	φ33.75	φ35.25	B1	6	φ6	φ20	9	15	M4	4	60.5
<b>S75S 48B + 0606</b>		48	φ36	φ37.5	B1	6	φ6	φ20	9	15	M4	4	66.3
<b>S75S 50B + 0606</b>		50	φ37.5	φ39	B1	6	φ6	φ20	9	15	M4	4	70.4
<b>S75S 56B + 0606</b>		56	φ42	φ43.5	B1	6	φ6	φ20	9	15	M4	4	83.6
<b>S75S 60B + 0606</b>		60	φ45	φ46.5	B1	6	φ6	φ22	9	15	M4	4	97.9
<b>S75S 64B + 0606</b>		64	φ48	φ49.5	B1	6	φ6	φ22	9	15	M4	4	108.2
<b>S75S 70B + 0606</b>		70	φ52.5	φ54	B1	6	φ6	φ22	9	15	M4	4	124.9
<b>S75S 72B + 0606</b>		72	φ54	φ55.5	B1	6	φ6	φ25	9	15	M4	4	138.5
<b>S75S 80B + 0608</b>		80	φ60	φ61.5	B1	6	φ8	φ25	9	15	M4	4	161.3
<b>S75S 90B + 0608</b>		90	φ67.5	φ69	B1	6	φ8	φ30	9	15	M4	4	211.8
<b>S75S 100B + 0608</b>	100	φ75	φ76.5	B1	6	φ8	φ30	9	15	M4	4	251.3	
<b>S75S 120B + 0608</b>	120	φ90	φ91.5	B1	6	φ8	φ30	9	15	M4	4	342.9	
<b>S80S 25BF – 0805</b>	0.8	25	φ20	φ21.6	B1	8	φ5(H8)	φ16	10	18	-	-	32.5
<b>S80S 30BF – 0805</b>		30	φ24	φ25.6	B1	8	φ5(H8)	φ20	10	18	-	-	50.1
<b>S80S 40BF – 0806</b>		40	φ32	φ33.6	B1	8	φ6(H8)	φ25	10	18	-	-	84.7
<b>S80S 50BF – 0806</b>		50	φ40	φ41.6	B1	8	φ6(H8)	φ28	10	18	-	-	122.9
<b>S80S 60BF – 0806</b>		60	φ48	φ49.6	B1	8	φ6(H8)	φ34	10	18	-	-	180.5
<b>S80S 70BF – 0808</b>		70	φ56	φ57.6	B1	8	φ8	φ40	10	18	-	-	245.7



2D • 3D CAD

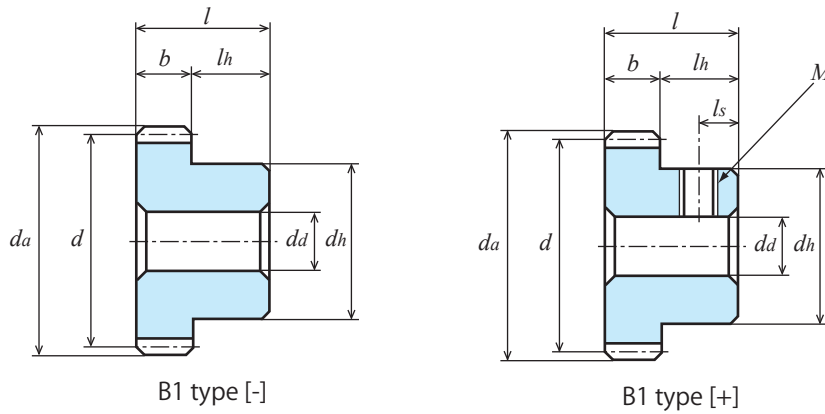

B1 type [-]

B1 type [+]

Catalogue number	Module <i>m</i>	Number of teeth <i>z</i>	Reference diameter <i>d</i>	Tip diameter <i>da</i>	Type	Face width <i>b</i>	Hole diameter <i>da</i> (H7)	Hub diameter <i>dh</i>	Hub length <i>lh</i>	Overall length <i>l</i>	Screw		Weight <i>W</i> (g)
											<i>M</i>	<i>ls</i>	
<b>S80S 80BF – 0808</b>	0.8	80	φ64	φ65.6	B1	8	φ 8	φ45	10	18	-	-	319.2
<b>S80S 90BF – 0808</b>		90	φ72	φ73.6	B1	8	φ 8	φ50	10	18	-	-	402.1
<b>S80S 100BF – 0810</b>		100	φ80	φ81.6	B1	8	φ10	φ60	10	18	-	-	525.8
<b>S80S 120BF – 0810</b>		120	φ96	φ97.6	B1	8	φ10	φ70	10	18	-	-	744.7

Catalogue number	Allowable transfer capability table for different revolutions per minute, Bending strength, (Unit: W)						
	10rpm	100rpm	200rpm	400rpm	800rpm	1,200rpm	1,500rpm
<b>S75S 10K – 0809</b>	1.10	11.07	22.14	44.29	88.59	132.88	166.10
<b>S75S 12K – 0811</b>	1.53	15.28	30.56	61.12	122.24	183.36	229.20
<b>S75S 14K + 0805</b>	1.99	19.92	39.84	79.67	159.35	239.02	298.77
<b>S75S 15K + 0805</b>	2.23	22.32	44.64	89.29	178.58	267.86	334.83
<b>S75S 16B + 0805</b>	2.48	24.77	49.54	99.09	198.18	297.27	371.59
<b>S75S 18B + 0805</b>	2.98	29.78	59.56	119.12	238.23	357.35	442.68
<b>S75S 20B + 0806</b>	3.50	34.97	69.93	139.86	279.72	419.58	510.83
<b>S75S 24B + 0806</b>	4.56	45.58	91.17	182.33	364.66	536.45	643.79
<b>S75S 28B + 0806</b>	5.65	56.54	113.08	226.16	452.32	647.45	772.83
<b>S75S 30B + 0806</b>	6.21	62.08	124.17	248.66	496.66	701.46	835.14
<b>S75S 32B + 0606</b>	5.08	50.78	101.55	203.10	405.88	566.16	672.37
<b>S75S 35B + 0606</b>	5.72	57.16	114.32	228.63	450.54	625.02	739.59
<b>S75S 36B + 0606</b>	5.93	59.30	118.60	237.20	465.26	644.30	761.51
<b>S75S 40B + 0606</b>	6.79	67.94	135.87	271.74	523.34	719.70	846.78
<b>S75S 45B + 0606</b>	7.88	78.80	157.59	315.19	593.54	809.50	947.38
<b>S75S 48B + 0606</b>	8.54	85.39	170.78	341.55	634.74	861.57	1,005.26
<b>S75S 50B + 0606</b>	8.98	89.80	179.60	359.20	661.75	895.45	1,042.75
<b>S75S 56B + 0606</b>	10.31	103.12	206.23	412.46	740.57	993.21	1,176.28
<b>S75S 60B + 0606</b>	11.20	112.05	224.09	448.18	791.32	1,055.28	1,266.80
<b>S75S 64B + 0606</b>	12.10	121.01	242.03	483.67	840.68	1,116.37	1,356.16
<b>S75S 70B + 0606</b>	13.45	134.52	269.05	530.18	912.13	1,227.65	1,487.91
<b>S75S 72B + 0606</b>	13.90	139.04	278.08	545.45	935.29	1,264.36	1,531.23
<b>S75S 80B + 0608</b>	15.72	157.17	314.34	605.38	1,024.75	1,409.08	1,701.45
<b>S75S 90B + 0608</b>	17.97	179.72	359.44	676.87	1,128.44	1,583.37	1,911.84
<b>S75S 100B + 0608</b>	20.25	202.52	405.04	746.20	1,239.53	1,753.91	2,124.81
<b>S75S 120B + 0608</b>	24.83	248.33	496.67	876.93	1,484.26	2,095.89	2,535.81
<b>S80S 25BF – 0805</b>	5.52	55.18	110.37	220.74	441.48	637.09	761.80
<b>S80S 30BF – 0805</b>	7.07	70.68	141.37	282.73	565.46	848.19	936.16
<b>S80S 40BF – 0806</b>	10.28	102.83	205.66	411.32	782.43	1,071.87	1,256.58
<b>S80S 50BF – 0806</b>	13.57	135.71	271.42	542.84	985.16	1,326.95	1,556.59
<b>S80S60BF – 0806</b>	16.90	169.01	338.02	675.62	1,174.49	1,559.42	1,894.30
<b>S80S70BF – 0808</b>	20.27	202.73	405.46	790.39	1,349.57	1,834.61	2,219.44
<b>S80S80BF – 0808</b>	23.68	236.76	473.52	900.97	1,512.09	2,102.26	2,535.16
<b>S80S90BF – 0808</b>	27.05	270.48	540.96	1,005.69	1,663.72	2,358.61	2,854.02
<b>S80S100BF – 0810</b>	30.47	304.72	609.44	1,106.63	1,850.53	2,609.92	3,168.16
<b>S80S120BF – 0810</b>	37.33	373.31	746.20	1,296.79	2,210.75	3,123.87	3,771.32

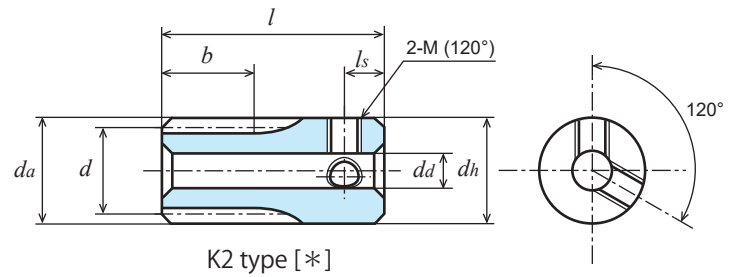

K2 type [\*]

Unit: mm

Accuracy Class	Material	Pressure angle	Heat treatment	Tooth surface hardness	Backlash ①
[JIS B 1702-1] N8	S45C	20°	—	—	0.04 to 0.10

★ No surface treatment is applied. [\*] Two screw holes and set screws are provided. Gears with a [=] are provided with key grooves and keys.

★ This allowable transfer capability table was prepared by using the formulas presented by the JGMA (Japan Gear Manufacturers Association). For the unit conversion method, refer to P. 20 in "References."

★ KG standard products have different transfer capabilities depending on whether the face width is "Standard" (for light loads) or "Wide" (for heavy loads).

★ [Profile-shifted] is a profile-shifted gear with a rack shift coefficient x of 0.5.

Catalogue number	Number of teeth <i>z</i>	Refer-ence diameter <i>d</i>	Tip diameter <i>da</i>	Type	Face width <i>b</i>	Hole diameter <i>da</i> (H7)	Hub diameter <i>dh</i>	Hub length <i>lh</i>	Overall length <i>l</i>	Key groove <i>b</i> <sub>2</sub> × <i>t</i> <sub>2</sub>	Screw		Weight <i>W</i> (g)
											2-M(120°)	<i>ls</i>	
S1S 8L — 1210F	8	[Profile-shifted]	φ10.64	L2	12	-	φ10.64	L16 R32	60	-	-	-	39.5
S1S 10L — 1208	10	[Profile-shifted]	φ12.66	L1	12	-	φ 8 (h9)	L16 R32	60	-	-	-	27.9
S1S 10L — 1212F	10	[Profile-shifted]	φ12.66	L2	12	-	φ12.66	L16 R32	60	-	-	-	56.4
S1S 12K * 1206	12	φ12	φ14	K2	12	φ6(H8)	φ14	18	30	-	2-M4	5	25.1
S1S 13K * 1206	13	φ13	φ15	K2	12	φ6(H8)	φ15	18	30	-	2-M4	5	30.1
S1S 14A — 0805F	14	φ14	φ16	A1	8	φ5	-	-	8	-	-	-	8.4
S1S 14A — 0806	14	φ14	φ16	A1	8	φ6	-	-	8	-	-	-	7.9
S1S 14A — 1206	14	φ14	φ16	A1	12	φ6	-	-	12	-	-	-	11.8
S1S 14B — 0805	14	φ14	φ16	B1	8	φ5(H8)	φ11	8	16	-	-	-	13.0
S1S 14K * 0806	14	φ14	φ16	K2	8	φ6(H8)	φ16	17	25	-	2-M4	4	30.1
S1S 14K * 1206	14	φ14	φ16	K2	12	φ6(H8)	φ16	18	30	-	2-M5	5	35.0
S1S 15A — 0805F	15	φ15	φ17	A1	8	φ5	-	-	8	-	-	-	9.9
S1S 15A — 0806	15	φ15	φ17	A1	8	φ6	-	-	8	-	-	-	9.3
S1S 15A — 1206	15	φ15	φ17	A1	12	φ6	-	-	12	-	-	-	14.0
S1S 15B — 0805	15	φ15	φ17	B1	8	φ5(H8)	φ12	8	16	-	-	-	15.7
S1S 15B — 1005	15	φ15	φ17	B1	10	φ5(H8)	φ12	10	20	-	-	-	19.68
S1S 15K * 0806	15	φ15	φ17	K2	8	φ6(H8)	φ17	17	25	-	2-M4	4	35.0
S1S 15K * 1206	15	φ15	φ17	K2	12	φ6(H8)	φ17	18	30	-	2-M5	5	40.7
S1S 16A — 0805F	16	φ16	φ18	A1	8	φ5	-	-	8	-	-	-	11.4
S1S 16A — 0806	16	φ16	φ18	A1	8	φ6	-	-	8	-	-	-	10.9
S1S 16A — 1208	16	φ16	φ18	A1	12	φ8	-	-	12	-	-	-	14.2
S1S 16B — 0805	16	φ16	φ18	B1	8	φ5(H8)	φ13	8	16	-	-	-	18.5
S1S 16B — 1005	16	φ16	φ18	B1	10	φ5(H8)	φ13	10	20	-	-	-	23.13
S1S 16K * 0806	16	φ16	φ18	K2	8	φ6(H8)	φ18	17	25	-	2-M4	4	40.0
S1S 16K * 0808	16	φ16	φ18	K2	8	φ8(H8)	φ18	17	25	-	2-M4	4	35.9
S1S 16K * 1208	16	φ16	φ18	K2	12	φ8(H8)	φ18	18	30	-	2-M5	5	41.8
S1S 17A — 0805F	17	φ17	φ19	A1	8	φ5	-	-	8	-	-	-	13.0
S1S 17B — 0805	17	φ17	φ19	B1	8	φ5(H8)	φ14	8	16	-	-	-	21.5
S1S 17K * 0808	17	φ17	φ19	K2	8	φ8(H8)	φ19	17	25	-	2-M4	4	41.3
S1S 17K * 1208	17	φ17	φ19	K2	12	φ8(H8)	φ19	18	30	-	2-M5	5	48.2
S1S 18A — 0805F	18	φ18	φ20	A1	8	φ5	-	-	8	-	-	-	14.8
S1S 18A — 0806	18	φ18	φ20	A1	8	φ6	-	-	8	-	-	-	14.2
S1S 18B * 0806	18	φ18	φ20	B1	8	φ6	φ14	8	16	-	2-M4	4	21.5
S1S 18B — 1006	18	φ18	φ20	B1	10	φ6(H8)	φ15	10	20	-	-	-	29.43
S1S 18B * 1008	18	φ18	φ20	B1	10	φ8	φ15	10	20	-	2-M5	5	25.1
S1S 18K * 1208	18	φ18	φ20	K2	12	φ8(H8)	φ20	18	30	-	2-M4	4	55.6
S1S 19A — 0806F	19	φ19	φ21	A1	8	φ6	-	-	8	-	-	-	16.0
S1S 19A — 1208F	19	φ19	φ21	A1	12	φ8	-	-	12	-	-	-	22.0



2D • 3D CAD

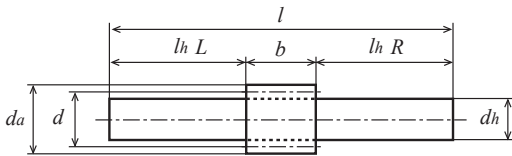

L1 type

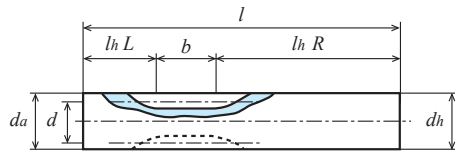

L2 type

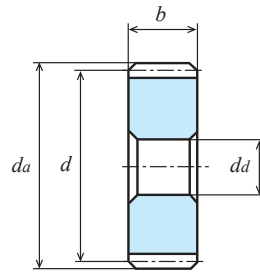

A1 type [-]

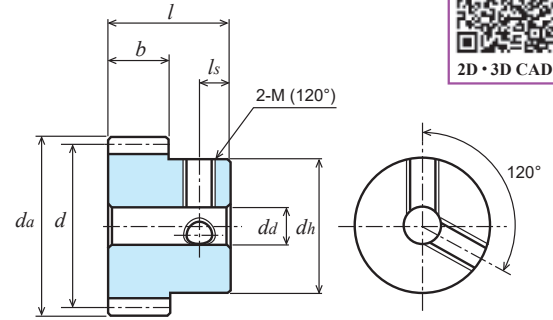

B1 type [\*]

Catalogue number	Number of teeth <i>z</i>	Reference diameter <i>d</i>	Tip diameter <i>da</i>	Type	Face width <i>b</i>	Hole diameter <i>da</i> (H7)	Hub diameter <i>dh</i>	Hub length <i>lh</i>	Overall length <i>l</i>	Key groove <i>b<sub>2</sub> × t<sub>2</sub></i>	Screw		Weight <i>W</i> (g)
											2-M(120°)	<i>ls</i>	
S1S 19B – 0806F	19	φ19	φ21	B1	8	φ6	φ16	8	16	-	-	-	26.9
S1S 20A – 0806F	20	φ20	φ22	A1	8	φ6	-	-	8	-	-	-	18.0
S1S 20A – 0808	20	φ20	φ22	A1	8	φ8	-	-	8	-	-	-	15.0
S1S 20A – 1208F	20	φ20	φ22	A1	12	φ8	-	-	12	-	-	-	24.9
S1S 20A = 1210	20	φ20	φ22	A1	12	φ10	-	-	12	3 × 1.4	-	-	19.2
S1S 20B – 0806F	20	φ20	φ22	B1	8	φ6	φ16	8	16	-	-	-	28.8
S1S 20B * 0806	20	φ20	φ22	B1	8	φ6	φ16	8	16	-	2-M4	4	28.0
S1S 20B * 0808	20	φ20	φ22	B1	8	φ8	φ16	8	16	-	2-M4	4	25.4
S1S 20BF – 1005	20	φ20	φ22	B1	10	φ5(H8)	φ16	10	20	-	-	-	37.0
S1S 20B * 1008	20	φ20	φ22	B1	10	φ8	φ16	10	20	-	2-M5	5	31.5
S1S 20B – 1206F	20	φ20	φ22	B1	12	φ6(H8)	φ16	8	20	-	-	-	37.8
S1S 20B * 1206	20	φ20	φ22	B1	12	φ6(H8)	φ16	8	20	-	2-M4	4	37.0
S1S 20B * 1208	20	φ20	φ22	B1	12	φ8	φ16	8	20	-	2-M4	4	33.7

Number of teeth <i>z</i>	Face width <i>b</i>	Allowable transfer capability table for different revolutions per minute, Bending strength, (Unit: W)							Allowable torque for input revolutions per minute (Unit: N-m)	
		10rpm	100rpm	200rpm	400rpm	800rpm	1,200rpm	1,500rpm	100rpm	
8	12	3.21	32.15	64.29	128.58	257.16	385.74	482.18	3.07	
10	12	4.43	44.29	88.59	177.17	354.34	531.52	664.40	4.22	
12	12	4.07	40.75	81.49	162.99	325.97	488.96	611.20	3.89	
13	12	4.68	46.85	93.69	187.38	374.77	562.15	700.48	4.47	
14	8	3.54	35.41	70.82	141.64	283.28	424.92	523.34	3.38	
14	12	5.31	53.12	106.23	212.46	424.92	637.38	785.01	5.07	
15	8	3.97	39.68	79.37	158.73	317.47	476.20	579.76	3.78	
15	10	4.50	45.03	90.06	180.11	360.22	540.33	675.41	4.30	
15	12	5.95	59.53	119.05	238.10	476.20	714.30	869.64	5.68	
16	8	4.40	44.04	88.08	176.16	352.32	528.05	636.11	4.20	
16	10	5.03	50.26	100.53	201.05	402.11	603.16	753.95	4.80	
16	12	6.61	66.06	132.12	264.24	528.48	792.08	954.16	6.30	
17	8	4.85	48.46	96.92	193.84	387.68	575.64	692.11	4.62	
17	12	7.27	72.69	145.38	290.76	581.53	863.46	1,038.17	6.94	
18	8	5.29	52.94	105.88	217.76	423.52	623.05	747.71	5.06	
18	10	6.62	66.18	132.35	264.7	529.41	778.81	934.63	6.32	
18	12	7.94	79.41	158.82	317.64	635.29	934.57	1,121.56	7.58	
19	8	6.68	66.81	133.62	267.24	534.47	765.05	913.19	6.38	
19	12	10.02	100.21	200.43	400.86	801.71	1,147.57	1,369.79	9.57	
20	8	6.22	62.16	124.32	248.64	497.28	718.27	858.87	5.93	
20	10	7.82	78.22	156.44	312.89	625.78	904.74	1,080.66	7.47	
20	12	9.32	93.24	186.48	372.96	745.92	1,077.41	1,288.30	8.90	

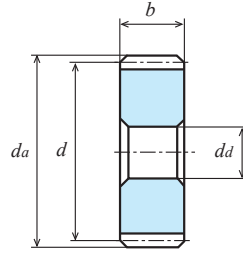
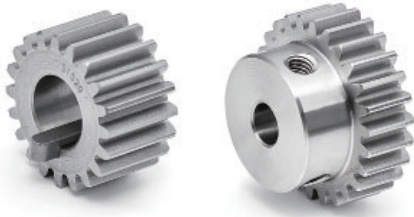

A1 type [-]

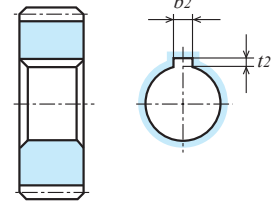

A1 type [=]

Unit: mm

Accuracy Class	Material	Pressure angle	Heat treatment	Tooth surface hardness	Backlash ①
[JIS B 1702-1] N8	S45C	20°	—	—	0.04 to 0.10

★ No surface treatment is applied. [\*] Two screw holes and set screws are provided. Gears with a [=] are provided with key grooves and keys.

★ This allowable transfer capability table was prepared by using the formulas presented by the JGMA (Japan Gear Manufacturers Association). For the unit conversion method, refer to P. 20 in "References."

★ KG standard products have different transfer capabilities depending on whether the face width is "Standard" (for light loads) or "Wide" (for heavy loads).

① This is a theoretical value obtained when a pair of gears of the same type and material are meshed with each other.

Catalogue number	Number of teeth <i>z</i>	Refer-ence diameter <i>d</i>	Tip diameter <i>da</i>	Type	Face width <i>b</i>	Hole diameter <i>da(H7)</i>	Hub diameter <i>dh</i>	Hub length <i>lh</i>	Overall length <i>l</i>	Key groove <i>b<sub>2</sub> × t<sub>2</sub></i>	Screw		Weight <i>W(g)</i>
											2-M(120°)	<i>ls</i>	
S1S 21A — 0806F	21	φ21	φ23	A1	8	φ6	-	-	8	-	-	-	19.1
S1S 21B — 0806F	21	φ21	φ23	B1	8	φ6	φ18	8	16	-	-	-	33.3
S1S 21B — 1208F	21	φ21	φ23	B1	12	φ8	φ18	8	20	-	-	-	48.6
S1S 22A — 0806F	22	φ22	φ24	A1	8	φ6	-	-	8	-	-	-	22.1
S1S 22A — 1210F	22	φ22	φ24	A1	12	φ10	-	-	12	-	-	-	28.4
S1S 22B — 0806F	22	φ22	φ24	B1	8	φ6	φ18	8	16	-	-	-	36.3
S1S 22B — 1208F	22	φ22	φ24	B1	12	φ8	φ18	8	20	-	-	-	43.9
S1S 23A — 0806F	23	φ23	φ25	A1	8	φ6	-	-	8	-	-	-	24.3
S1S 23B — 0806F	23	φ23	φ25	B1	8	φ6	φ20	8	16	-	-	-	42.3
S1S 23B — 1208F	23	φ23	φ25	B1	12	φ8	φ20	8	20	-	-	-	51.0
S1S 24A — 0806F	24	φ24	φ26	A1	8	φ6	-	-	8	-	-	-	26.6
S1S 24A — 0808	24	φ24	φ26	A1	8	φ8	-	-	8	-	-	-	25.3
S1S 24A — 1208F	24	φ24	φ26	A1	12	φ8	-	-	12	-	-	-	37.9
S1S 24A = 1210	24	φ24	φ26	A1	12	φ10	-	-	12	3 × 1.4	-	-	34.8
S1S 24B — 0806	24	φ24	φ26	B1	8	φ6	φ16	8	16	-	-	-	37.5
S1S 24B * 0806	24	φ24	φ26	B1	8	φ6	φ16	8	16	-	2-M4	4	36.7
S1S 24B * 0808	24	φ24	φ26	B1	8	φ8	φ16	8	16	-	2-M4	4	34.1
S1S 24B — 1006	24	φ24	φ26	B1	10	φ6(H8)	φ20	10	20	-	-	-	55.77
S1S 24B * 1008	24	φ24	φ26	B1	10	φ8	φ20	10	20	-	2-M5	5	50.7
S1S 24B — 1208F	24	φ24	φ26	B1	12	φ8	φ20	8	20	-	-	-	54.5
S1S 24B * 1208	24	φ24	φ26	B1	12	φ8	φ20	8	20	-	2-M4	4	53.5
S1S 24B * 1210	24	φ24	φ26	B1	12	φ10	φ20	8	20	-	2-M5	4	48.7
S1S 25A — 0806F	25	φ25	φ27	A1	8	φ6	-	-	8	-	-	-	29.1
S1S 25A — 0808	25	φ25	φ27	A1	8	φ8	-	-	8	-	-	-	27.7
S1S 25A = 0810	25	φ25	φ27	A1	8	φ10	-	-	8	3 × 1.4	-	-	25.6
S1S 25A — 1208F	25	φ25	φ27	A1	12	φ8	-	-	12	-	-	-	41.5
S1S 25A = 1210	25	φ25	φ27	A1	12	φ10	-	-	12	3 × 1.4	-	-	38.5
S1S 25B — 0806	25	φ25	φ27	B1	8	φ6	φ16	8	16	-	-	-	39.9
S1S 25B * 0806	25	φ25	φ27	B1	8	φ6	φ16	8	16	-	2-M4	4	39.1
S1S 25B * 0808	25	φ25	φ27	B1	8	φ8	φ16	8	16	-	2-M4	4	36.5
S1S 25BF — 1005	25	φ25	φ27	B1	10	φ5(H8)	φ20	10	20	-	-	-	59.7
S1S 25B — 1006	25	φ25	φ27	B1	10	φ6(H8)	φ20	10	20	-	-	-	58.79
S1S 25B * 1008	25	φ25	φ27	B1	10	φ8	φ20	10	20	-	2-M5	5	53.8
S1S 25B — 1208F	25	φ25	φ27	B1	12	φ8	φ20	8	20	-	-	-	58.1
S1S 25B * 1208	25	φ25	φ27	B1	12	φ8	φ20	8	20	-	2-M4	4	57.1
S1S 25B * 1210	25	φ25	φ27	B1	12	φ10	φ20	8	20	-	2-M5	4	52.4
S1S 26A — 0806F	26	φ26	φ28	A1	8	φ6	-	-	8	-	-	-	31.6
S1S 26A — 1208F	26	φ26	φ28	A1	12	φ8	-	-	12	-	-	-	45.3
S1S 26B — 0806F	26	φ26	φ28	B1	8	φ6	φ22	8	16	-	-	-	53.7
S1S 26B — 1208F	26	φ26	φ28	B1	12	φ8	φ22	8	20	-	-	-	66.0

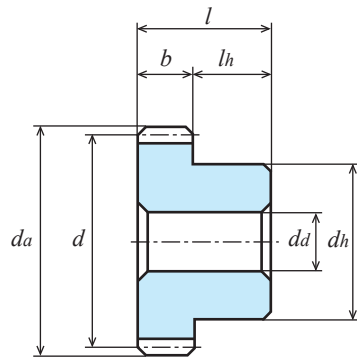

B1 type [-]

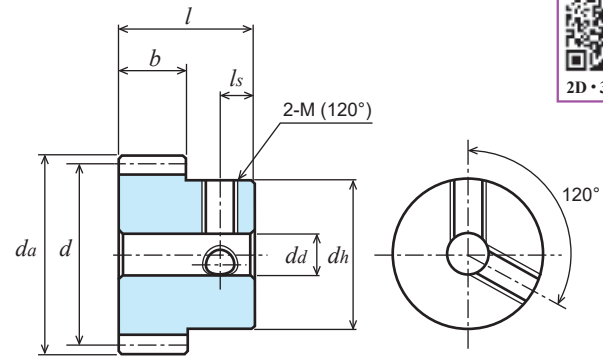

B1 type [\*]

Catalogue number	Number of teeth <i>z</i>	Reference diameter <i>d</i>	Tip diameter <i>d<sub>a</sub></i>	Type	Face width <i>b</i>	Hole diameter <i>d<sub>a</sub></i> (H7)	Hub diameter <i>d<sub>h</sub></i>	Hub length <i>l<sub>h</sub></i>	Overall length <i>l</i>	Key groove <i>b<sub>2</sub> × t<sub>2</sub></i>	Screw		Weight <i>W</i> (g)
											2-M(120°)	<i>l<sub>s</sub></i>	
<b>S1S 27B – 0806F</b>	27	φ27	φ29	B1	8	φ6	φ24	8	16	-	-	-	60.8
<b>S1S 27B – 1208F</b>	27	φ27	φ29	B1	12	φ8	φ24	8	20	-	-	-	74.5
<b>S1S 28A – 0806F</b>	28	φ28	φ30	A1	8	φ6	-	-	8	-	-	-	36.9
<b>S1S 28A – 0808</b>	28	φ28	φ30	A1	8	φ8	-	-	8	-	-	-	35.5
<b>S1S 28B – 0806</b>	28	φ28	φ30	B1	8	φ6	φ20	8	16	-	-	-	54.9
<b>S1S 28B * 0806</b>	28	φ28	φ30	B1	8	φ6	φ20	8	16	-	2-M4	4	53.7
<b>S1S 28B * 0808</b>	28	φ28	φ30	B1	8	φ8	φ20	8	16	-	2-M4	4	51.1
<b>S1S 28B * 0810</b>	28	φ28	φ30	B1	8	φ10	φ20	8	16	-	2-M5	4	52.0
<b>S1S 28B * 1010</b>	28	φ28	φ30	B1	10	φ10	φ24	10	20	-	2-M5	5	69.7
<b>S1S 28B – 1210F</b>	28	φ28	φ30	B1	12	φ10	φ24	8	20	-	-	-	74.1
<b>S1S 28B * 1212</b>	28	φ28	φ30	B1	12	φ12	φ24	8	20	-	2-M5	4	67.1

Number of teeth <i>z</i>	Face width <i>b</i>	Allowable transfer capability table for different revolutions per minute, Bending strength, (Unit: W)							Allowable torque for input revolutions per minute (Unit: N·m)
		10rpm	100rpm	200rpm	400rpm	800rpm	1,200rpm	1,500rpm	100rpm
<b>21</b>	<b>8</b>	6.68	66.81	133.62	267.24	534.47	765.05	913.19	6.38
<b>21</b>	<b>12</b>	10.02	100.21	200.43	400.86	801.71	1,147.57	1,369.79	9.56
<b>22</b>	<b>8</b>	7.15	71.52	143.04	286.09	572.18	811.72	967.23	6.82
<b>22</b>	<b>12</b>	10.73	107.28	214.57	429.13	858.27	1,217.58	1,450.84	10.24
<b>23</b>	<b>8</b>	7.63	76.28	152.56	305.11	610.23	858.05	1,020.71	7.28
<b>23</b>	<b>12</b>	11.44	114.42	228.84	457.67	915.34	1,287.07	1,531.06	10.92
<b>24</b>	<b>8</b>	8.10	81.04	162.07	324.14	647.77	903.58	1,073.09	7.73
<b>24</b>	<b>10</b>	10.13	101.29	202.59	405.18	809.71	1,129.47	1,341.36	9.67
<b>24</b>	<b>12</b>	12.16	121.55	243.11	486.21	971.65	1,355.36	1,609.63	11.60
<b>25</b>	<b>8</b>	8.59	85.86	171.72	343.43	682.04	949.04	1,125.25	8.19
<b>25</b>	<b>10</b>	10.78	107.75	215.50	431.01	855.31	1,189.99	1,412.09	10.29
<b>25</b>	<b>12</b>	12.88	128.79	257.57	515.15	1,023.05	1,423.56	1,687.87	12.29
<b>26</b>	<b>8</b>	9.07	90.71	181.43	362.85	716.14	994.08	1,176.77	8.66
<b>26</b>	<b>12</b>	13.61	136.07	272.14	544.28	1,074.21	1,491.12	1,765.15	12.99
<b>27</b>	<b>8</b>	9.56	95.60	191.20	382.40	750.06	1,038.69	1,227.65	9.12
<b>27</b>	<b>12</b>	14.34	143.40	286.80	573.60	1,125.09	1,558.03	1,841.47	13.69
<b>28</b>	<b>8</b>	10.05	100.52	201.03	402.06	783.81	1,082.86	1,277.89	9.59
<b>28</b>	<b>10</b>	12.56	125.65	251.29	502.58	979.76	1,353.58	1,597.36	11.99
<b>28</b>	<b>12</b>	15.08	150.77	301.55	603.10	1,175.71	1,624.29	1,916.83	14.39

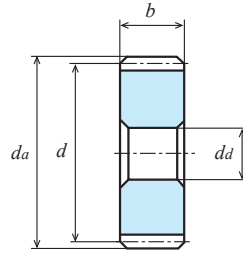
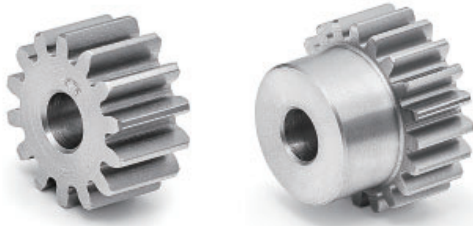

A1 type [-]

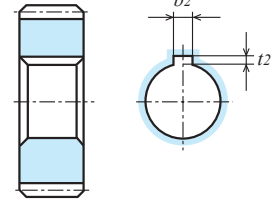

A1 type [=]

Unit: mm

Accuracy Class	Material	Pressure angle	Heat treatment	Tooth surface hardness	Backlash ①
[JIS B 1702-1] N8	S45C	20°	—	—	0.04 to 0.10

★ No surface treatment is applied. [\*] Two screw holes and set screws are provided. Gears with a [=] are provided with key grooves and keys.

★ This allowable transfer capability table was prepared by using the formulas presented by the JGMA (Japan Gear Manufacturers Association). For the unit conversion method, refer to P. 20 in "References."

★ KG standard products have different transfer capabilities depending on whether the face width is "Standard" (for light loads) or "Wide" (for heavy loads).

① This is a theoretical value obtained when a pair of gears of the same type and material are meshed with each other.

Catalogue number	Number of teeth <i>z</i>	Refer-ence diameter <i>d</i>	Tip diameter <i>da</i>	Type	Face width <i>b</i>	Hole diameter <i>da(H7)</i>	Hub diameter <i>d<sub>h</sub></i>	Hub length <i>l<sub>h</sub></i>	Overall length <i>l</i>	Key groove <i>b<sub>2</sub> × t<sub>2</sub></i>	Screw		Weight <i>W(g)</i>
											2-M(120°)	<i>l<sub>s</sub></i>	
S1S 30A – 0808F	30	φ30	φ32	A1	8	φ 8	-	-	8	-	-	-	41.2
S1S 30A = 1010	30	φ30	φ32	A1	10	φ10	-	-	10	3 × 1.4	-	-	49.0
S1S 30A – 1208F	30	φ30	φ32	A1	12	φ 8	-	-	12	-	-	-	61.9
S1S 30A = 1212	30	φ30	φ32	A1	12	φ12	-	-	12	4 × 1.8	-	-	55.3
S1S 30B – 0806	30	φ30	φ32	B1	8	φ 6	φ24	8	16	-	-	-	69.3
S1S 30B * 0806	30	φ30	φ32	B1	8	φ 6	φ24	8	16	-	2-M4	4	67.8
S1S 30B * 0808	30	φ30	φ32	B1	8	φ 8	φ24	8	16	-	2-M4	4	65.2
S1S 30B * 0810	30	φ30	φ32	B1	8	φ10	φ24	8	16	-	2-M5	4	61.1
S1S 30B * 0812	30	φ30	φ32	B1	8	φ12	φ24	8	16	-	2-M5	4	57.1
S1S 30B * 1010	30	φ30	φ32	B1	10	φ10	φ25	10	20	-	2-M5	5	79.8
S1S 30B – 1210	30	φ30	φ32	B1	12	φ10	φ24	8	20	-	-	-	82.7
S1S 30B * 1210	30	φ30	φ32	B1	12	φ10	φ24	8	20	-	2-M5	4	80.9
S1S 30B * 1212	30	φ30	φ32	B1	12	φ12	φ24	8	20	-	2-M5	4	75.7
S1S 32A – 0608F	32	φ32	φ34	A1	6	φ 8	-	-	6	-	-	-	35.5
S1S 32A – 1008F	32	φ32	φ34	A1	10	φ 8	-	-	10	-	-	-	59.2
S1S 32A = 1012	32	φ32	φ34	A1	10	φ12	-	-	10	4 × 1.8	-	-	53.7
S1S 32B – 0606	32	φ32	φ34	B1	6	φ 6	φ24	10	16	-	-	-	69.9
S1S 32B * 0606	32	φ32	φ34	B1	6	φ 6	φ24	10	16	-	2-M4	4	68.4
S1S 32B * 0608	32	φ32	φ34	B1	6	φ 8	φ24	10	16	-	2-M4	4	65.8
S1S 32B * 0612	32	φ32	φ34	B1	6	φ12	φ24	10	16	-	2-M5	5	57.7
S1S 32B – 1010	32	φ32	φ34	B1	10	φ10	φ24	10	20	-	-	-	86.4
S1S 32B * 1010	32	φ32	φ34	B1	10	φ10	φ24	10	20	-	2-M5	5	84.5
S1S 32B * 1012	32	φ32	φ34	B1	10	φ12	φ24	10	20	-	2-M5	5	79.4
S1S 34A – 0608F	34	φ34	φ36	A1	6	φ 8	-	-	6	-	-	-	40.4
S1S 34A – 1008F	34	φ34	φ36	A1	10	φ 8	-	-	10	-	-	-	67.3
S1S 34B – 0606F	34	φ34	φ36	B1	6	φ 6	φ28	10	16	-	-	-	87.6
S1S 34B – 1010F	34	φ34	φ36	B1	10	φ10	φ28	10	20	-	-	-	107.3
S1S 35A – 0608F	35	φ35	φ37	A1	6	φ 8	-	-	6	-	-	-	43.0
S1S 35A – 1008F	35	φ35	φ37	A1	10	φ 8	-	-	10	-	-	-	71.6
S1S 35B – 0606	35	φ35	φ37	B1	6	φ 6	φ24	10	16	-	-	-	77.3
S1S 35B * 0606	35	φ35	φ37	B1	6	φ 6	φ24	10	16	-	2-M4	4	75.8
S1S 35B * 0608	35	φ35	φ37	B1	6	φ 8	φ24	10	16	-	2-M4	4	73.2
S1S 35B * 0610	35	φ35	φ37	B1	6	φ10	φ24	10	16	-	2-M5	5	69.2
S1S 35B * 0612	35	φ35	φ37	B1	6	φ12	φ24	10	16	-	2-M5	5	65.1
S1S 35B – 1010F	35	φ35	φ37	B1	10	φ10	φ30	10	20	-	-	-	118.7
S1S 35B * 1010	35	φ35	φ37	B1	10	φ10	φ30	10	20	-	2-M5	5	116.1
S1S 35B * 1012	35	φ35	φ37	B1	10	φ12	φ30	10	20	-	2-M5	5	111.0
S1S 35B * 1015	35	φ35	φ37	B1	10	φ15	φ30	10	20	-	2-M5	5	101.4

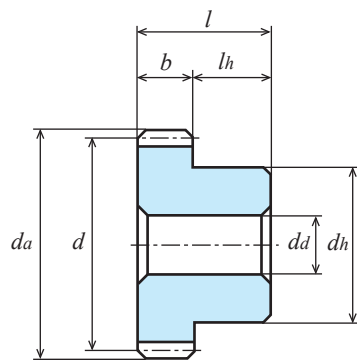

B1 type [-]

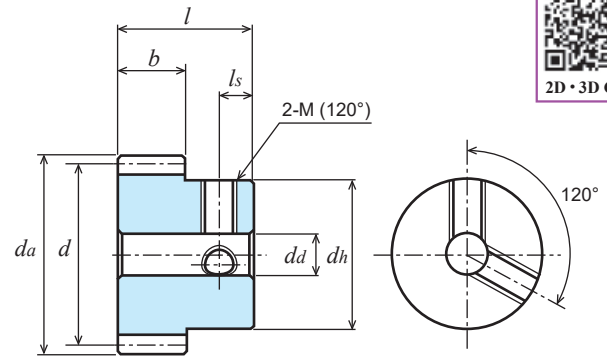

B1 type [\*]

Catalogue number	Number of teeth <i>z</i>	Reference diameter <i>d</i>	Tip diameter <i>da</i>	Type	Face width <i>b</i>	Hole diameter <i>da(H7)</i>	Hub diameter <i>dh</i>	Hub length <i>lh</i>	Overall length <i>l</i>	Key groove <i>b<sub>2</sub> × t<sub>2</sub></i>	Screw		Weight <i>W(g)</i>
											2-M(120°)	<i>ls</i>	
S1S 36A – 0608F	36	φ36	φ38	A1	6	φ 8	-	-	6	-	-	-	45.6
S1S 36A – 1008F	36	φ36	φ38	A1	10	φ 8	-	-	10	-	-	-	76.0
S1S 36A = 1010	36	φ36	φ38	A1	10	φ10	-	-	10	3 × 1.4	-	-	73.4
S1S 36B – 0608	36	φ36	φ38	B1	6	φ 8	φ24	10	16	-	-	-	77.2
S1S 36B * 0608	36	φ36	φ38	B1	6	φ 8	φ24	10	16	-	2-M4	4	75.9
S1S 36B * 0610	36	φ36	φ38	B1	6	φ10	φ24	10	16	-	2-M5	5	71.8
S1S 36B * 0612	36	φ36	φ38	B1	6	φ12	φ24	10	16	-	2-M5	5	67.7
S1S 36B – 1010F	36	φ36	φ38	B1	10	φ10	φ30	10	20	-	-	-	123.1
S1S 36B * 1010	36	φ36	φ38	B1	10	φ10	φ30	10	20	-	2-M5	5	120.5
S1S 36B * 1012	36	φ36	φ38	B1	10	φ12	φ30	10	20	-	2-M5	5	115.4
S1S 36B * 1015	36	φ36	φ38	B1	10	φ15	φ30	10	20	-	2-M5	5	105.8
S1S 38A – 1008F	38	φ38	φ40	A1	10	φ 8	-	-	10	-	-	-	85.1
S1S 38B – 0608F	38	φ38	φ40	B1	6	φ 8	φ25	10	16	-	-	-	85.6
S1S 38B – 1010F	38	φ38	φ40	B1	10	φ10	φ30	10	20	-	-	-	132.2

Number of teeth <i>z</i>	Face width <i>b</i>	Allowable transfer capability table for different revolutions per minute, Bending strength, (Unit: W)							Allowable torque for input revolutions per minute (Unit: N·m)
		10rpm	100rpm	200rpm	400rpm	800rpm	1,200rpm	1,500rpm	100rpm
30	8	11.04	110.37	220.74	441.48	850.22	1,169.22	1,375.68	10.54
30	10	13.81	138.12	276.24	552.48	1,063.91	1,462.66	1,721.52	13.19
30	12	16.56	165.55	331.11	662.22	1,275.33	1,753.83	2,063.52	15.80
32	6	9.03	90.27	180.53	361.07	687.05	940.61	1,103.51	8.62
32	10	15.04	150.45	300.89	601.78	1,145.09	1,567.69	1,839.19	14.36
34	6	9.78	97.82	195.64	391.27	735.73	1,002.88	1,173.30	9.34
34	10	16.30	163.03	326.06	652.12	1,226.22	1,671.47	1,955.49	15.56
35	6	10.16	101.61	203.23	406.46	759.80	1,033.48	1,207.46	9.70
35	10	16.94	169.36	338.72	677.43	1,266.33	1,722.47	2,012.43	16.17
36	6	10.54	105.42	210.85	421.69	783.68	1,063.73	1,241.14	10.06
36	10	17.57	175.71	351.41	702.82	1,306.12	1,772.88	2,068.56	16.77
38	6	11.31	113.08	226.15	452.31	830.87	1,123.15	1,307.07	10.79
38	10	18.85	188.46	376.92	753.85	1,384.78	1,871.91	2,178.45	17.99

- CONTENTS
- INFORMATION
- GEARBOXES
- ANTI-BACKLASH SPUR GEARS
- SPUR GEARS
- RACKS
- HELICAL GEARS AND SCREW GEARS
- MITER GEARS
- BEVEL GEARS
- WORMS AND WORM WHEELS
- REFERENCES



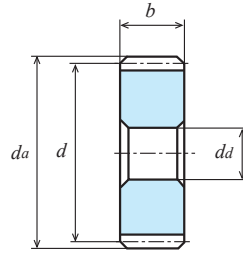
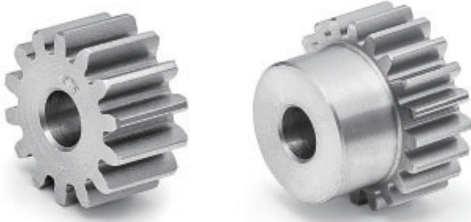

A1 type [-]

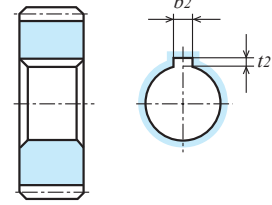

A1 type [=]

Unit: mm

Accuracy Class	Material	Pressure angle	Heat treatment	Tooth surface hardness	Backlash ①
[JIS B 1702-1] N8	S45C	20°	—	—	0.04 to 0.10

★ No surface treatment is applied. [\*] Two screw holes and set screws are provided. Gears with a [=] are provided with key grooves and keys.

★ This allowable transfer capability table was prepared by using the formulas presented by the JGMA (Japan Gear Manufacturers Association). For the unit conversion method, refer to P. 20 in "References."

★ KG standard products have different transfer capabilities depending on whether the face width is "Standard" (for light loads) or "Wide" (for heavy loads).

① This is a theoretical value obtained when a pair of gears of the same type and material are meshed with each other.

Catalogue number	Number of teeth <i>z</i>	Refer-ence diameter <i>d</i>	Tip diameter <i>d<sub>a</sub></i>	Type	Face width <i>b</i>	Hole diameter <i>d<sub>a</sub>(H7)</i>	Hub diameter <i>d<sub>h</sub></i>	Hub length <i>l<sub>h</sub></i>	Overall length <i>l</i>	Key groove <i>b<sub>2</sub> × t<sub>2</sub></i>	Screw		Weight <i>W(g)</i>
											2-M(120°)	<i>l<sub>s</sub></i>	
S1S 40A – 0608F	40	φ40	φ42	A1	6	φ 8	-	-	6	-	-	-	56.8
S1S 40A = 0610	40	φ40	φ42	A1	6	φ10	-	-	6	3 × 1.4	-	-	55.3
S1S 40A = 0612	40	φ40	φ42	A1	6	φ12	-	-	6	4 × 1.8	-	-	53.5
S1S 40A – 1008F	40	φ40	φ42	A1	10	φ 8	-	-	10	-	-	-	94.7
S1S 40A = 1010	40	φ40	φ42	A1	10	φ10	-	-	10	3 × 1.4	-	-	92.2
S1S 40A = 1012	40	φ40	φ42	A1	10	φ12	-	-	10	4 × 1.8	-	-	89.2
S1S 40B – 0608	40	φ40	φ42	B1	6	φ 8	φ24	10	16	-	-	-	88.4
S1S 40B * 0608	40	φ40	φ42	B1	6	φ 8	φ24	10	16	-	2-M4	4	87.1
S1S 40B * 0610	40	φ40	φ42	B1	6	φ10	φ24	10	16	-	2-M5	5	83.1
S1S 40B * 0612	40	φ40	φ42	B1	6	φ12	φ24	10	16	-	2-M5	5	79.0
S1S 40BF – 1006	40	φ40	φ42	B1	10	φ6(H8)	φ30	10	20	-	-	-	149.1
S1S 40B – 1010F	40	φ40	φ42	B1	10	φ10	φ30	10	20	-	-	-	141.8
S1S 40B * 1010	40	φ40	φ42	B1	10	φ10	φ30	10	20	-	2-M5	5	139.3
S1S 40B * 1012	40	φ40	φ42	B1	10	φ12	φ30	10	20	-	2-M5	5	134.1
S1S 40B * 1015	40	φ40	φ42	B1	10	φ15	φ30	10	20	-	2-M5	5	124.5
S1S 42A – 1008F	42	φ42	φ44	A1	10	φ 8	-	-	10	-	-	-	104.8
S1S 42B – 0608F	42	φ42	φ44	B1	6	φ 8	φ28	10	16	-	-	-	107.3
S1S 42B – 1010F	42	φ42	φ44	B1	10	φ10	φ30	10	20	-	-	-	151.9
S1S 44A – 0608F	44	φ44	φ46	A1	6	φ 8	-	-	6	-	-	-	69.3
S1S 44A – 1008F	44	φ44	φ46	A1	10	φ 8	-	-	10	-	-	-	115.4
S1S 44B – 0608F	44	φ44	φ46	B1	6	φ 8	φ28	10	16	-	-	-	113.6
S1S 44B – 1010F	44	φ44	φ46	B1	10	φ10	φ30	10	20	-	-	-	162.5
S1S 45A – 0608F	45	φ45	φ47	A1	6	φ 8	-	-	6	-	-	-	72.5
S1S 45A = 0610	45	φ45	φ47	A1	6	φ10	-	-	6	3 × 1.4	-	-	71.0
S1S 45A – 1008F	45	φ45	φ47	A1	10	φ 8	-	-	10	-	-	-	120.9
S1S 45A = 1015	45	φ45	φ47	A1	10	φ15	-	-	10	5 × 2.3	-	-	110.1
S1S 45B – 0608	45	φ45	φ47	B1	6	φ 8	φ24	10	16	-	-	-	104.2
S1S 45B * 0608	45	φ45	φ47	B1	6	φ 8	φ24	10	16	-	2-M4	4	102.9
S1S 45B * 0610	45	φ45	φ47	B1	6	φ10	φ24	10	16	-	2-M5	5	98.8
S1S 45B * 0612	45	φ45	φ47	B1	6	φ12	φ24	10	16	-	2-M5	5	94.7
S1S 45B – 1010F	45	φ45	φ47	B1	10	φ10	φ30	10	20	-	-	-	168.0
S1S 45B * 1010	45	φ45	φ47	B1	10	φ10	φ30	10	20	-	2-M5	5	165.5
S1S 45B * 1012	45	φ45	φ47	B1	10	φ12	φ30	10	20	-	2-M5	5	160.3
S1S 46A – 1010F	46	φ46	φ48	A1	10	φ10	-	-	10	-	-	-	124.3
S1S 46B – 0608F	46	φ46	φ48	B1	6	φ 8	φ30	10	16	-	-	-	127.5
S1S 46B – 1010F	46	φ46	φ48	B1	10	φ10	φ30	10	20	-	-	-	173.6
S1S 48A – 0608F	48	φ48	φ50	A1	6	φ 8	-	-	6	-	-	-	82.9
S1S 48A = 0610	48	φ48	φ50	A1	6	φ10	-	-	6	3 × 1.4	-	-	81.3
S1S 48A = 0612	48	φ48	φ50	A1	6	φ12	-	-	6	4 × 1.8	-	-	79.6
S1S 48A – 1010F	48	φ48	φ50	A1	10	φ10	-	-	10	-	-	-	135.9
S1S 48A = 1015	48	φ48	φ50	A1	10	φ15	-	-	10	5 × 2.3	-	-	127.3



2D • 3D CAD

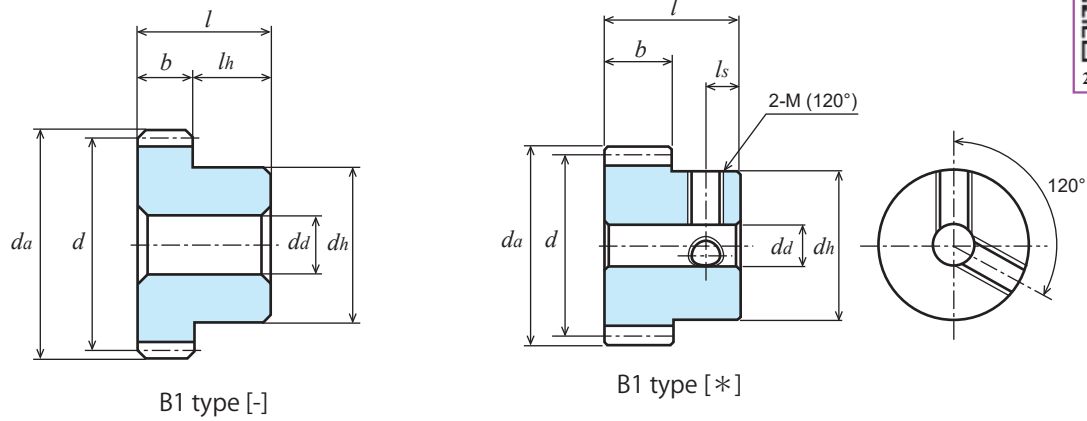

B1 type [-]

B1 type [\*]

Catalogue number	Number of teeth <i>z</i>	Reference diameter <i>d</i>	Tip diameter <i>da</i>	Type	Face width <i>b</i>	Hole diameter <i>da(H7)</i>	Hub diameter <i>d<sub>h</sub></i>	Hub length <i>l<sub>h</sub></i>	Overall length <i>l</i>	Key groove <i>b<sub>2</sub> × t<sub>2</sub></i>	Screw		Weight <i>W(g)</i>
											2-M(120°)	<i>l<sub>s</sub></i>	
S1S 48B – 0608	48	φ48	φ50	B1	6	φ 8	φ24	10	16	-	-	-	114.5
S1S 48B * 0608	48	φ48	φ50	B1	6	φ 8	φ24	10	16	-	2-M4	4	113.2
S1S 48B * 0610	48	φ48	φ50	B1	6	φ10	φ24	10	16	-	2-M5	5	109.1
S1S 48B – 1010	48	φ48	φ50	B1	10	φ10	φ30	10	20	-	-	-	185.3
S1S 48B * 1012	48	φ48	φ50	B1	10	φ12	φ30	10	20	-	2-M5	5	177.5
S1S 48B * 1015	48	φ48	φ50	B1	10	φ15	φ30	10	20	-	2-M5	5	167.9
S1S 50A – 0610F	50	φ50	φ52	A1	6	φ10	-	-	6	-	-	-	88.8
S1S 50A – 1008F	50	φ50	φ52	A1	10	φ 8	-	-	10	-	-	-	150.2
S1S 50B – 0608	50	φ50	φ52	B1	6	φ 8	φ24	10	16	-	-	-	121.8
S1S 50B * 0608	50	φ50	φ52	B1	6	φ 8	φ24	10	16	-	2-M4	4	120.4
S1S 50B * 0610	50	φ50	φ52	B1	6	φ10	φ24	10	16	-	2-M5	5	116.4
S1S 50B * 0612	50	φ50	φ52	B1	6	φ12	φ24	10	16	-	2-M5	5	112.3
S1S 50B – 1010	50	φ50	φ52	B1	10	φ10	φ30	10	20	-	-	-	197.4
S1S 50B * 1010	50	φ50	φ52	B1	10	φ10	φ30	10	20	-	2-M5	5	194.8
S1S 50B * 1012	50	φ50	φ52	B1	10	φ12	φ30	10	20	-	2-M5	5	189.6
S1S 50B * 1015	50	φ50	φ52	B1	10	φ15	φ30	10	20	-	2-M5	5	180.0

Number of teeth <i>z</i>	Face width <i>b</i>	Allowable transfer capability table for different revolutions per minute, Bending strength, (Unit: W)							Allowable torque for input revolutions per minute (Unit: N·m)
		10rpm	100rpm	200rpm	400rpm	800rpm	1,200rpm	1,500rpm	100rpm
40	6	12.08	120.78	241.55	483.10	877.30	1,181.18	1,386.01	11.53
40	10	20.08	200.84	401.69	803.38	1,459.31	1,964.04	2,304.26	19.18
42	6	12.85	128.51	257.02	514.05	922.98	1,237.83	1,465.99	12.27
42	10	21.42	214.19	428.37	856.75	1,538.29	2,063.06	2,443.32	20.45
44	6	13.62	136.19	272.39	544.77	967.23	1,292.26	1,544.38	13.00
44	10	22.70	226.99	453.98	907.95	1,612.04	2,153.77	2,573.97	21.67
45	6	14.01	140.08	280.17	560.34	989.34	1,319.35	1,583.81	13.37
45	10	23.35	233.47	466.95	933.89	1,648.90	2,198.92	2,639.68	22.29
46	6	14.40	143.98	287.96	575.93	1,011.26	1,346.11	1,623.07	13.74
46	10	24.00	239.97	479.94	959.88	1,685.44	2,243.51	2,705.12	22.91
48	6	15.0	150.0	300.0	600.0	1,050.0	1,400.0	1,700.0	14.32
48	10	25.0	250.0	500.0	1,010.0	1,750.0	2,330.0	2,830.0	23.87
50	6	15.00	150.00	310.00	630.00	1,090.00	1,460.00	1,770.00	14.32
50	10	26.00	260.00	530.00	1,050.00	1,820.00	2,430.00	2,950.00	24.83

- CONTENTS
- INFORMATION
- GEARBOXES
- ANTI-BACKLASH SPUR GEARS
- SPUR GEARS
- RACKS
- HELICAL GEARS AND SCREW GEARS
- MITER GEARS
- BEVEL GEARS
- WORMS AND WORM WHEELS
- REFERENCES

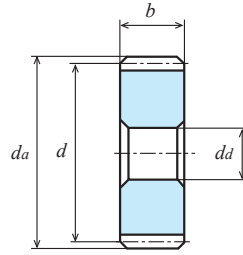
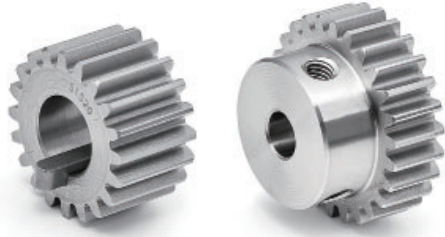

A1 type [-]

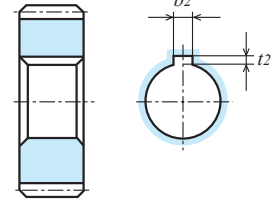

A1 type [=]

Unit: mm

Accuracy Class	Material	Pressure angle	Heat treatment	Tooth surface hardness	Backlash ①
[JIS B 1702-1] N8	S45C	20°	—	—	0.04 to 0.10

★ No surface treatment is applied. [\*] Two screw holes and set screws are provided. Gears with a [=] are provided with key grooves and keys.

★ This allowable transfer capability table was prepared by using the formulas presented by the JGMA (Japan Gear Manufacturers Association). For the unit conversion method, refer to P. 20 in "References."

★ KG standard products have different transfer capabilities depending on whether the face width is "Standard" (for light loads) or "Wide" (for heavy loads).

① This is a theoretical value obtained when a pair of gears of the same type and material are meshed with each other.

Catalogue number	Number of teeth <i>z</i>	Refer-ence diameter <i>d</i>	Tip diameter <i>da</i>	Type	Face width <i>b</i>	Hole diameter <i>dd</i> (H7)	Hub diameter <i>dh</i>	Hub length <i>lh</i>	Overall length <i>l</i>	Key groove <i>b<sub>2</sub> × t<sub>2</sub></i>	Screw		Weight <i>W</i> (g)
											2-M(120°)	<i>ls</i>	
S1S 52A – 0610F	52	φ52	φ54	A1	6	φ10	-	-	6	-	-	-	96.3
S1S 52A – 1010F	52	φ52	φ54	A1	10	φ10	-	-	10	-	-	-	160.5
S1S 52B – 0610F	52	φ52	φ54	B1	6	φ10	φ40	10	16	-	-	-	188.8
S1S 52B – 1010F	52	φ52	φ54	B1	10	φ10	φ46	10	20	-	-	-	284.8
S1S 54A – 0610F	54	φ54	φ56	A1	6	φ10	-	-	6	-	-	-	104.2
S1S 54A – 1010F	54	φ54	φ56	A1	10	φ10	-	-	10	-	-	-	173.6
S1S 54B – 0610F	54	φ54	φ56	B1	6	φ10	φ40	10	16	-	-	-	196.7
S1S 54B – 1010F	54	φ54	φ56	B1	10	φ10	φ46	10	20	-	-	-	297.9
S1S 55A – 0610F	55	φ55	φ57	A1	6	φ10	-	-	6	-	-	-	108.2
S1S 55B – 1010F	55	φ55	φ57	B1	10	φ10	φ46	10	20	-	-	-	304.6
S1S 56A – 0610F	56	φ56	φ58	A1	6	φ10	-	-	6	-	-	-	112.3
S1S 56A – 1010F	56	φ56	φ58	A1	10	φ10	-	-	10	-	-	-	187.2
S1S 56B – 0610	56	φ56	φ58	B1	6	φ10	φ24	10	16	-	-	-	141.7
S1S 56B * 0610	56	φ56	φ58	B1	6	φ10	φ24	10	16	-	2-M5	5	139.9
S1S 56B * 0612	56	φ56	φ58	B1	6	φ12	φ24	10	16	-	2-M5	5	135.8
S1S 56B – 1010	56	φ56	φ58	B1	10	φ10	φ30	10	20	-	-	-	236.7
S1S 56B * 1010	56	φ56	φ58	B1	10	φ10	φ30	10	20	-	2-M5	5	234.0
S1S 56B * 1015	56	φ56	φ58	B1	10	φ15	φ30	10	20	-	2-M5	5	219.3
S1S 58A – 0610F	58	φ58	φ60	A1	6	φ10	-	-	6	-	-	-	114.6
S1S 58B – 0610F	58	φ58	φ60	B1	6	φ10	φ40	10	16	-	-	-	213.2
S1S 58B – 1010F	58	φ58	φ60	B1	10	φ10	φ50	10	20	-	-	-	361.5
S1S 60A – 0610F	60	φ60	φ62	A1	6	φ10	-	-	6	-	-	-	129.5
S1S 60A – 1010F	60	φ60	φ62	A1	10	φ10	-	-	10	-	-	-	215.8
S1S 60A = 1010	60	φ60	φ62	A1	10	φ10	-	-	10	3 × 1.4	-	-	215.5
S1S 60A = 1012	60	φ60	φ62	A1	10	φ12	-	-	10	4 × 1.8	-	-	212.5
S1S 60A = 1015	60	φ60	φ62	A1	10	φ15	-	-	10	5 × 2.3	-	-	207.2
S1S 60B – 0610	60	φ60	φ62	B1	6	φ10	φ30	10	16	-	-	-	178.9
S1S 60B * 0610	60	φ60	φ62	B1	6	φ10	φ30	10	16	-	2-M5	5	176.3
S1S 60B * 0612	60	φ60	φ62	B1	6	φ12	φ30	10	16	-	2-M5	5	172.2
S1S 60B * 0615	60	φ60	φ62	B1	6	φ15	φ30	10	16	-	2-M5	5	164.6
S1S 60BF – 1008	60	φ60	φ62	B1	10	φ 8	φ42	10	20	-	-	-	321.9
S1S 60B – 1010	60	φ60	φ62	B1	10	φ10	φ30	10	20	-	-	-	265.3
S1S 60B * 1010	60	φ60	φ62	B1	10	φ10	φ30	10	20	-	2-M5	5	262.7
S1S 60B * 1012	60	φ60	φ62	B1	10	φ12	φ30	10	20	-	2-M5	5	257.5
S1S 60B * 1015	60	φ60	φ62	B1	10	φ15	φ30	10	20	-	2-M5	5	247.9

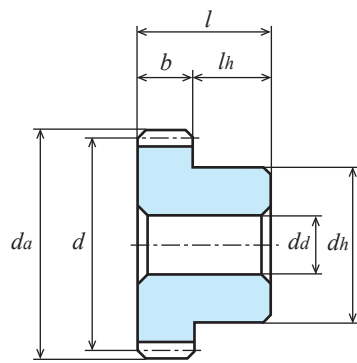

B1 type [-]

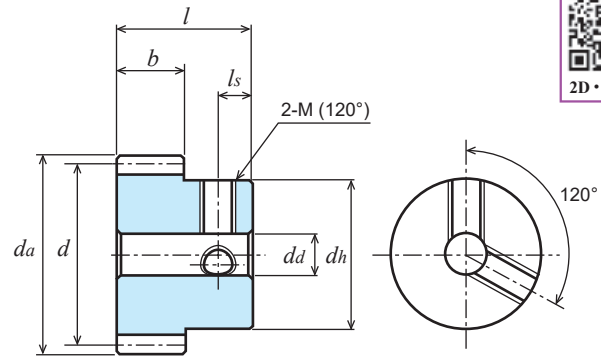

B1 type [\*]

Catalogue number	Number of teeth <i>z</i>	Reference diameter <i>d</i>	Tip diameter <i>da</i>	Type	Face width <i>b</i>	Hole diameter <i>da(H7)</i>	Hub diameter <i>dh</i>	Hub length <i>lh</i>	Overall length <i>l</i>	Key groove <i>b<sub>2</sub> × t<sub>2</sub></i>	Screw		Weight <i>W(g)</i>
											2-M(120°)	<i>ls</i>	
<b>S1S 62A – 0610F</b>	62	φ62	φ64	A1	6	φ10	-	-	6	-	-	-	138.5
<b>S1S 62B – 0610F</b>	62	φ62	φ64	B1	6	φ10	φ40	10	16	-	-	-	231.0
<b>S1S 62B – 1010F</b>	62	φ62	φ64	B1	10	φ10	φ50	10	20	-	-	-	378.8
<b>S1S 64A – 0610F</b>	64	φ64	φ66	A1	6	φ10	-	-	6	-	-	-	147.8
<b>S1S 64A – 1010F</b>	64	φ64	φ66	A1	10	φ10	-	-	10	-	-	-	246.4
<b>S1S 64B – 0610</b>	64	φ64	φ66	B1	6	φ10	φ30	10	16	-	-	-	177.3
<b>S1S 64B * 0610</b>	64	φ64	φ66	B1	6	φ10	φ30	10	16	-	2-M5	5	175.5
<b>S1S 64B * 0612</b>	64	φ64	φ66	B1	6	φ12	φ30	10	16	-	2-M5	5	171.4
<b>S1S 64B – 1010</b>	64	φ64	φ66	B1	10	φ10	φ30	10	20	-	-	-	295.9
<b>S1S 64B * 1010</b>	64	φ64	φ66	B1	10	φ10	φ30	10	20	-	2-M5	5	293.3
<b>S1S 64B * 1015</b>	64	φ64	φ66	B1	10	φ15	φ30	10	20	-	2-M5	5	278.5

Number of teeth <i>z</i>	Face width <i>b</i>	Allowable transfer capability table for different revolutions per minute, Bending strength, (Unit: kW)							Allowable torque for input revolutions per minute (Unit: N-m)
		10rpm	100rpm	200rpm	400rpm	800rpm	1,200rpm	1,500rpm	100rpm
<b>52</b>	<b>6</b>	0.016	0.16	0.33	0.66	1.13	1.53	1.85	15.27
<b>52</b>	<b>10</b>	0.027	0.27	0.55	1.10	1.89	2.55	3.09	25.78
<b>54</b>	<b>6</b>	0.017	0.17	0.35	0.68	1.17	1.59	1.93	16.23
<b>54</b>	<b>10</b>	0.029	0.29	0.58	1.14	1.96	2.65	3.21	27.69
<b>55</b>	<b>6</b>	0.017	0.17	0.35	0.70	1.20	1.62	1.96	16.23
<b>55</b>	<b>10</b>	0.029	0.29	0.59	1.16	2.00	2.71	3.28	27.69
<b>56</b>	<b>6</b>	0.018	0.18	0.36	0.71	1.22	1.65	2.00	17.18
<b>56</b>	<b>10</b>	0.030	0.30	0.61	1.19	2.03	2.76	3.34	28.64
<b>58</b>	<b>6</b>	0.019	0.19	0.38	0.74	1.25	1.72	2.08	18.14
<b>58</b>	<b>10</b>	0.031	0.31	0.63	1.23	2.09	2.87	3.47	29.60
<b>60</b>	<b>6</b>	0.019	0.19	0.39	0.76	1.29	1.78	2.15	18.14
<b>60</b>	<b>10</b>	0.033	0.330	0.660	1.270	2.150	2.960	3.570	31.51
<b>62</b>	<b>6</b>	0.020	0.20	0.41	0.79	1.33	1.84	2.22	19.09
<b>62</b>	<b>10</b>	0.034	0.34	0.69	1.32	2.22	3.08	3.71	32.46
<b>64</b>	<b>6</b>	0.021	0.21	0.43	0.81	1.37	1.91	2.30	20.05
<b>64</b>	<b>10</b>	0.035	0.35	0.71	1.36	2.29	3.18	3.83	33.42

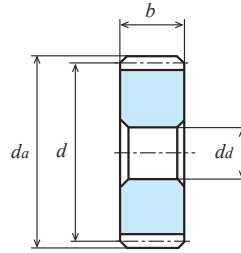

A1 type [-]

Unit: mm

Accuracy Class	Material	Pressure angle	Heat treatment	Tooth surface hardness	Backlash ①
[JIS B 1702-1] N8	S45C	20°	—	—	0.04 to 0.10

★ No surface treatment is applied. [\*] Two screw holes and set screws are provided. Gears with a [-] are provided with key grooves and keys.

★ This allowable transfer capability table was prepared by using the formulas presented by the JGMA (Japan Gear Manufacturers Association). For the unit conversion method, refer to P. 20 in "References."

★ KG standard products have different transfer capabilities depending on whether the face width is "Standard" (for light loads) or "Wide" (for heavy loads).

① This is a theoretical value obtained when a pair of gears of the same type and material are meshed with each other.

Catalogue number	Number of teeth <i>z</i>	Refer- ence diameter <i>d</i>	Tip diameter <i>d<sub>a</sub></i>	Type	Face width <i>b</i>	Hole diameter <i>d<sub>d</sub></i> (H7)	Hub diameter <i>d<sub>h</sub></i>	Hub length <i>l<sub>h</sub></i>	Overall length <i>l</i>	Key groove <i>b<sub>2</sub> × t<sub>2</sub></i>	Screw		Weight <i>W</i> (g)
											2-M(120°)	<i>l<sub>s</sub></i>	
S1S 65A – 0610F	65	φ65	φ67	A1	6	φ10	-	-	6	-	-	-	152.6
S1S 65A – 1010F	65	φ65	φ67	A1	10	φ10	-	-	10	-	-	-	254.3
S1S 65B – 0610F	65	φ65	φ67	B1	6	φ10	φ40	10	16	-	-	-	245.1
S1S 65B – 1010F	65	φ65	φ67	B1	10	φ10	φ50	10	20	-	-	-	402.3
S1S 68A – 0610F	68	φ68	φ70	A1	6	φ10	-	-	6	-	-	-	167.4
S1S 68A – 1010F	68	φ68	φ70	A1	10	φ10	-	-	10	-	-	-	278.9
S1S 68B – 0610F	68	φ68	φ70	B1	6	φ10	φ40	10	16	-	-	-	259.8
S1S 70A – 0610F	70	φ70	φ72	A1	6	φ10	-	-	6	-	-	-	177.6
S1S 70A – 1010F	70	φ70	φ72	A1	10	φ10	-	-	10	-	-	-	295.9
S1S 70B – 0610F	70	φ70	φ72	B1	6	φ10	φ40	10	16	-	-	-	270.0
S1S 70B – 1010F	70	φ70	φ72	B1	10	φ10	φ50	10	20	-	-	-	442.9
S1S 72A – 0610F	72	φ72	φ74	A1	6	φ10	-	-	6	-	-	-	188.1
S1S 72A – 1010F	72	φ72	φ74	A1	10	φ10	-	-	10	-	-	-	313.4
S1S 72B – 0610	72	φ72	φ74	B1	6	φ10	φ30	10	16	-	-	-	217.6
S1S 72B * 0610	72	φ72	φ74	B1	6	φ10	φ30	10	16	-	2-M5	5	215.7
S1S 72B – 1010	72	φ72	φ74	B1	10	φ10	φ30	10	20	-	-	-	363.0
S1S 72B * 1010	72	φ72	φ74	B1	10	φ10	φ30	10	20	-	2-M5	5	360.4
S1S 72B * 1015	72	φ72	φ74	B1	10	φ15	φ30	10	20	-	2-M5	5	345.6
S1S 75A – 0610F	75	φ75	φ77	A1	6	φ10	-	-	6	-	-	-	204.4
S1S 75A – 1010F	75	φ75	φ77	A1	10	φ10	-	-	10	-	-	-	340.6
S1S 75B – 0610F	75	φ75	φ77	B1	6	φ10	φ40	10	16	-	-	-	296.9
S1S 75B – 1010F	75	φ75	φ77	B1	10	φ10	φ50	10	20	-	-	-	488.6
S1S 80A – 0610F	80	φ80	φ82	A1	6	φ10	-	-	6	-	-	-	233.1
S1S 80A – 1010F	80	φ80	φ82	A1	10	φ10	-	-	10	-	-	-	388.4
S1S 80A = 1012	80	φ80	φ82	A1	10	φ12	-	-	10	4 × 1.8	-	-	385.1
S1S 80A = 1015	80	φ80	φ82	A1	10	φ15	-	-	10	5 × 2.3	-	-	379.8
S1S 80B – 0610	80	φ80	φ82	B1	6	φ10	φ30	10	16	-	-	-	282.6
S1S 80B * 0610	80	φ80	φ82	B1	6	φ10	φ30	10	16	-	2-M5	5	279.9
S1S 80B * 0612	80	φ80	φ82	B1	6	φ12	φ30	10	16	-	2-M5	5	275.9
S1S 80B * 0615	80	φ80	φ82	B1	6	φ15	φ30	10	16	-	2-M5	5	268.3
S1S 80BF – 1010	80	φ80	φ82	B1	10	φ10	φ60	10	20	-	-	-	603.1
S1S 80B – 1010	80	φ80	φ82	B1	10	φ10	φ32	10	20	-	-	-	445.7
S1S 80B * 1010	80	φ80	φ82	B1	10	φ10	φ32	10	20	-	2-M5	5	442.8
S1S 80B * 1012	80	φ80	φ82	B1	10	φ12	φ32	10	20	-	2-M5	5	437.6
S1S 80B * 1015	80	φ80	φ82	B1	10	φ15	φ32	10	20	-	2-M5	5	428.0
S1S 80B * 1016	80	φ80	φ82	B1	10	φ16	φ32	10	20	-	2-M5	5	424.3
S1S 84B – 0610F	84	φ84	φ86	B1	6	φ10	φ50	10	16	-	-	-	405.3
S1S 84B – 1010F	84	φ84	φ86	B1	10	φ10	φ50	10	20	-	-	-	576.8



2D • 3D CAD

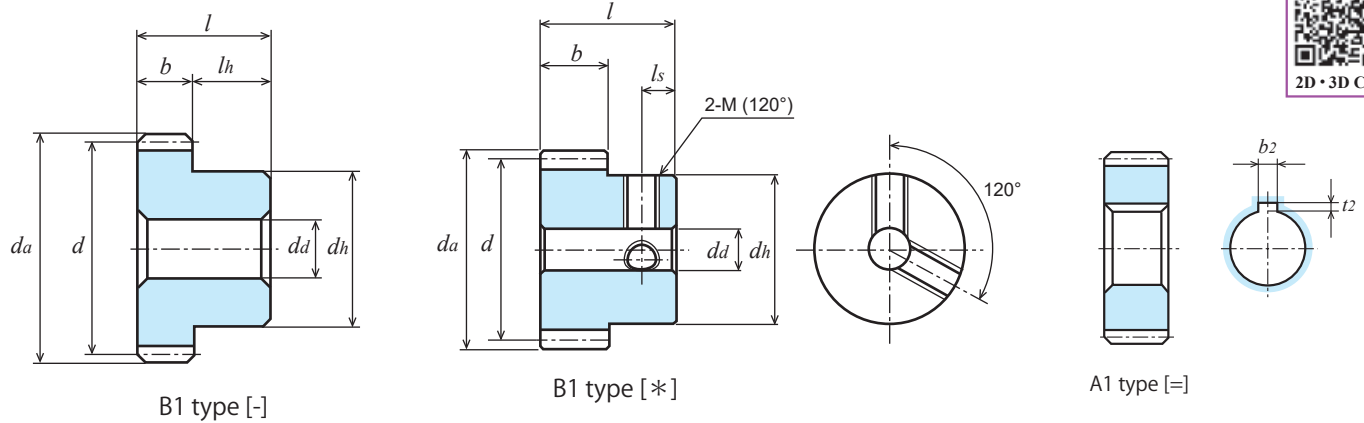

Catalogue number	Number of teeth <i>z</i>	Refer-ence diameter <i>d</i>	Tip diameter <i>d<sub>a</sub></i>	Type	Face width <i>b</i>	Hole diameter <i>d<sub>a</sub>(H7)</i>	Hub diameter <i>d<sub>h</sub></i>	Hub length <i>l<sub>h</sub></i>	Overall length <i>l</i>	Key groove <i>b<sub>2</sub> × t<sub>2</sub></i>	Screw		Weight <i>W(g)</i>
											2-M(120°)	<i>l<sub>s</sub></i>	
<b>S1S 85A – 0610F</b>	85	φ85	φ87	A1	6	φ10	-	-	6	-	-	-	263.6
<b>S1S 85B – 1010F</b>	85	φ85	φ87	B1	10	φ10	φ50	10	20	-	-	-	587.3
<b>S1S 90A – 0610F</b>	90	φ90	φ92	A1	6	φ10	-	-	6	-	-	-	295.9
<b>S1S 90A – 1010F</b>	90	φ90	φ92	A1	10	φ10	-	-	10	-	-	-	493.2
<b>S1S 90B – 0610F</b>	90	φ90	φ92	B1	6	φ10	φ50	10	16	-	-	-	443.9
<b>S1S 90BF – 1010</b>	90	φ90	φ92	B1	10	φ10	φ65	10	20	-	-	-	746.3
<b>S1S 90B – 1010F</b>	90	φ90	φ92	B1	10	φ10	φ50	10	20	-	-	-	641.2

Number of teeth <i>z</i>	Face width <i>b</i>	Allowable transfer capability table for different revolutions per minute, Bending strength, (Unit: kW)							Allowable torque for input revolutions per minute (Unit: N·m)
		10rpm	100rpm	200rpm	400rpm	800rpm	1,200rpm	1,500rpm	100rpm
65	6	0.021	0.21	0.43	0.83	1.39	1.94	2.34	20.05
65	10	0.036	0.36	0.73	1.38	2.32	3.23	3.90	34.37
68	6	0.023	0.23	0.46	0.86	1.44	2.03	2.45	21.96
68	10	0.038	0.38	0.77	1.44	2.41	3.38	4.09	36.28
70	6	0.023	0.23	0.47	0.94	1.48	2.09	2.53	21.96
70	10	0.040	0.400	0.790	1.480	2.460	3.470	4.190	38.20
72	6	0.024	0.24	0.49	0.91	1.52	2.15	2.60	22.91
72	10	0.041	0.41	0.82	1.53	2.53	3.59	4.34	39.15
75	6	0.025	0.25	0.51	0.95	1.58	2.24	2.72	23.87
75	10	0.043	0.43	0.86	1.59	2.64	3.74	4.53	41.06
80	6	0.027	0.27	0.55	1.01	1.69	2.39	2.90	25.78
80	10	0.046	0.460	0.920	1.680	2.810	3.960	4.810	43.93
84	6	0.029	0.29	0.59	1.06	1.78	2.51	3.04	27.69
84	10	0.049	0.49	0.98	1.76	2.96	4.19	5.07	46.79
85	6	0.029	0.29	0.59	1.07	1.80	2.54	3.08	27.69
85	10	0.049	0.49	0.99	1.78	3.00	4.24	5.13	46.79
90	6	0.031	0.31	0.63	1.12	1.90	2.69	3.26	29.60
90	10	0.053	0.530	1.060	1.870	3.160	4.460	5.400	50.61

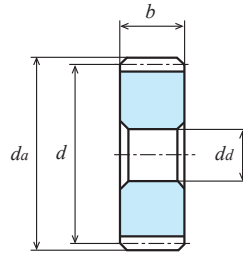

A1 type [-]

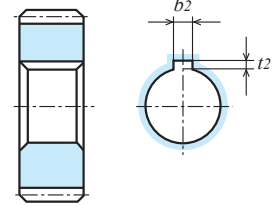

A1 type [=]

Unit: mm

Accuracy Class	Material	Pressure angle	Heat treatment	Tooth surface hardness	Backlash ①
[JIS B 1702-1] N8	S45C	20°	—	—	0.04 to 0.10

★ No surface treatment is applied. [\*] Two screw holes and set screws are provided. Gears with a [=] are provided with key grooves and keys.

★ This allowable transfer capability table was prepared by using the formulas presented by the JGMA (Japan Gear Manufacturers Association). For the unit conversion method, refer to P. 20 in "References."

★ KG standard products have different transfer capabilities depending on whether the face width is "Standard" (for light loads) or "Wide" (for heavy loads).

① This is a theoretical value obtained when a pair of gears of the same type and material are meshed with each other.

Catalogue number	Number of teeth <i>z</i>	Refer-ence diameter <i>d</i>	Tip diameter <i>d<sub>a</sub></i>	Type	Face width <i>b</i>	Hole diameter <i>d<sub>d</sub>(H7)</i>	Hub diameter <i>d<sub>h</sub></i>	Hub length <i>l<sub>h</sub></i>	Overall length <i>l</i>	Key groove <i>b<sub>2</sub> × t<sub>2</sub></i>	Screw		Weight <i>W(g)</i>
											2-M(120°)	<i>l<sub>s</sub></i>	
<b>S1S 96A – 0610F</b>	96	φ 96	φ 98	A1	6	φ10	-	-	6	-	-	-	337.2
<b>S1S 96A – 1010F</b>	96	φ 96	φ 98	A1	10	φ10	-	-	10	-	-	-	562.0
<b>S1S 96B – 0610F</b>	96	φ 96	φ 98	B1	6	φ10	φ50	10	16	-	-	-	485.2
<b>S1S 96B – 1010F</b>	96	φ 96	φ 98	B1	10	φ10	φ50	10	20	-	-	-	710.0
<b>S1S 100A – 0610F</b>	100	φ100	φ102	A1	6	φ10	-	-	6	-	-	-	366.2
<b>S1S 100A = 0612</b>	100	φ100	φ102	A1	6	φ12	-	-	6	4 × 1.8	-	-	364.3
<b>S1S 100A – 1010F</b>	100	φ100	φ102	A1	10	φ10	-	-	10	-	-	-	610.4
<b>S1S 100B – 0610</b>	100	φ100	φ102	B1	6	φ10	φ30	10	16	-	-	-	415.8
<b>S1S 100B * 0610</b>	100	φ100	φ102	B1	6	φ10	φ30	10	16	-	2-M5	5	413.2
<b>S1S 100B * 0612</b>	100	φ100	φ102	B1	6	φ12	φ30	10	16	-	2-M5	5	409.1
<b>S1S 100B * 0615</b>	100	φ100	φ102	B1	6	φ15	φ30	10	16	-	2-M5	5	401.5
<b>S1S 100B – 1012</b>	100	φ100	φ102	B1	10	φ12	φ36	10	20	-	-	-	679.1
<b>S1S 100B * 1015</b>	100	φ100	φ102	B1	10	φ15	φ36	10	20	-	2-M5	5	666.4
<b>S1S 105A – 1010F</b>	105	φ105	φ107	A1	10	φ10	-	-	10	-	-	-	673.6
<b>S1S 110A – 0610F</b>	110	φ110	φ112	A1	6	φ10	-	-	6	-	-	-	443.9
<b>S1S 110A – 1010F</b>	110	φ110	φ112	A1	10	φ10	-	-	10	-	-	-	739.8
<b>S1S 110B – 0610F</b>	110	φ110	φ112	B1	6	φ10	φ50	10	16	-	-	-	591.9
<b>S1S 115A – 0610F</b>	115	φ115	φ117	A1	6	φ10	-	-	6	-	-	-	485.5
<b>S1S 120A – 0610F</b>	120	φ120	φ122	A1	6	φ10	-	-	6	-	-	-	529.0
<b>S1S 120A – 1010F</b>	120	φ120	φ122	A1	10	φ10	-	-	10	-	-	-	881.6
<b>S1S 120A = 1012</b>	120	φ120	φ122	A1	10	φ12	-	-	10	4 × 1.8	-	-	878.4
<b>S1S 120B – 0610</b>	120	φ120	φ122	B1	6	φ10	φ30	10	16	-	-	-	578.7
<b>S1S 120B * 0610</b>	120	φ120	φ122	B1	6	φ10	φ30	10	16	-	2-M5	5	576.1
<b>S1S 120B * 0612</b>	120	φ120	φ122	B1	6	φ12	φ30	10	16	-	2-M5	5	572.0
<b>S1S 120B – 1012</b>	120	φ120	φ122	B1	10	φ12	φ36	10	20	-	-	-	950.6
<b>S1S 120B * 1012</b>	120	φ120	φ122	B1	10	φ12	φ36	10	20	-	2-M5	5	947.4
<b>S1S 120B * 1015</b>	120	φ120	φ122	B1	10	φ15	φ36	10	20	-	2-M5	5	937.8
<b>S1S 120B * 1016</b>	120	φ120	φ122	B1	10	φ16	φ36	10	20	-	2-M5	5	934.1



2D • 3D CAD

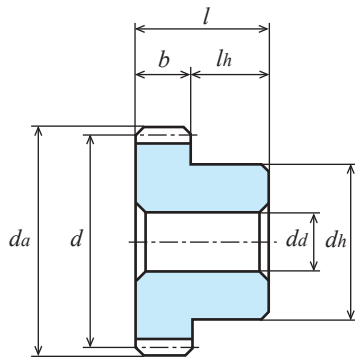

B1 type [-]

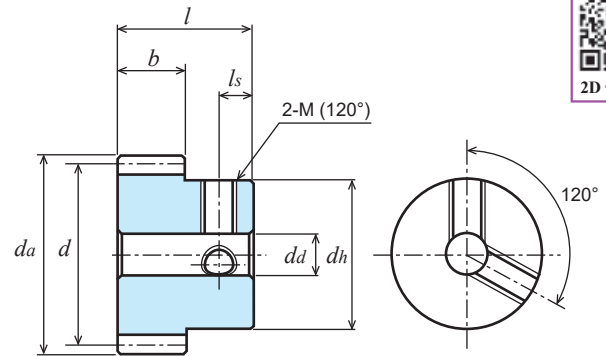

B1 type [\*]

Number of teeth <i>z</i>	Face width <i>b</i>	Allowable transfer capability table for different revolutions per minute, Bending strength, (Unit: kW)							Allowable torque for input revolutions per minute (Unit: N·m)
		10rpm	100rpm	200rpm	400rpm	800rpm	1,200rpm	1,500rpm	100rpm
96	6	0.034	0.34	0.68	1.19	2.03	2.87	3.47	32.46
96	10	0.057	0.57	1.14	1.99	3.39	4.79	5.78	54.43
100	6	0.036	0.36	0.71	1.23	2.11	2.99	3.61	34.37
100	10	0.060	0.600	1.180	2.040	3.500	4.950	5.970	57.30
105	10	0.063	0.63	1.24	2.14	3.70	5.23	6.33	60.16
110	6	0.040	0.40	0.78	1.34	2.32	3.28	4.00	38.19
110	10	0.066	0.66	1.30	2.23	3.87	5.47	6.67	63.02
115	6	0.042	0.42	0.81	1.39	2.42	3.42	4.21	40.10
120	6	0.044	0.44	0.85	1.43	2.52	3.56	4.41	42.01
120	10	0.073	0.730	1.400	2.380	4.160	5.890	7.290	69.71



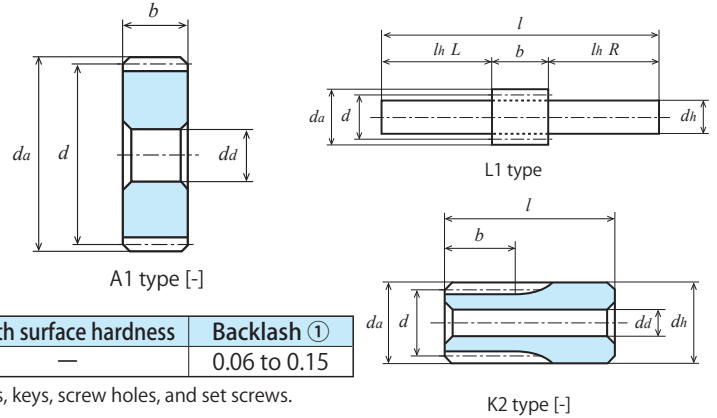
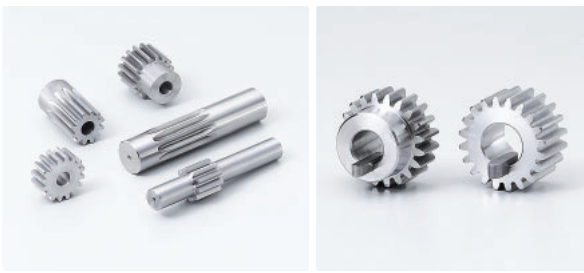

Unit: mm

Accuracy Class	Material	Pressure angle	Heat treatment	Tooth surface hardness	Backlash ①
[JIS B 1702-1] N8	S45C	20°	—	—	0.06 to 0.15

★ No surface treatment is applied. Gears with a [#] are provided with key grooves, keys, screw holes, and set screws.

Gears with a [=] are provided with key grooves and keys.

★ This allowable transfer capability table was prepared by using the formulas presented by the JGMA (Japan Gear Manufacturers Association).

For the unit conversion method, refer to P. 20 in "References."

★ KG standard products have different transfer capabilities depending on whether the face width is "Standard" (for light loads) or "Wide" (for heavy loads).

★ [Profile-shifted] is a profile-shifted gear with a rack shift coefficient  $x$  of 0.5.

① This is a theoretical value obtained when a pair of gears of the same type and material are meshed with each other.

Catalogue number	Number of teeth $z$	Refer-ence diameter $d$	Tip diameter $d_a$	Type	Face width $b$	Hole diameter $da(H7)$	Hub diameter $d_h$	Hub length $l_h$	Overall length $l$	Key groove $b_2 \times t_2$	Screw		Weight $W(g)$
											$M$	$l_s$	
<b>S1.5S 8L – 1809</b>	8	[Profile-shifted] $\phi 15.96$	$\phi 15.96$	L1	18	-	$\phi 9(h9)$	L24 R48	90	-	-	-	56.2
<b>S1.5S 10L – 1812</b>	10	[Profile-shifted] $\phi 19$	$\phi 19$	L1	18	-	$\phi 12(h9)$	L24 R48	90	-	-	-	94.1
<b>S1.5S 12K – 1808</b>	12	$\phi 18$	$\phi 21$	K2	18	$\phi 8(H8)$	$\phi 21$	22	40	-	-	-	80.0
<b>S1.5S 13K – 1808</b>	13	$\phi 19.5$	$\phi 22.5$	K2	18	$\phi 8(H8)$	$\phi 22.5$	22	40	-	-	-	95.1
<b>S1.5S 14K – 1808</b>	14	$\phi 21$	$\phi 24$	K2	18	$\phi 8(H8)$	$\phi 24$	22	40	-	-	-	111.3
<b>S1.5S 15A – 1208</b>	15	$\phi 22.5$	$\phi 25.5$	A1	12	$\phi 8$	-	-	12	-	-	-	32.7
<b>S1.5S 15A – 1808</b>	15	$\phi 22.5$	$\phi 25.5$	A1	18	$\phi 8$	-	-	18	-	-	-	49.1
<b>S1.5S 15B – 1208</b>	15	$\phi 22.5$	$\phi 25.5$	B1	12	$\phi 8$	$\phi 18$	10	22	-	-	-	48.8
<b>S1.5S 15B – 1608N</b>	15	$\phi 22.5$	$\phi 25.5$	B1	16	$\phi 8(H8)$	$\phi 17$	10	26	-	-	-	57.5
<b>S1.5S 16A – 1208</b>	16	$\phi 24$	$\phi 27$	A1	12	$\phi 8$	-	-	12	-	-	-	37.9
<b>S1.5S 16A – 1608</b>	16	$\phi 24$	$\phi 27$	A1	16	$\phi 8$	-	-	16	-	-	-	50.5
<b>S1.5S 16B – 1208</b>	16	$\phi 24$	$\phi 27$	B1	12	$\phi 8$	$\phi 20$	10	22	-	-	-	58.6
<b>S1.5S 16B – 1608N</b>	16	$\phi 24$	$\phi 27$	B1	16	$\phi 8(H8)$	$\phi 18$	10	26	-	-	-	66.6
<b>S1.5S 16B – 1808N</b>	16	$\phi 24$	$\phi 27$	B1	18	$\phi 8(H8)$	$\phi 20$	10	28	-	-	-	77.6
<b>S1.5S 17B – 1208F</b>	17	$\phi 25.5$	$\phi 28.5$	B1	12	$\phi 8$	$\phi 20$	10	22	-	-	-	64.1
<b>S1.5S 17B – 1808</b>	17	$\phi 25.5$	$\phi 28.5$	B1	18	$\phi 8(H8)$	$\phi 20$	10	28	-	-	-	85.8
<b>S1.5S 18A – 1210F</b>	18	$\phi 27$	$\phi 30$	A1	12	$\phi 10$	-	-	12	-	-	-	46.5
<b>S1.5S 18A – 1610F</b>	18	$\phi 27$	$\phi 30$	A1	16	$\phi 10$	-	-	16	-	-	-	62.1
<b>S1.5S 18A – 1810F</b>	18	$\phi 27$	$\phi 30$	A1	18	$\phi 10$	-	-	18	-	-	-	69.8
<b>S1.5S 18B – 1210F</b>	18	$\phi 27$	$\phi 30$	B1	12	$\phi 10$	$\phi 22$	10	22	-	-	-	70.2
<b>S1.5S 18B – 1610</b>	18	$\phi 27$	$\phi 30$	B1	16	$\phi 10$	$\phi 21$	10	26	-	-	-	83.1
<b>S1.5S 18B – 1810</b>	18	$\phi 27$	$\phi 30$	B1	18	$\phi 10$	$\phi 22$	10	28	-	-	-	93.5
<b>S1.5S 19A – 1210F</b>	19	$\phi 28.5$	$\phi 31.5$	A1	12	$\phi 10$	-	-	12	-	-	-	52.7
<b>S1.5S 19B – 1210F</b>	19	$\phi 28.5$	$\phi 31.5$	B1	12	$\phi 10$	$\phi 24$	10	22	-	-	-	82.0
<b>S1.5S 20A – 1010F</b>	20	$\phi 30$	$\phi 33$	A1	10	$\phi 10$	-	-	10	-	-	-	49.3
<b>S1.5S 20A – 1210F</b>	20	$\phi 30$	$\phi 33$	A1	12	$\phi 10$	-	-	12	-	-	-	59.2
<b>S1.5S 20A = 1212</b>	20	$\phi 30$	$\phi 33$	A1	12	$\phi 12$	-	-	12	4 × 1.8	-	-	55.3
<b>S1.5S 20A = 1215</b>	20	$\phi 30$	$\phi 33$	A1	12	$\phi 15$	-	-	12	5 × 2.3	-	-	48.9
<b>S1.5S 20A – 1610F</b>	20	$\phi 30$	$\phi 33$	A1	16	$\phi 10$	-	-	16	-	-	-	78.9
<b>S1.5S 20A – 1810F</b>	20	$\phi 30$	$\phi 33$	A1	18	$\phi 10$	-	-	18	-	-	-	88.8
<b>S1.5S 20A = 1812</b>	20	$\phi 30$	$\phi 33$	A1	18	$\phi 12$	-	-	18	4 × 1.8	-	-	82.9
<b>S1.5S 20B – 1010F</b>	20	$\phi 30$	$\phi 33$	B1	10	$\phi 10$	$\phi 24$	10	20	-	-	-	78.7
<b>S1.5S 20B – 1210F</b>	20	$\phi 30$	$\phi 33$	B1	12	$\phi 10$	$\phi 25$	10	22	-	-	-	91.6
<b>S1.5S 20B # 1212</b>	20	$\phi 30$	$\phi 33$	B1	12	$\phi 12$	$\phi 25$	10	22	4 × 1.8	M3	5	84.2
<b>S1.5S 20B – 1610</b>	20	$\phi 30$	$\phi 33$	B1	16	$\phi 10$	$\phi 24$	10	26	-	-	-	111.4
<b>S1.5S 20B – 1810</b>	20	$\phi 30$	$\phi 33$	B1	18	$\phi 10$	$\phi 25$	10	28	-	-	-	121.2
<b>S1.5S 20B # 1812</b>	20	$\phi 30$	$\phi 33$	B1	18	$\phi 12$	$\phi 25$	10	28	4 × 1.8	M3	5	111.8



2D • 3D CAD

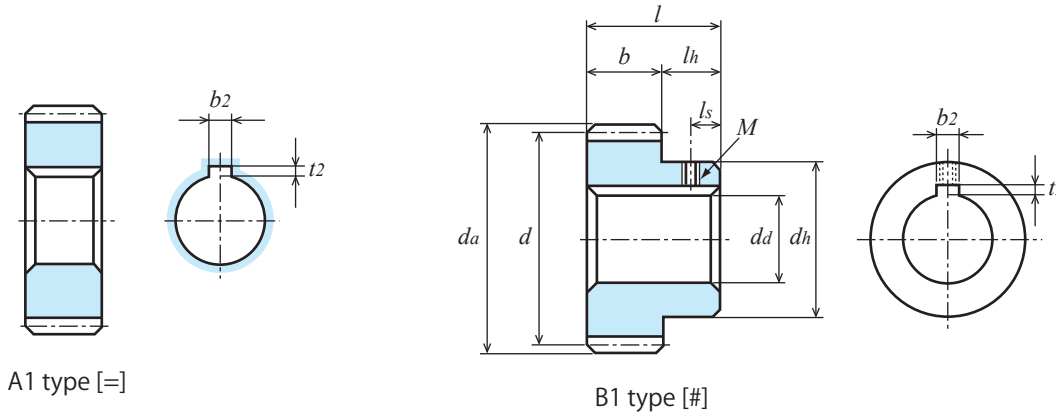

A1 type [=]

B1 type [#]

Catalogue number	Number of teeth <i>z</i>	Reference diameter <i>d</i>	Tip diameter <i>da</i>	Type	Face width <i>b</i>	Hole diameter <i>da</i> (H7)	Hub diameter <i>dh</i>	Hub length <i>lh</i>	Overall length <i>l</i>	Key groove <i>b<sub>2</sub> × t<sub>2</sub></i>	Screw		Weight <i>W</i> (g)
											<i>M</i>	<i>ls</i>	
<b>S1.5S 23B – 1210F</b>	23	φ34.5	φ37.5	B1	12	φ10	φ26	10	22	-	-	-	116.2
<b>S1.5S 24A – 1010F</b>	24	φ36	φ39	A1	10	φ10	-	-	10	-	-	-	73.7
<b>S1.5S 24A – 1210F</b>	24	φ36	φ39	A1	12	φ10	-	-	12	-	-	-	88.5
<b>S1.5S 24A = 1212</b>	24	φ36	φ39	A1	12	φ12	-	-	12	4 × 1.8	-	-	84.6
<b>S1.5S 24A – 1812F</b>	24	φ36	φ39	A1	18	φ12	-	-	18	-	-	-	127.8
<b>S1.5S 24A = 1816</b>	24	φ36	φ39	A1	18	φ16	-	-	18	5 × 2.3	-	-	113.8
<b>S1.5S 24B – 1010F</b>	24	φ36	φ39	B1	10	φ10	φ30	10	20	-	-	-	123.1
<b>S1.5S 24B – 1210F</b>	24	φ36	φ39	B1	12	φ10	φ30	10	22	-	-	-	137.8
<b>S1.5S 24B # 1212</b>	24	φ36	φ39	B1	12	φ12	φ30	10	22	4 × 1.8	M3	5	130.4
<b>S1.5S 24B – 1812</b>	24	φ36	φ39	B1	18	φ12	φ30	10	28	-	-	-	174.6

Number of teeth <i>z</i>	Face width <i>b</i>	Allowable transfer capability table for different revolutions per minute, Bending strength, (Unit: kW)							Allowable torque for input revolutions per minute (Unit: N-m)
		10rpm	100rpm	200rpm	400rpm	800rpm	1,200rpm	1,500rpm	100rpm
8	18	0.010	0.108	0.216	0.433	0.867	1.301	1.619	10.31
10	18	0.014	0.149	0.299	0.598	1.197	1.791	2.156	14.22
12	18	0.013	0.137	0.275	0.550	1.100	1.618	1.942	13.08
13	18	0.015	0.158	0.316	0.632	1.264	1.835	2.196	15.08
14	18	0.017	0.179	0.358	0.717	1.434	2.052	2.450	17.09
15	12	0.013	0.133	0.267	0.535	1.071	1.513	1.801	12.70
15	16	0.017	0.178	0.357	0.714	1.428	2.017	2.402	16.99
15	18	0.020	0.200	0.401	0.803	1.607	2.269	2.702	19.09
16	12	0.014	0.148	0.297	0.594	1.188	1.657	1.968	14.13
16	16	0.019	0.198	0.396	0.792	1.584	2.209	2.624	18.90
16	18	0.022	0.222	0.445	0.891	1.782	2.485	2.952	21.20
17	12	0.016	0.164	0.327	0.654	1.295	1.800	2.133	15.66
17	18	0.024	0.245	0.490	0.981	1.942	2.700	3.198	23.39
18	12	0.017	0.178	0.357	0.714	1.401	1.941	2.294	16.99
18	16	0.023	0.238	0.476	0.952	1.869	2.588	3.059	22.72
18	18	0.026	0.268	0.536	1.072	2.102	2.911	3.441	25.59
19	12	0.019	0.194	0.388	0.776	1.509	2.083	2.456	18.52
20	10	0.017	0.174	0.349	0.699	1.346	1.852	2.179	16.61
20	12	0.020	0.209	0.419	0.839	1.616	2.222	2.614	19.95
20	16	0.027	0.279	0.559	1.118	2.154	2.963	3.486	26.64
20	18	0.031	0.314	0.629	1.258	2.424	3.333	3.922	29.98
23	12	0.025	0.257	0.514	1.029	1.930	2.628	3.073	24.54
24	10	0.022	0.227	0.455	0.911	1.694	2.299	2.683	21.67
24	12	0.027	0.273	0.546	1.093	2.033	2.759	3.219	26.07
24	18	0.041	0.410	0.820	1.640	3.049	4.139	4.829	39.15

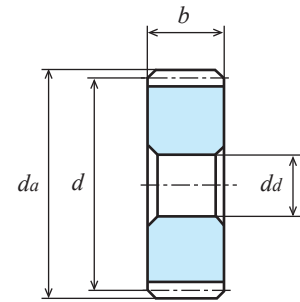
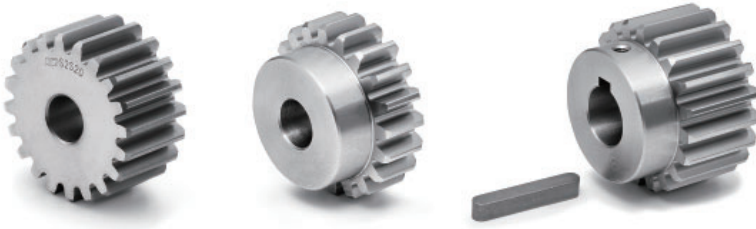

A1 type [-]

Unit: mm

Accuracy Class	Material	Pressure angle	Heat treatment	Tooth surface hardness	Backlash ①
[JIS B 1702-1] N8	S45C	20°	—	—	0.06 to 0.15

★ No surface treatment is applied. Gears with a [#] are provided with key grooves, keys, screw holes, and set screws.

Gears with a [-] are provided with key grooves and keys.

★ This allowable transfer capability table was prepared by using the formulas presented by the JGMA (Japan Gear Manufacturers Association).

For the unit conversion method, refer to P. 20 in "References."

★ KG standard products have different transfer capabilities depending on whether the face width is "Standard" (for light loads) or "Wide" (for heavy loads).

① This is a theoretical value obtained when a pair of gears of the same type and material are meshed with each other.

Catalogue number	Number of teeth <i>z</i>	Refer-ence diameter <i>d</i>	Tip diameter <i>da</i>	Type	Face width <i>b</i>	Hole diameter <i>da(H7)</i>	Hub diameter <i>d<sub>h</sub></i>	Hub length <i>l<sub>h</sub></i>	Overall length <i>l</i>	Key groove <i>b<sub>2</sub> × t<sub>2</sub></i>	Screw		Weight <i>W(g)</i>
											<i>M</i>	<i>l<sub>s</sub></i>	
S1.5S 25A — 1010F	25	φ37.5	φ40.5	A1	10	φ10	-	-	10	-	-	-	80.5
S1.5S 25A — 1210F	25	φ37.5	φ40.5	A1	12	φ10	-	-	12	-	-	-	96.6
S1.5S 25A = 1212	25	φ37.5	φ40.5	A1	12	φ12	-	-	12	4 × 1.8	-	-	92.7
S1.5S 25A = 1816	25	φ37.5	φ40.5	A1	18	φ16	-	-	18	5 × 2.3	-	-	126.0
S1.5S 25B — 1010F	25	φ37.5	φ40.5	B1	10	φ10	φ30	10	20	-	-	-	129.9
S1.5S 25B — 1210	25	φ37.5	φ40.5	B1	12	φ10	φ30	10	22	-	-	-	146.1
S1.5S 25B # 1215	25	φ37.5	φ40.5	B1	12	φ15	φ30	10	22	5 × 2.3	M4	5	126.7
S1.5S 25B — 1612	25	φ37.5	φ40.5	B1	16	φ12	φ30	10	26	-	-	-	171.2
S1.5S 25B — 1812	25	φ37.5	φ40.5	B1	18	φ12	φ32	10	28	-	-	-	194.5
S1.5S 26A — 1210F	26	φ39	φ42	A1	12	φ10	-	-	12	-	-	-	105.1
S1.5S 26A — 1812F	26	φ39	φ42	A1	18	φ12	-	-	18	-	-	-	152.8
S1.5S 26B — 1210F	26	φ39	φ42	B1	12	φ10	φ32	10	22	-	-	-	162.1
S1.5S 26B — 1812	26	φ39	φ42	B1	18	φ12	φ32	10	28	-	-	-	207.2
S1.5S 27A — 1210F	27	φ40.5	φ43.5	A1	12	φ10	-	-	12	-	-	-	114.0
S1.5S 27B — 1210F	27	φ40.5	φ43.5	B1	12	φ10	φ32	10	22	-	-	-	170.9
S1.5S 28A — 1012F	28	φ42	φ45	A1	10	φ12	-	-	10	-	-	-	99.9
S1.5S 28A — 1210F	28	φ42	φ45	A1	12	φ10	-	-	12	-	-	-	123.1
S1.5S 28A — 1612F	28	φ42	φ45	A1	16	φ12	-	-	16	-	-	-	159.8
S1.5S 28A — 1812F	28	φ42	φ45	A1	18	φ12	-	-	18	-	-	-	179.8
S1.5S 28B — 1010F	28	φ42	φ45	B1	10	φ10	φ36	10	20	-	-	-	176.3
S1.5S 28B — 1210	28	φ42	φ45	B1	12	φ10	φ30	10	22	-	-	-	172.5
S1.5S 28B # 1212	28	φ42	φ45	B1	12	φ12	φ30	10	22	4 × 1.8	M3	5	165.0
S1.5S 28B — 1812	28	φ42	φ45	B1	18	φ12	φ36	10	28	-	-	-	251.0
S1.5S 28B # 1815	28	φ42	φ45	B1	18	φ15	φ36	10	28	5 × 2.3	M4	5	233.8
S1.5S 29B — 1812	29	φ43.5	φ46.5	B1	18	φ12	φ38	10	28	-	-	-	274.3
S1.5S 30A — 1012F	30	φ45	φ48	A1	10	φ12	-	-	10	-	-	-	116.0
S1.5S 30A — 1210F	30	φ45	φ48	A1	12	φ10	-	-	12	-	-	-	142.4
S1.5S 30A = 1215	30	φ45	φ48	A1	12	φ15	-	-	12	5 × 2.3	-	-	132.1
S1.5S 30A — 1614F	30	φ45	φ48	A1	16	φ14	-	-	16	-	-	-	180.4
S1.5S 30A — 1814F	30	φ45	φ48	A1	18	φ14	-	-	18	-	-	-	203.0
S1.5S 30A = 1818	30	φ45	φ48	A1	18	φ18	-	-	18	6 × 2.8	-	-	186.4
S1.5S 30B — 1010F	30	φ45	φ48	B1	10	φ10	φ38	10	20	-	-	-	201.5
S1.5S 30B — 1210	30	φ45	φ48	B1	12	φ10	φ30	10	22	-	-	-	191.9
S1.5S 30B # 1212	30	φ45	φ48	B1	12	φ12	φ30	10	22	4 × 1.8	M3	5	184.3
S1.5S 30B # 1215	30	φ45	φ48	B1	12	φ15	φ30	10	22	5 × 2.3	M4	5	172.5
S1.5S 30B — 1612	30	φ45	φ48	B1	16	φ12	φ38	10	26	-	-	-	265.9
S1.5S 30B — 1812	30	φ45	φ48	B1	18	φ12	φ40	10	28	-	-	-	298.7

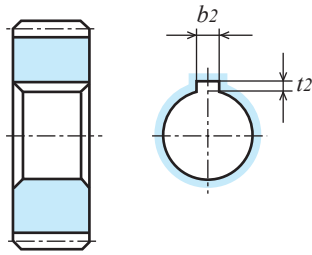

A1 type [=]

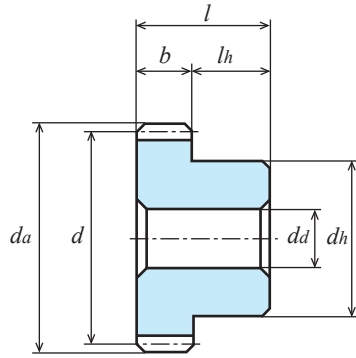

B1 type [-]

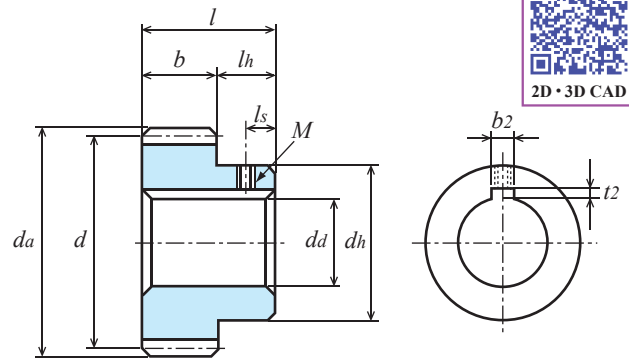

B1 type [#]

Catalogue number	Number of teeth <i>z</i>	Reference diameter <i>d</i>	Tip diameter <i>da</i>	Type	Face width <i>b</i>	Hole diameter <i>da</i> (H7)	Hub diameter <i>dh</i>	Hub length <i>lh</i>	Overall length <i>l</i>	Key groove <i>b<sub>2</sub> × t<sub>2</sub></i>	Screw		Weight <i>W</i> (g)
											<i>M</i>	<i>ls</i>	
<b>S1.5S 32A – 1010F</b>	32	φ48	φ51	A1	10	φ10	-	-	10	-	-	-	135.9
<b>S1.5S 32A – 1614F</b>	32	φ48	φ51	A1	16	φ14	-	-	16	-	-	-	207.9
<b>S1.5S 32B – 1010</b>	32	φ48	φ51	B1	10	φ10	φ30	10	20	-	-	-	185.3
<b>S1.5S 32B – 1612</b>	32	φ48	φ51	B1	16	φ12	φ40	10	26	-	-	-	303.0
<b>S1.5S 34A – 1012F</b>	34	φ51	φ54	A1	10	φ12	-	-	10	-	-	-	151.5
<b>S1.5S 34B – 1010F</b>	34	φ51	φ54	B1	10	φ10	φ44	10	20	-	-	-	267.4
<b>S1.5S 35A – 1614F</b>	35	φ52.5	φ55.5	A1	16	φ14	-	-	16	-	-	-	252.6
<b>S1.5S 35B – 1010F</b>	35	φ52.5	φ55.5	B1	10	φ10	φ44	10	20	-	-	-	277.0

Number of teeth <i>z</i>	Face width <i>b</i>	Allowable transfer capability table for different revolutions per minute, Bending strength, (Unit: kW)							Allowable torque for input revolutions per minute (Unit: N-m)
		10rpm	100rpm	200rpm	400rpm	800rpm	1,200rpm	1,500rpm	
25	10	0.024	0.241	0.482	0.965	1.779	2.407	2.803	23.01
25	12	0.028	0.289	0.579	1.159	2.135	2.889	3.364	27.59
25	16	0.038	0.386	0.772	1.545	2.847	3.852	4.486	36.86
25	18	0.043	0.434	0.869	1.738	3.203	4.334	4.047	41.44
26	12	0.030	0.306	0.612	1.224	2.236	3.017	3.524	29.22
26	18	0.045	0.459	0.918	1.836	3.355	4.526	5.286	43.83
27	12	0.032	0.322	0.645	1.290	2.337	3.143	3.697	30.75
28	10	0.028	0.282	0.565	1.130	2.030	2.722	3.224	26.73
28	12	0.033	0.339	0.678	1.356	2.436	3.267	3.869	32.37
28	16	0.045	0.452	0.904	1.809	3.248	4.356	5.159	43.16
28	18	0.050	0.508	1.017	2.035	3.654	4.901	5.804	48.51
29	18	0.053	0.533	1.067	2.135	3.802	5.084	6.063	50.89
30	10	0.031	0.310	0.620	1.241	2.192	2.923	3.509	29.60
30	12	0.037	0.372	0.744	1.489	2.630	3.508	4.211	35.52
30	16	0.049	0.496	0.993	1.986	3.507	4.677	5.615	47.36
30	18	0.055	0.558	1.117	2.234	3.946	5.262	6.317	53.28
32	10	0.033	0.338	0.677	1.352	2.351	3.122	3.793	32.27
32	16	0.054	0.541	1.083	2.164	3.762	4.996	6.069	51.66
34	10	0.036	0.366	0.733	1.452	2.507	3.359	4.074	34.95
35	10	0.038	0.381	0.762	1.501	2.583	3.477	4.214	36.38
35	16	0.060	0.609	1.219	2.402	4.133	5.563	6.743	58.15

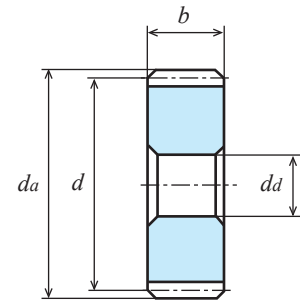
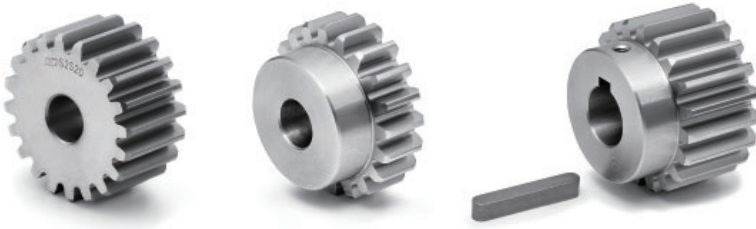

A1 type [-]

Unit: mm

Accuracy Class	Material	Pressure angle	Heat treatment	Tooth surface hardness	Backlash ①
[JIS B 1702-1] N8	S45C	20°	—	—	0.06 to 0.15

★ No surface treatment is applied. Gears with a [#] are provided with key grooves, keys, screw holes, and set screws.

Gears with a [-] are provided with key grooves and keys.

★ This allowable transfer capability table was prepared by using the formulas presented by the JGMA (Japan Gear Manufacturers Association).

For the unit conversion method, refer to P. 20 in "References."

★ KG standard products have different transfer capabilities depending on whether the face width is "Standard" (for light loads) or "Wide" (for heavy loads).

① This is a theoretical value obtained when a pair of gears of the same type and material are meshed with each other.

Catalogue number	Number of teeth <i>z</i>	Refer-ence diameter <i>d</i>	Tip diameter <i>d<sub>a</sub></i>	Type	Face width <i>b</i>	Hole diameter <i>d<sub>d</sub>(H7)</i>	Hub diameter <i>d<sub>h</sub></i>	Hub length <i>l<sub>h</sub></i>	Overall length <i>l</i>	Key groove <i>b<sub>2</sub> × t<sub>2</sub></i>	Screw		Weight <i>W(g)</i>
											<i>M</i>	<i>l<sub>s</sub></i>	
S1.5S 36A – 1012F	36	φ54	φ57	A1	10	φ12	-	-	10	-	-	-	170.9
S1.5S 36A – 1614F	36	φ54	φ57	A1	16	φ14	-	-	16	-	-	-	268.3
S1.5S 36B – 1010	36	φ54	φ57	B1	10	φ10	φ32	10	20	-	-	-	230.7
S1.5S 36B # 1012	36	φ54	φ57	B1	10	φ12	φ32	10	20	4 × 1.8	M3	5	223.8
S1.5S 36B – 1612	36	φ54	φ57	B1	16	φ12	φ40	10	26	-	-	-	363.5
S1.5S 38B – 1012F	38	φ57	φ60	B1	10	φ12	φ50	10	20	-	-	-	336.7
S1.5S 38B – 1612	38	φ57	φ60	B1	16	φ12	φ50	10	26	-	-	-	451.8
S1.5S 40A – 1012F	40	φ60	φ63	A1	10	φ12	-	-	10	-	-	-	213.1
S1.5S 40A = 1016	40	φ60	φ63	A1	10	φ16	-	-	10	5 × 2.3	-	-	205.3
S1.5S 40A – 1614F	40	φ60	φ63	A1	16	φ14	-	-	16	-	-	-	335.8
S1.5S 40B – 1012	40	φ60	φ63	B1	10	φ12	φ36	10	20	-	-	-	284.3
S1.5S 40B # 1015	40	φ60	φ63	B1	10	φ15	φ36	10	20	5 × 2.3	M4	5	271.8
S1.5S 40B # 1018	40	φ60	φ63	B1	10	φ18	φ36	10	20	6 × 2.8	M5	5	258.6
S1.5S 40B – 1612	40	φ60	φ63	B1	16	φ12	φ40	10	26	-	-	-	431.0
S1.5S 42B – 1012F	42	φ63	φ66	B1	10	φ12	φ50	10	20	-	-	-	381.1
S1.5S 42B – 1612	42	φ63	φ66	B1	16	φ12	φ50	10	26	-	-	-	522.9
S1.5S 44A – 1012F	44	φ66	φ69	A1	10	φ12	-	-	10	-	-	-	259.7
S1.5S 44A – 1612F	44	φ66	φ69	A1	16	φ12	-	-	16	-	-	-	415.5
S1.5S 44B – 1012F	44	φ66	φ69	B1	10	φ12	φ50	10	20	-	-	-	404.9
S1.5S 44B – 1612	44	φ66	φ69	B1	16	φ12	φ50	10	26	-	-	-	561.1
S1.5S 45A – 1012F	45	φ67.5	φ70.5	A1	10	φ12	-	-	10	-	-	-	272.0
S1.5S 45B – 1012F	45	φ67.5	φ70.5	B1	10	φ12	φ50	10	20	-	-	-	417.3
S1.5S 46A – 1012F	46	φ69	φ72	A1	10	φ12	-	-	10	-	-	-	284.7
S1.5S 46B – 1012F	46	φ69	φ72	B1	10	φ12	φ50	10	20	-	-	-	429.9
S1.5S 48A – 1014F	48	φ72	φ75	A1	10	φ14	-	-	10	-	-	-	307.5
S1.5S 48A – 1616F	48	φ72	φ75	A1	16	φ16	-	-	16	-	-	-	486.1
S1.5S 48B – 1012	48	φ72	φ75	B1	10	φ12	φ36	10	20	-	-	-	382.0
S1.5S 48B – 1612	48	φ72	φ75	B1	16	φ12	φ40	10	26	-	-	-	587.3
S1.5S 50A – 1014F	50	φ75	φ78	A1	10	φ14	-	-	10	-	-	-	334.7
S1.5S 50A – 1616F	50	φ75	φ78	A1	16	φ16	-	-	16	-	-	-	529.6
S1.5S 50B – 1012	50	φ75	φ78	B1	10	φ12	φ40	10	20	-	-	-	428.0
S1.5S 50B # 1015	50	φ75	φ78	B1	10	φ15	φ40	10	20	5 × 2.3	M4	5	415.3
S1.5S 50B # 1018	50	φ75	φ78	B1	10	φ18	φ40	10	20	6 × 2.8	M5	5	402.1
S1.5S 50B – 1615	50	φ75	φ78	B1	16	φ15	φ50	10	26	-	-	-	673.4



2D • 3D CAD

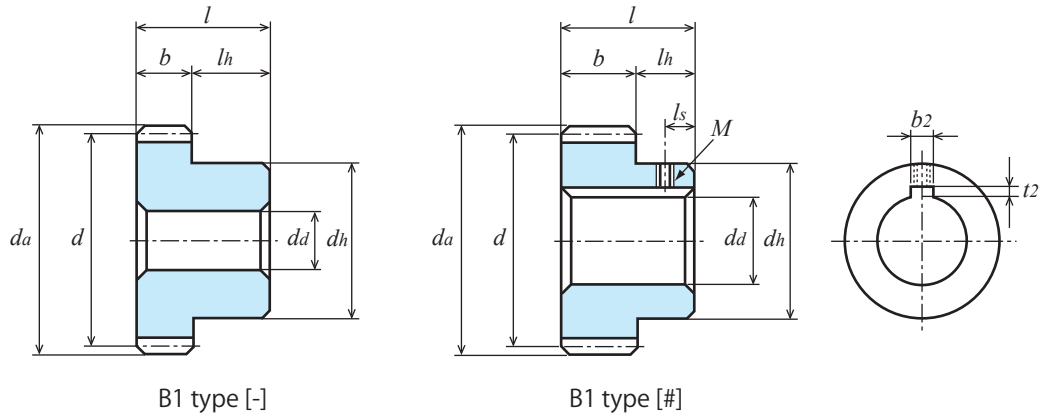

B1 type [-]

B1 type [#]

Catalogue number	Number of teeth <i>z</i>	Refer-ence diameter <i>d</i>	Tip diameter <i>da</i>	Type	Face width <i>b</i>	Hole diameter <i>da(H7)</i>	Hub diameter <i>dh</i>	Hub length <i>lh</i>	Overall length <i>l</i>	Key groove <i>b<sub>2</sub> × t<sub>2</sub></i>	Screw		Weight <i>W(g)</i>
											<i>M</i>	<i>ls</i>	
<b>S1.5S 52A – 1014F</b>	52	φ78	φ81	A1	10	φ14	-	-	10	-	-	-	363.0
<b>S1.5S 52A – 1616F</b>	52	φ78	φ81	A1	16	φ16	-	-	16	-	-	-	574.9
<b>S1.5S 52B – 1616</b>	52	φ78	φ81	B1	16	φ16	φ60	10	26	-	-	-	781.6
<b>S1.5S 54B – 1616</b>	54	φ81	φ84	B1	16	φ16	φ60	10	26	-	-	-	828.7

Number of teeth <i>z</i>	Face width <i>b</i>	Allowable transfer capability table for different revolutions per minute, Bending strength, (Unit: kW)							Allowable torque for input revolutions per minute (Unit: N·m)
		10rpm	100rpm	200rpm	400rpm	800rpm	1,200rpm	1,500rpm	100rpm
36	10	0.039	0.395	0.790	1.550	2.659	3.594	4.353	37.72
36	16	0.063	0.632	1.265	2.481	4.254	5.751	6.966	60.35
38	10	0.042	0.424	0.848	1.648	2.807	3.828	4.629	40.49
38	16	0.067	0.678	1.356	2.637	4.492	6.125	7.407	64.74
40	10	0.045	0.452	0.905	1.744	2.952	4.060	4.902	43.16
40	16	0.072	0.724	1.449	2.791	4.724	6.496	7.844	69.13
42	10	0.048	0.481	0.963	1.839	3.094	4.290	5.173	45.93
42	16	0.077	0.771	1.542	2.943	4.951	6.864	8.276	73.62
44	10	0.051	0.510	1.021	1.932	3.230	4.515	5.448	48.70
44	16	0.080	0.820	1.630	3.090	5.170	7.220	8.720	78.30
45	10	0.052	0.525	1.050	1.978	3.298	4.628	5.588	50.13
46	10	0.053	0.539	1.079	2.024	3.365	4.740	5.727	51.47
48	10	0.05	0.56	1.13	2.11	3.50	4.96	6.00	53.47
48	16	0.09	0.91	1.82	3.39	5.60	7.94	9.61	86.90
50	10	0.059	0.59	1.19	2.20	3.66	5.18	6.28	56.34
50	16	0.096	0.96	1.92	3.53	5.86	8.30	10.05	91.67
52	10	0.062	0.62	1.25	2.29	3.82	5.40	6.55	59.20
52	16	0.101	1.01	2.01	3.67	6.12	8.65	10.49	96.45
54	16	0.105	1.05	2.10	3.81	6.38	9.00	10.92	100.27

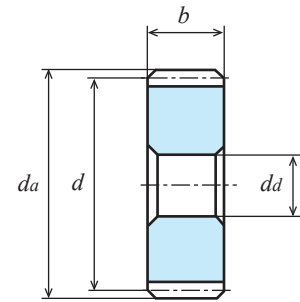
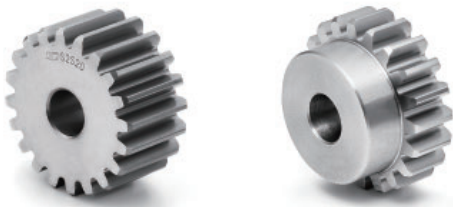

A1 type [-]

Unit: mm

Accuracy Class	Material	Pressure angle	Heat treatment	Tooth surface hardness	Backlash ①
[JIS B 1702-1] N8	S45C	20°	—	—	0.06 to 0.15

★ No surface treatment is applied.

★ This allowable transfer capability table was prepared by using the formulas presented by the JGMA (Japan Gear Manufacturers Association). For the unit conversion method, refer to P. 20 in "References."

★ KG standard products have different transfer capabilities depending on whether the face width is "Standard" (for light loads) or "Wide" (for heavy loads).

① This is a theoretical value obtained when a pair of gears of the same type and material are meshed with each other.

Catalogue number	Number of teeth <i>z</i>	Reference diameter <i>d</i>	Tip diameter <i>d<sub>a</sub></i>	Type	Face width <i>b</i>	Hole diameter <i>d<sub>a</sub>(H7)</i>	Hub diameter <i>d<sub>h</sub></i>	Hub length <i>l<sub>h</sub></i>	Overall length <i>l</i>	Weight <i>W(kg)</i>
<b>S1.5S 55A – 1616F</b>	55	φ 82.5	φ 85.5	A1	16	φ16	-	-	16	0.65
<b>S1.5S 56A – 1616F</b>	56	φ 84	φ 87	A1	16	φ16	-	-	16	0.67
<b>S1.5S 56B – 1616</b>	56	φ 84	φ 87	B1	16	φ16	φ50	10	26	0.81
<b>S1.5S 58B – 1014F</b>	58	φ 87	φ 90	B1	10	φ14	φ50	10	20	0.60
<b>S1.5S 60A – 1014F</b>	60	φ 90	φ 93	A1	10	φ14	-	-	10	0.49
<b>S1.5S 60A – 1616F</b>	60	φ 90	φ 93	A1	16	φ16	-	-	16	0.77
<b>S1.5S 60B – 1014</b>	60	φ 90	φ 93	B1	10	φ14	φ40	10	20	0.57
<b>S1.5S 64A – 1014F</b>	64	φ 96	φ 99	A1	10	φ14	-	-	10	0.56
<b>S1.5S 64B – 1014</b>	64	φ 96	φ 99	B1	10	φ14	φ40	10	20	0.64
<b>S1.5S 68B – 1014F</b>	68	φ102	φ105	B1	10	φ14	φ50	10	20	0.77
<b>S1.5S 70B – 1616</b>	70	φ105	φ108	B1	16	φ16	φ50	10	26	1.20
<b>S1.5S 72A – 1016F</b>	72	φ108	φ111	A1	10	φ16	-	-	10	0.70
<b>S1.5S 72A – 1618F</b>	72	φ108	φ111	A1	16	φ18	-	-	16	1.12
<b>S1.5S 72B – 1016</b>	72	φ108	φ111	B1	10	φ16	φ40	10	20	0.79
<b>S1.5S 75B – 1016F</b>	75	φ112.5	φ115.5	B1	10	φ16	φ50	10	20	0.90
<b>S1.5S 75B – 1618</b>	75	φ112.5	φ115.5	B1	16	φ18	φ60	10	26	1.42
<b>S1.5S 80A – 1618F</b>	80	φ120	φ123	A1	16	φ18	-	-	16	1.39
<b>S1.5S 80B – 1016</b>	80	φ120	φ123	B1	10	φ16	φ40	10	20	0.96
<b>S1.5S 90A – 1622F</b>	90	φ135	φ138	A1	16	φ22	-	-	16	1.75
<b>S1.5S 90B – 1618</b>	90	φ135	φ138	B1	16	φ18	φ70	10	26	2.05
<b>S1.5S 100A – 1016F</b>	100	φ150	φ153	A1	10	φ16	-	-	10	1.37
<b>S1.5S 100A – 1618F</b>	100	φ150	φ153	A1	16	φ18	-	-	16	2.19
<b>S1.5S 100B – 1016</b>	100	φ150	φ153	B1	10	φ16	φ40	10	20	1.46
<b>S1.5S 100B – 1618</b>	100	φ150	φ153	B1	16	φ18	φ50	10	26	2.32



2D • 3D CAD

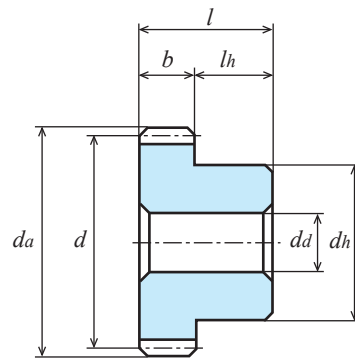

B1 type [-]

Number of teeth <i>z</i>	Face width <i>b</i>	Allowable transfer capability table for different revolutions per minute, Bending strength, (Unit: kW)							Allowable torque for input revolutions per minute (Unit: N·m)
		10rpm	100rpm	200rpm	400rpm	800rpm	1,200rpm	1,500rpm	100rpm
55	16	0.108	1.08	2.15	3.88	6.51	9.18	11.14	103.13
56	16	0.110	1.10	2.20	3.95	6.64	9.37	11.35	105.04
58	10	0.071	0.71	1.43	2.55	4.30	6.07	7.36	67.80
60	10	0.074	0.74	1.49	2.63	4.46	6.30	7.62	70.66
60	16	0.120	1.20	2.39	4.22	7.14	10.09	12.20	114.59
64	10	0.080	0.80	1.61	2.80	4.77	6.74	8.15	76.39
68	10	0.087	0.87	1.72	2.96	5.08	7.19	8.67	83.08
70	16	0.143	1.43	2.83	4.86	8.38	11.85	14.35	136.56
72	10	0.092	0.93	1.82	3.12	5.39	7.62	9.27	88.81
72	16	0.148	1.48	2.91	4.99	8.62	12.19	14.83	141.33
75	10	0.097	0.97	1.89	3.23	5.61	7.94	9.72	92.63
75	16	0.156	1.56	3.03	5.17	8.98	12.71	15.56	148.97
80	10	0.10	1.05	2.02	3.42	5.98	8.47	10.48	100.27
80	16	0.17	1.68	3.23	5.47	9.57	13.55	16.76	160.43
90	16	0.19	1.92	3.61	6.02	10.79	15.34	-	183.35
100	10	0.14	1.35	2.49	4.13	7.49	10.80	-	128.92
100	16	0.22	2.16	3.98	6.61	11.98	17.28	-	206.27



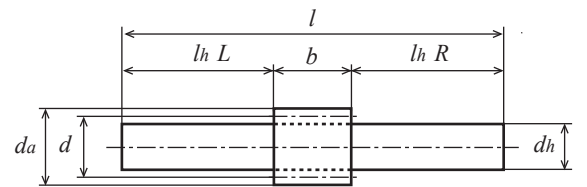

L1 type

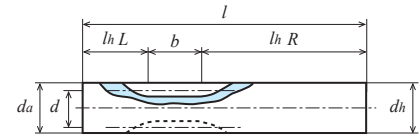

L2 type

Unit: mm

Accuracy Class	Material	Pressure angle	Heat treatment	Tooth surface hardness	Backlash ①
[JIS B 1702-1] N8	S45C	20°	—	—	0.08 to 0.20

★ No surface treatment is applied. Gears with a [#] are provided with key grooves, keys, screw holes, and set screws.  
Gears with a [=] are provided with key grooves and keys.

★ This allowable transfer capability table was prepared by using the formulas presented by the JGMA (Japan Gear Manufacturers Association).  
For the unit conversion method, refer to P. 20 in "References."

★ KG standard products have different transfer capabilities depending on whether the face width is "Standard" (for light loads) or "Wide" (for heavy loads).

★ [Profile-shifted] is a profile-shifted gear with a rack shift coefficient  $x$  of 0.5.

① This is a theoretical value obtained when a pair of gears of the same type and material are meshed with each other.

Catalogue number	Number of teeth $z$	Refer-ence diameter $d$	Tip diameter $d_a$	Type	Face width $b$	Hole diameter $d_d(H7)$	Hub diameter $d_h$	Hub length $l_h$	Overall length $l$	Key groove $b_2 \times t_2$	Screw		Weight $W(g)$
											$M$	$l_s$	
S2S 8L – 2221F	8	[Profile-shifted]	$\phi 21.28$	L2	22	-	$\phi 21.28$	L32 R64	118	-	-	-	312.0
S2S 10L – 2216	10	[Profile-shifted]	$\phi 25.33$	L1	22	-	$\phi 16(h9)$	L32 R64	118	-	-	-	217.2
S2S 12K – 2210	12	$\phi 24$	$\phi 28$	K2	22	$\phi 10(H8)$	$\phi 28$	28	50	-	-	-	182.6
S2S 13K – 2210F	13	$\phi 26$	$\phi 30$	K2	22	$\phi 10(H8)$	$\phi 30$	28	50	-	-	-	216.2
S2S 14A – 1410	14	$\phi 28$	$\phi 32$	A1	14	$\phi 10$	-	-	14	-	-	-	59.0
S2S 14A – 2010	14	$\phi 28$	$\phi 32$	A1	20	$\phi 10$	-	-	20	-	-	-	84.3
S2S 14B – 1410N	14	$\phi 28$	$\phi 32$	B1	14	$\phi 10$	$\phi 22$	10	24	-	-	-	82.8
S2S 14B – 2010N	14	$\phi 28$	$\phi 32$	B1	20	$\phi 10(H8)$	$\phi 22$	10	30	-	-	-	108.1
S2S 15A – 1410	15	$\phi 30$	$\phi 34$	A1	14	$\phi 10$	-	-	14	-	-	-	69.5
S2S 15A – 2010	15	$\phi 30$	$\phi 34$	A1	20	$\phi 10$	-	-	20	-	-	-	98.7
S2S 15A – 2210	15	$\phi 30$	$\phi 34$	A1	22	$\phi 10$	-	-	22	-	-	-	108.5
S2S 15B – 1410N	15	$\phi 30$	$\phi 34$	B1	14	$\phi 10$	$\phi 24$	10	24	-	-	-	98.5
S2S 15B – 2010N	15	$\phi 30$	$\phi 34$	B1	20	$\phi 10(H8)$	$\phi 24$	10	30	-	-	-	128.1
S2S 15B – 2210N	15	$\phi 30$	$\phi 34$	B1	22	$\phi 10(H8)$	$\phi 24$	10	32	-	-	-	138.0
S2S 16A – 1412	16	$\phi 32$	$\phi 36$	A1	14	$\phi 12$	-	-	14	-	-	-	76.0
S2S 16B – 1412N	16	$\phi 32$	$\phi 36$	B1	14	$\phi 12$	$\phi 26$	10	24	-	-	-	108.8
S2S 17B – 2212	17	$\phi 34$	$\phi 38$	B1	22	$\phi 12$	$\phi 28$	10	32	-	-	-	176.8
S2S 18A – 1212F	18	$\phi 36$	$\phi 40$	A1	12	$\phi 12$	-	-	12	-	-	-	85.2
S2S 18A – 1412F	18	$\phi 36$	$\phi 40$	A1	14	$\phi 12$	-	-	14	-	-	-	99.4
S2S 18A – 2012F	18	$\phi 36$	$\phi 40$	A1	20	$\phi 12$	-	-	20	-	-	-	142.1
S2S 18A – 2212F	18	$\phi 36$	$\phi 40$	A1	22	$\phi 12$	-	-	22	-	-	-	156.3
S2S 18A = 2215	18	$\phi 36$	$\phi 40$	A1	22	$\phi 15$	-	-	22	5 × 2.3	-	-	143.3
S2S 18B – 1412	18	$\phi 36$	$\phi 40$	B1	14	$\phi 12$	$\phi 30$	10	24	-	-	-	146.1
S2S 18B # 1415	18	$\phi 36$	$\phi 40$	B1	14	$\phi 15$	$\phi 30$	10	24	5 × 2.3	M4	5	131.6
S2S 19B – 1412	19	$\phi 38$	$\phi 42$	B1	14	$\phi 12$	$\phi 32$	10	24	-	-	-	166.6



2D • 3D CAD

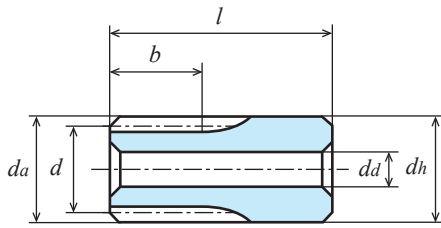

K2 type [-]

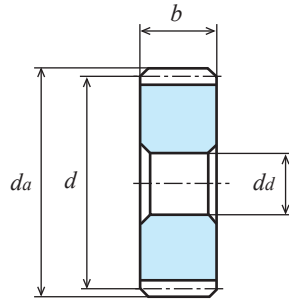

A1 type [-]

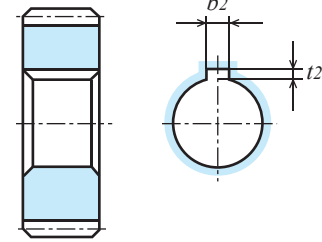

A1 type [=]

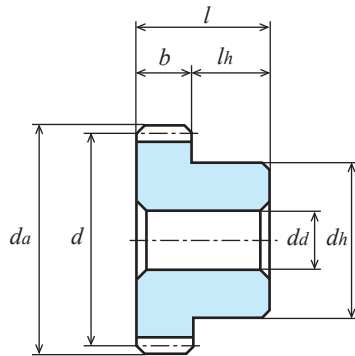

B1 type [-]

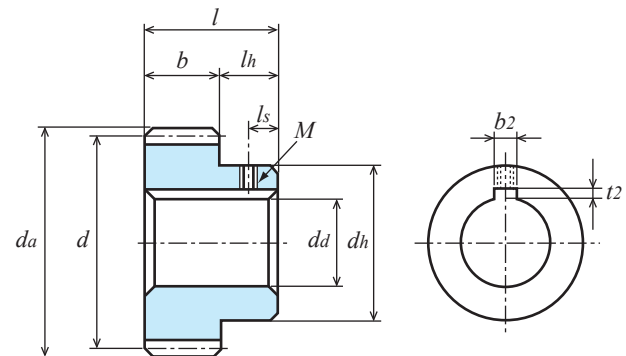

B1 type [#]

Number of teeth <i>z</i>	Face width <i>b</i>	Allowable transfer capability table for different revolutions per minute, Bending strength, (Unit: kW)							Allowable torque for input revolutions per minute (Unit: N·m)
		10rpm	100rpm	200rpm	400rpm	800rpm	1,200rpm	1,500rpm	100rpm
8	22	0.023	0.235	0.471	0.942	1.885	2.785	3.345	22.44
10	22	0.032	0.325	0.650	1.300	2.600	3.702	4.414	31.03
12	22	0.029	0.298	0.597	1.195	2.388	3.331	3.956	28.45
13	22	0.034	0.343	0.687	1.374	2.712	3.764	4.456	32.75
14	14	0.024	0.247	0.495	0.991	1.932	2.670	3.151	23.58
14	20	0.035	0.354	0.708	1.416	2.761	3.814	4.501	33.80
15	14	0.027	0.277	0.555	1.111	2.139	2.942	3.462	26.45
15	20	0.039	0.396	0.793	1.587	3.056	4.203	4.946	37.81
15	22	0.043	0.436	0.873	1.746	3.362	4.624	5.440	41.63
16	14	0.030	0.308	0.616	1.233	2.346	3.212	3.768	29.41
17	22	0.053	0.533	1.066	2.132	4.009	5.465	6.393	50.89
18	12	0.031	0.317	0.635	1.270	2.361	3.205	3.739	30.27
18	14	0.037	0.370	0.741	1.482	2.754	3.739	4.362	35.33
18	20	0.052	0.529	1.058	2.117	3.935	5.341	6.232	50.51
18	22	0.058	0.582	1.164	2.329	4.328	5.875	6.855	55.57
19	14	0.040	0.403	0.806	1.611	2.960	4.001	4.656	38.48

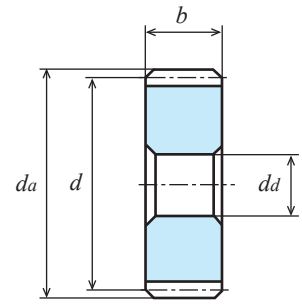
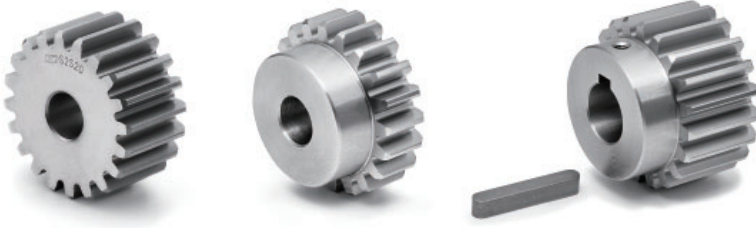

Unit: mm

Accuracy Class	Material	Pressure angle	Heat treatment	Tooth surface hardness	Backlash ①
[JIS B 1702-1] N8	S45C	20°	—	—	0.08 to 0.20

★ No surface treatment is applied. Gears with a [#] are provided with key grooves, keys, screw holes, and set screws.  
Gears with a [=] are provided with key grooves and keys.

★ This allowable transfer capability table was prepared by using the formulas presented by the JGMA (Japan Gear Manufacturers Association).  
For the unit conversion method, refer to P. 20 in "References."

★ KG standard products have different transfer capabilities depending on whether the face width is "Standard" (for light loads) or "Wide" (for heavy loads).

① This is a theoretical value obtained when a pair of gears of the same type and material are meshed with each other.

A1 type [-]

Catalogue number	Number of teeth <i>z</i>	Refer-ence diameter <i>d</i>	Tip diameter <i>d<sub>a</sub></i>	Type	Face width <i>b</i>	Hole diameter <i>d<sub>d</sub>(H7)</i>	Hub diameter <i>d<sub>h</sub></i>	Hub length <i>l<sub>h</sub></i>	Overall length <i>l</i>	Key groove <i>b<sub>2</sub> × t<sub>2</sub></i>	Screw		Weight <i>W(g)</i>
											<i>M</i>	<i>l<sub>s</sub></i>	
S2S 20A – 1212F	20	φ40	φ44	A1	12	φ12	-	-	12	-	-	-	107.7
S2S 20A – 1412F	20	φ40	φ44	A1	14	φ12	-	-	14	-	-	-	125.7
S2S 20A – 2012F	20	φ40	φ44	A1	20	φ12	-	-	20	-	-	-	179.5
S2S 20A – 2212F	20	φ40	φ44	A1	22	φ12	-	-	22	-	-	-	197.5
S2S 20A = 2215	20	φ40	φ44	A1	22	φ15	-	-	22	5 × 2.3	-	-	184.5
S2S 20B – 1212	20	φ40	φ44	B1	12	φ12	φ33	10	22	-	-	-	162.1
S2S 20B – 1412	20	φ40	φ44	B1	14	φ12	φ32	10	24	-	-	-	180.0
S2S 20B # 1415	20	φ40	φ44	B1	14	φ15	φ32	10	24	5 × 2.3	M4	5	165.4
S2S 20BF – 2008	20	φ40	φ44	B1	20	φ8(H8)	φ34	20	40	-	-	-	321.1
S2S 20B – 2012N	20	φ40	φ44	B1	20	φ12	φ34	10	30	-	-	-	242.1
S2S 20B – 2212	20	φ40	φ44	B1	22	φ12	φ34	10	32	-	-	-	260.1
S2S 20B # 2215	20	φ40	φ44	B1	22	φ15	φ34	10	32	5 × 2.3	M4	5	240.6
S2S 20B # 2220	20	φ40	φ44	B1	22	φ20	φ34	10	32	6 × 2.8	M4	5	204.9
S2S 21B – 2212	21	φ42	φ46	B1	22	φ12	φ36	10	32	-	-	-	290.9
S2S 22B – 2212	22	φ44	φ48	B1	22	φ12	φ38	10	32	-	-	-	323.4
S2S 24A – 1214F	24	φ48	φ52	A1	12	φ14	-	-	12	-	-	-	156.0
S2S 24A – 1412F	24	φ48	φ52	A1	14	φ12	-	-	14	-	-	-	186.4
S2S 24A – 2014F	24	φ48	φ52	A1	20	φ14	-	-	20	-	-	-	259.9
S2S 24A – 2214F	24	φ48	φ52	A1	22	φ14	-	-	22	-	-	-	285.9
S2S 24A = 2220	24	φ48	φ52	A1	22	φ20	-	-	22	6 × 2.8	-	-	255.4
S2S 24B – 1214	24	φ48	φ52	B1	12	φ14	φ40	10	22	-	-	-	207.1
S2S 24B – 1414	24	φ48	φ52	B1	14	φ14	φ32	10	24	-	-	-	233.2
S2S 24B – 2014N	24	φ48	φ52	B1	20	φ14	φ42	10	30	-	-	-	356.8
S2S 24B – 2214	24	φ48	φ52	B1	22	φ14	φ40	10	32	-	-	-	372.7
S2S 25A – 1414F	25	φ50	φ54	A1	14	φ14	-	-	14	-	-	-	198.9
S2S 25A = 1416	25	φ50	φ54	A1	14	φ16	-	-	14	5 × 2.3	-	-	192.4
S2S 25A – 2014F	25	φ50	φ54	A1	20	φ14	-	-	20	-	-	-	284.1
S2S 25A – 2214F	25	φ50	φ54	A1	22	φ14	-	-	22	-	-	-	312.5
S2S 25B – 1214	25	φ50	φ54	B1	12	φ14	φ42	10	22	-	-	-	221.7
S2S 25B – 1414	25	φ50	φ54	B1	14	φ14	φ32	10	24	-	-	-	250.1
S2S 25BF – 2008	25	φ50	φ54	B1	20	φ8(H8)	φ40	20	40	-	-	-	486.2
S2S 25B – 2014N	25	φ50	φ54	B1	20	φ14	φ44	10	30	-	-	-	391.6
S2S 25B – 2214	25	φ50	φ54	B1	22	φ14	φ40	10	32	-	-	-	399.3
S2S 25B # 2220	25	φ50	φ54	B1	22	φ20	φ40	10	32	6 × 2.8	M5	5	353.9



2D • 3D CAD

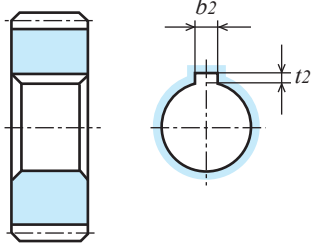

A1 type [=]

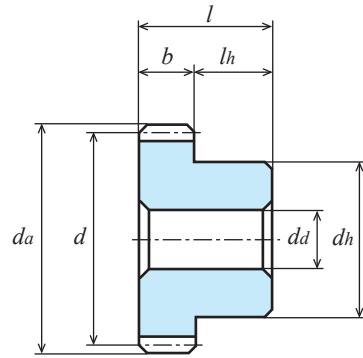

B1 type [-]

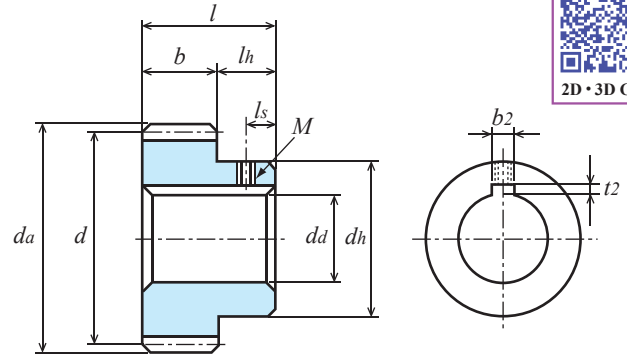

B1 type [#]

Catalogue number	Number of teeth <i>z</i>	Reference diameter <i>d</i>	Tip diameter <i>d<sub>a</sub></i>	Type	Face width <i>b</i>	Hole diameter <i>d<sub>a</sub>(H7)</i>	Hub diameter <i>d<sub>h</sub></i>	Hub length <i>l<sub>h</sub></i>	Overall length <i>l</i>	Key groove <i>b<sub>2</sub> × t<sub>2</sub></i>	Screw		Weight <i>W(g)</i>
											<i>M</i>	<i>l<sub>s</sub></i>	
S2S 28A – 1214F	28	φ56	φ60	A1	12	φ14	-	-	12	-	-	-	217.5
S2S 28A – 1414F	28	φ56	φ60	A1	14	φ14	-	-	14	-	-	-	253.8
S2S 28A = 1415	28	φ56	φ60	A1	14	φ15	-	-	14	5 × 2.3	-	-	250.0
S2S 28A = 1416	28	φ56	φ60	A1	14	φ16	-	-	14	5 × 2.3	-	-	247.3
S2S 28A – 2216F	28	φ56	φ60	A1	22	φ16	-	-	22	-	-	-	390.6
S2S 28B – 1214	28	φ56	φ60	B1	12	φ14	φ48	10	22	-	-	-	304.3
S2S 28B – 1414	28	φ56	φ60	B1	14	φ14	φ40	10	24	-	-	-	340.6
S2S 28B # 1415	28	φ56	φ60	B1	14	φ15	φ40	10	24	5 × 2.3	M4	5	333.3
S2S 28B – 2016N	28	φ56	φ60	B1	20	φ16	φ50	10	30	-	-	-	493.8
S2S 28B – 2216	28	φ56	φ60	B1	22	φ16	φ50	10	32	-	-	-	529.3

Number of teeth <i>z</i>	Face width <i>b</i>	Allowable transfer capability table for different revolutions per minute, Bending strength, (Unit: kW)							Allowable torque for input revolutions per minute (Unit: N·m)
		10rpm	100rpm	200rpm	400rpm	800rpm	1,200rpm	1,500rpm	100rpm
20	12	0.037	0.372	0.745	1.491	2.709	3.647	4.280	35.52
20	14	0.043	0.435	0.870	1.740	3.160	4.255	4.993	41.54
20	20	0.063	0.630	1.250	2.500	4.550	6.120	7.190	60.16
20	22	0.068	0.683	1.367	2.735	4.966	6.687	7.846	65.22
21	22	0.073	0.73	1.47	2.94	5.28	7.08	8.38	69.71
22	22	0.078	0.79	1.57	3.15	5.59	7.47	8.92	75.44
24	12	0.048	0.49	0.97	1.94	3.377	4.49	5.45	46.79
24	14	0.056	0.57	1.14	2.27	3.940	5.23	6.36	54.43
24	20	0.081	0.81	1.62	3.24	5.63	7.48	9.08	77.35
24	22	0.089	0.89	1.78	3.56	6.19	8.22	9.99	84.99
25	12	0.051	0.52	1.03	2.05	3.54	4.73	5.74	49.65
25	14	0.060	0.60	1.20	2.39	4.13	5.52	6.70	57.29
25	20	0.086	0.860	1.720	3.420	5.920	7.910	9.600	82.13
25	22	0.094	0.94	1.89	3.75	6.49	8.67	10.52	89.76
28	12	0.060	0.60	1.21	2.35	4.01	5.46	6.60	57.29
28	14	0.070	0.70	1.41	2.74	4.68	6.37	7.70	66.84
28	20	0.101	1.01	2.01	3.92	6.69	9.10	11.01	96.45
28	22	0.111	1.11	2.21	4.31	7.36	10.01	12.11	106.00

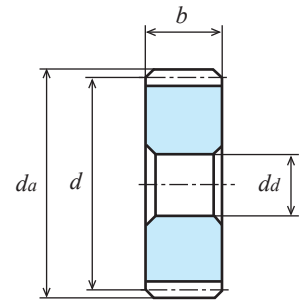
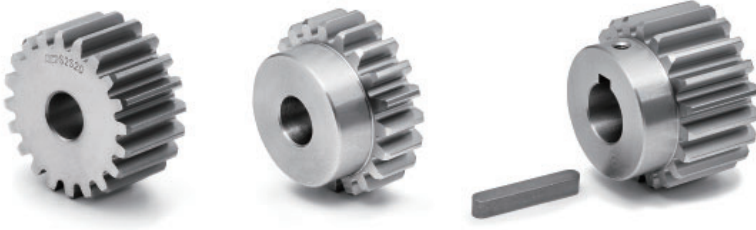

A1 type [-]

Unit: mm

Accuracy Class	Material	Pressure angle	Heat treatment	Tooth surface hardness	Backlash ①
[JIS B 1702-1] N8	S45C	20°	—	—	0.08 to 0.20

★ No surface treatment is applied. Gears with a [#] are provided with key grooves, keys, screw holes, and set screws.

Gears with a [-] are provided with key grooves and keys.

★ This allowable transfer capability table was prepared by using the formulas presented by the JGMA (Japan Gear Manufacturers Association).

For the unit conversion method, refer to P. 20 in "References."

★ KG standard products have different transfer capabilities depending on whether the face width is "Standard" (for light loads) or "Wide" (for heavy loads).

① This is a theoretical value obtained when a pair of gears of the same type and material are meshed with each other.

Catalogue number	Number of teeth <i>z</i>	Refer-ence diameter <i>d</i>	Tip diameter <i>d<sub>a</sub></i>	Type	Face width <i>b</i>	Hole diameter <i>d<sub>d</sub>(H7)</i>	Hub diameter <i>d<sub>h</sub></i>	Hub length <i>l<sub>h</sub></i>	Overall length <i>l</i>	Key groove <i>b<sub>2</sub> × t<sub>2</sub></i>	Screw		Weight <i>W(g)</i>
											<i>M</i>	<i>l<sub>s</sub></i>	
S2S 30A – 1216F	30	φ60	φ64	A1	12	φ16	-	-	12	-	-	-	247.4
S2S 30A – 1414F	30	φ60	φ64	A1	14	φ14	-	-	14	-	-	-	293.8
S2S 30A – 2016F	30	φ60	φ64	A1	20	φ16	-	-	20	-	-	-	412.3
S2S 30A = 2020	30	φ60	φ64	A1	20	φ20	-	-	20	6 × 2.8	-	-	391.9
S2S 30A – 2216F	30	φ60	φ64	A1	22	φ16	-	-	22	-	-	-	453.6
S2S 30B – 1214	30	φ60	φ64	B1	12	φ14	φ52	10	22	-	-	-	338.6
S2S 30B – 1414	30	φ60	φ64	B1	14	φ14	φ40	10	24	-	-	-	380.6
S2S 30B # 1415	30	φ60	φ64	B1	14	φ15	φ40	10	24	5 × 2.3	M4	5	373.3
S2S 30B – 2018N	30	φ60	φ64	B1	20	φ18	φ54	10	30	-	-	-	564.1
S2S 30B – 2216	30	φ60	φ64	B1	22	φ16	φ50	10	32	-	-	-	592.3
S2S 30B # 2220	30	φ60	φ64	B1	22	φ20	φ50	10	32	6 × 2.8	M5	5	558.1
S2S 32A – 1214F	32	φ64	φ68	A1	12	φ14	-	-	12	-	-	-	288.5
S2S 32A – 2016F	32	φ64	φ68	A1	20	φ16	-	-	20	-	-	-	473.5
S2S 32B – 1214	32	φ64	φ68	B1	12	φ14	φ40	10	22	-	-	-	375.3
S2S 32B – 2016	32	φ64	φ68	B1	20	φ16	φ50	10	30	-	-	-	621.2
S2S 32B # 2020	32	φ64	φ68	B1	20	φ20	φ50	10	30	6 × 2.8	M5	5	580.1
S2S 35A – 1216F	35	φ70	φ74	A1	12	φ16	-	-	12	-	-	-	343.6
S2S 35A – 2020F	35	φ70	φ74	A1	20	φ20	-	-	20	-	-	-	554.9
S2S 35B – 1214	35	φ70	φ74	B1	12	φ14	φ60	10	22	-	-	-	558.3
S2S 35B – 2016	35	φ70	φ74	B1	20	φ16	φ60	10	30	-	-	-	779.3
S2S 36A – 1216F	36	φ72	φ76	A1	12	φ16	-	-	12	-	-	-	360.0
S2S 36A – 2016F	36	φ72	φ76	A1	20	φ16	-	-	20	-	-	-	610.0
S2S 36B – 1214	36	φ72	φ76	B1	12	φ14	φ40	10	22	-	-	-	460.0
S2S 36B # 1215	36	φ72	φ76	B1	12	φ15	φ40	10	22	5 × 2.3	M4	5	450.0
S2S 36B # 1220	36	φ72	φ76	B1	12	φ20	φ40	10	22	6 × 2.8	M5	5	420.0
S2S 36B – 2016	36	φ72	φ76	B1	20	φ16	φ50	10	30	-	-	-	750.0
S2S 36B # 2020	36	φ72	φ76	B1	20	φ20	φ50	10	30	6 × 2.8	M5	5	710.0
S2S 38B – 1214	38	φ76	φ80	B1	12	φ14	φ60	10	22	-	-	-	620.0
S2S 40A – 1216F	40	φ80	φ84	A1	12	φ16	-	-	12	-	-	-	0.45(kg)
S2S 40A = 1220	40	φ80	φ84	A1	12	φ20	-	-	12	6 × 2.8	-	-	0.44(kg)
S2S 40A – 2016F	40	φ80	φ84	A1	20	φ16	-	-	20	-	-	-	0.76(kg)
S2S 40A = 2025	40	φ80	φ84	A1	20	φ25	-	-	20	8 × 3.3	-	-	0.71(kg)
S2S 40B – 1214	40	φ80	φ84	B1	12	φ14	φ40	10	22	-	-	-	0.55(kg)
S2S 40B # 1215	40	φ80	φ84	B1	12	φ15	φ40	10	22	5 × 2.3	M4	5	0.54(kg)
S2S 40B # 1218	40	φ80	φ84	B1	12	φ18	φ40	10	22	6 × 2.8	M5	5	0.52(kg)
S2S 40B # 1220	40	φ80	φ84	B1	12	φ20	φ40	10	22	6 × 2.8	M5	5	0.51(kg)
S2S 40BF – 2010	40	φ80	φ84	B1	20	φ10(H8)	φ60	20	40	-	-	-	1.2 (kg)
S2S 40B – 2016	40	φ80	φ84	B1	20	φ16	φ50	10	30	-	-	-	0.90(kg)



2D • 3D CAD

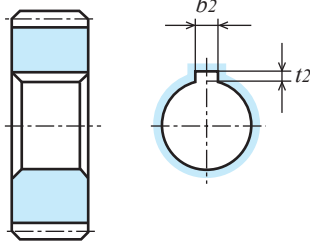

A1 type [=]

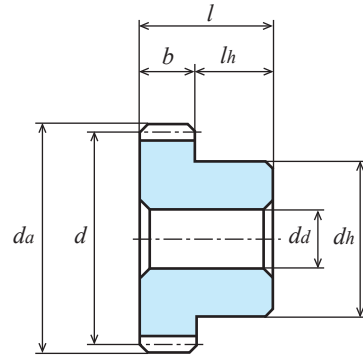

B1 type [-]

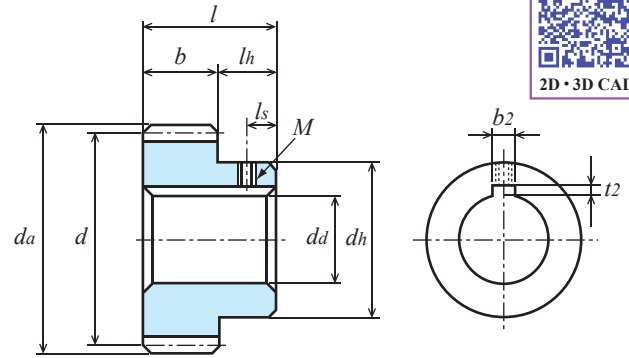

B1 type [#]

Catalogue number	Number of teeth <i>z</i>	Reference diameter <i>d</i>	Tip diameter <i>d<sub>a</sub></i>	Type	Face width <i>b</i>	Hole diameter <i>d<sub>d</sub>(H7)</i>	Hub diameter <i>d<sub>h</sub></i>	Hub length <i>l<sub>h</sub></i>	Overall length <i>l</i>	Key groove <i>b<sub>2</sub> × t<sub>2</sub></i>	Screw		Weight <i>W(g)</i>
											<i>M</i>	<i>l<sub>s</sub></i>	
<b>S2S 42B – 1214</b>	42	φ84	φ 88	B1	12	φ14	φ60	10	22	-	-	-	0.72
<b>S2S 44B – 1214</b>	44	φ88	φ 92	B1	12	φ14	φ60	10	22	-	-	-	0.77
<b>S2S 45A – 1218F</b>	45	φ90	φ 94	A1	12	φ18	-	-	12	-	-	-	0.58
<b>S2S 45A – 2020F</b>	45	φ90	φ 94	A1	20	φ20	-	-	20	-	-	-	0.95
<b>S2S 45B – 1214</b>	45	φ90	φ 94	B1	12	φ14	φ60	10	22	-	-	-	0.80
<b>S2S 45B – 2016</b>	45	φ90	φ 94	B1	20	φ16	φ60	10	30	-	-	-	1.17
<b>S2S 46B – 1214</b>	46	φ92	φ 96	B1	12	φ14	φ60	10	22	-	-	-	0.82
<b>S2S 46B – 2016</b>	46	φ92	φ 96	B1	20	φ16	φ60	10	30	-	-	-	1.22
<b>S2S 48A – 2018F</b>	48	φ96	φ100	A1	20	φ18	-	-	20	-	-	-	1.10
<b>S2S 48B – 1216</b>	48	φ96	φ100	B1	12	φ16	φ40	10	22	-	-	-	0.75
<b>S2S 48B – 2018</b>	48	φ96	φ100	B1	20	φ18	φ50	10	30	-	-	-	1.23

Number of teeth <i>z</i>	Face width <i>b</i>	Allowable transfer capability table for different revolutions per minute, Bending strength, (Unit: kW)							Allowable torque for input revolutions per minute (Unit: N·m)
		10rpm	100rpm	200rpm	400rpm	800rpm	1,200rpm	1,500rpm	100rpm
30	12	0.066	0.66	1.32	2.55	4.32	5.94	7.17	63.02
30	14	0.077	0.77	1.55	2.98	5.04	6.93	8.36	73.53
30	20	0.110	1.100	2.210	4.260	7.200	9.900	11.960	105.05
30	22	0.121	1.21	2.43	4.68	7.92	10.88	13.14	115.55
32	12	0.072	0.72	1.44	2.75	4.61	6.41	7.73	68.75
32	20	0.120	1.20	2.41	4.58	7.69	10.69	12.89	114.59
35	12	0.081	0.81	1.63	3.04	5.04	7.12	8.61	77.35
35	20	0.135	1.35	2.71	5.07	8.40	11.87	14.35	128.92
36	12	0.084	0.84	1.69	3.13	5.19	7.35	8.90	80.21
36	20	0.141	1.41	2.81	5.22	8.64	12.26	14.83	134.65
38	12	0.090	0.90	1.81	3.32	5.53	7.82	9.47	85.94
40	12	0.10	0.97	1.93	3.51	5.87	8.28	10.05	92.63
40	20	0.160	1.610	3.210	5.840	9.760	13.760	16.700	153.75
42	12	0.10	1.03	2.06	3.69	6.20	8.75	10.61	98.36
44	12	0.11	1.09	2.18	3.87	6.53	9.22	11.17	104.09
45	12	0.11	1.12	2.24	3.96	6.70	9.46	11.44	106.95
45	20	0.19	1.87	3.74	6.60	11.16	15.76	19.07	178.57
46	12	0.12	1.15	2.30	4.05	6.86	9.69	11.72	109.82
46	20	0.19	1.92	3.84	6.74	11.44	16.15	19.53	183.35
48	12	0.12	1.21	2.43	4.22	7.19	10.16	12.27	115.55
48	20	0.20	2.02	4.04	7.03	11.98	16.93	20.45	192.90

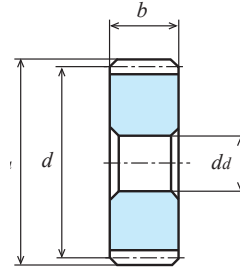

A1 type [-]

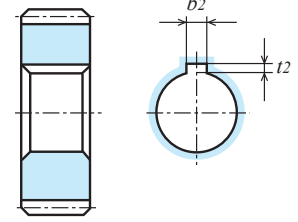

A1 type [=]

Unit: mm

Accuracy Class	Material	Pressure angle	Heat treatment	Tooth surface hardness	Backlash ①
[JIS B 1702-1] N8	S45C	20°	—	—	0.08 to 0.20

★ No surface treatment is applied. Gears with a [#] are provided with key grooves, keys, screw holes, and set screws.

Gears with a [=] are provided with key grooves and keys.

★ This allowable transfer capability table was prepared by using the formulas presented by the JGMA (Japan Gear Manufacturers Association).

For the unit conversion method, refer to P. 20 in "References."

★ KG standard products have different transfer capabilities depending on whether the face width is "Standard" (for light loads) or "Wide" (for heavy loads).

① This is a theoretical value obtained when a pair of gears of the same type and material are meshed with each other.

Catalogue number	Number of teeth <i>z</i>	Reference diameter <i>d</i>	Tip diameter <i>d<sub>a</sub></i>	Type	Face width <i>b</i>	Hole diameter <i>d<sub>i</sub></i> (H7)	Hub diameter <i>d<sub>h</sub></i>	Hub length <i>l<sub>h</sub></i>	Overall length <i>l</i>	Key groove <i>b<sub>2</sub> × t<sub>2</sub></i>	Screw		Dimension of Rim <i>d<sub>i</sub></i>	Thick-ness of Web <i>b<sub>w</sub></i>	Weight <i>W</i> (kg)
											<i>M</i>	<i>l<sub>s</sub></i>			
S2S 50A – 1218F	50	φ100	φ104	A1	12	φ18	-	-	12	-	-	-	-	-	0.72
S2S 50A = 1220	50	φ100	φ104	A1	12	φ20	-	-	12	6 × 2.8	-	-	-	-	0.71
S2S 50A – 2018F	50	φ100	φ104	A1	20	φ18	-	-	20	-	-	-	-	-	1.19
S2S 50B – 1216	50	φ100	φ104	B1	12	φ16	φ50	10	22	-	-	-	-	-	0.86
S2S 50B # 1220	50	φ100	φ104	B1	12	φ20	φ50	10	22	6 × 2.8	M5	5	-	-	0.84
S2S 50BF – 2012	50	φ100	φ104	B1	20	φ12(H8)	φ70	20	40	-	-	-	-	-	1.8
S2S 50B – 2018	50	φ100	φ104	B1	20	φ18	φ60	10	30	-	-	-	-	-	1.40
S2S 50B # 2020	50	φ100	φ104	B1	20	φ20	φ60	10	30	6 × 2.8	M5	5	-	-	1.38
S2S 50B # 2025	50	φ100	φ104	B1	20	φ25	φ60	10	30	8 × 3.3	M6	5	-	-	1.33
S2S 52B – 2018	52	φ104	φ108	B1	20	φ18	φ60	10	30	-	-	-	-	-	1.50
S2S 55B – 2018	55	φ110	φ114	B1	20	φ18	φ60	10	30	-	-	-	-	-	1.66
S2S 56A – 1218F	56	φ112	φ116	A1	12	φ18	-	-	12	-	-	-	-	-	0.90
S2S 56A – 2020F	56	φ112	φ116	A1	20	φ20	-	-	20	-	-	-	-	-	1.50
S2S 56B – 1216	56	φ112	φ116	B1	12	φ16	φ50	10	22	-	-	-	-	-	1.05
S2S 56B – 2018	56	φ112	φ116	B1	20	φ18	φ60	10	30	-	-	-	-	-	1.71
S2S 60A – 1220F	60	φ120	φ124	A1	12	φ20	-	-	12	-	-	-	-	-	1.04
S2S 60A – 2018F	60	φ120	φ124	A1	20	φ18	-	-	20	-	-	-	-	-	1.74
S2S 60B – 1216	60	φ120	φ124	B1	12	φ16	φ50	10	22	-	-	-	-	-	1.19
S2S 60B # 1220	60	φ120	φ124	B3	12	φ20	φ50	10	22	6 × 2.8	M5	5	φ102	6	1.16
S2S 60BF – 2012	60	φ120	φ124	B1	20	φ12(H8)	φ85	20	40	-	-	-	-	-	2.62
S2S 60B – 2018	60	φ120	φ124	B1	20	φ18	φ60	10	30	-	-	-	-	-	1.94
S2S 64A – 1220F	64	φ128	φ132	A1	12	φ20	-	-	12	-	-	-	-	-	1.18
S2S 64B – 1216	64	φ128	φ132	B1	12	φ16	φ50	10	22	-	-	-	-	-	1.33
S2S 64B – 2018	64	φ128	φ132	B1	20	φ18	φ60	10	30	-	-	-	-	-	2.18
S2S 65A – 1218F	65	φ130	φ134	A1	12	φ18	-	-	12	-	-	-	-	-	1.23
S2S 70A – 1220F	70	φ140	φ144	A1	12	φ20	-	-	12	-	-	-	-	-	1.42
S2S 70A – 2018F	70	φ140	φ144	A1	20	φ18	-	-	20	-	-	-	-	-	2.38
S2S 70B – 2018	70	φ140	φ144	B1	20	φ18	φ70	10	30	-	-	-	-	-	2.66
S2S 72A – 1220F	72	φ144	φ148	A1	12	φ20	-	-	12	-	-	-	-	-	1.51
S2S 72B – 2020	72	φ144	φ148	B1	20	φ20	φ60	10	30	-	-	-	-	-	2.71
S2S 75A – 1218F	75	φ150	φ154	A1	12	φ18	-	-	12	-	-	-	-	-	1.64
S2S 75A – 2020F	75	φ150	φ154	A1	20	φ20	-	-	20	-	-	-	-	-	2.73
S2S 75B – 2020	75	φ150	φ154	B1	20	φ20	φ70	10	30	-	-	-	-	-	3.00
S2S 80A – 1220F	80	φ160	φ164	A1	12	φ20	-	-	12	-	-	-	-	-	1.86
S2S 80A – 2018F	80	φ160	φ164	A1	20	φ18	-	-	20	-	-	-	-	-	3.12

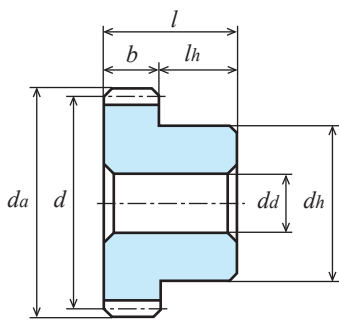

B1 type [-]

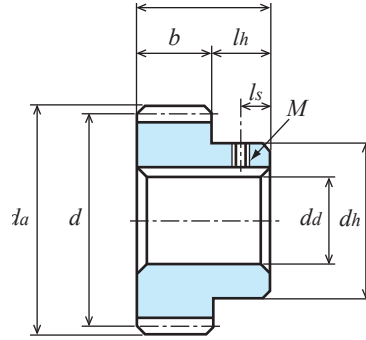

B1 type [#]

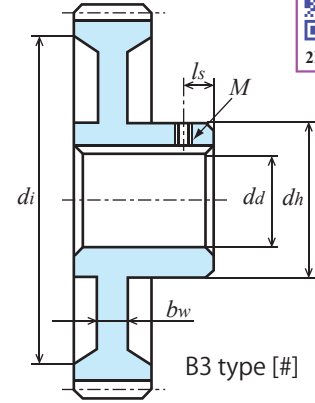
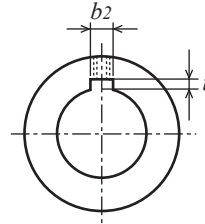

B3 type [#]

Catalogue number	Number of teeth <i>z</i>	Reference diameter <i>d</i>	Tip diameter <i>da</i>	Type	Face width <i>b</i>	Hole diameter <i>da(H7)</i>	Hub diameter <i>dh</i>	Hub length <i>lh</i>	Overall length <i>l</i>	Key groove <i>b<sub>2</sub> × t<sub>2</sub></i>	Screw		Dimension of Rim <i>di</i>	Thick-ness of Web <i>b<sub>w</sub></i>	Weight <i>W(kg)</i>
											<i>M</i>	<i>ls</i>			
S2S 80B – 1218	80	φ160	φ164	B1	12	φ18	φ 50	10	22	-	-	-	-	-	2.01
S2S 80BF – 2015	80	φ160	φ164	B1	20	φ15	φ115	20	40	-	-	-	-	-	4.72
S2S 80B – 2020	80	φ160	φ164	B1	20	φ20	φ 60	10	30	-	-	-	-	-	3.31
S2S 85A – 2020F	85	φ170	φ174	A1	20	φ20	-	-	20	-	-	-	-	-	3.51
S2S 85B – 2020	85	φ170	φ174	B1	20	φ20	φ 70	10	30	-	-	-	-	-	3.79
S2S 90A – 1218F	90	φ180	φ184	A1	12	φ18	-	-	12	-	-	-	-	-	2.37
S2S 90A – 2020F	90	φ180	φ184	A1	20	φ20	-	-	20	-	-	-	-	-	3.95
S2S 90B – 1218	90	φ180	φ184	B1	12	φ18	φ 60	10	22	-	-	-	-	-	2.58
S2S 90B – 2020	90	φ180	φ184	B1	20	φ20	φ 80	10	30	-	-	-	-	-	4.32
S2S 100A – 1220F	100	φ200	φ204	A1	12	φ20	-	-	12	-	-	-	-	-	2.93
S2S 100A – 2018F	100	φ200	φ204	A1	20	φ18	-	-	20	-	-	-	-	-	4.89
S2S 100B – 1218	100	φ200	φ204	B1	12	φ18	φ 50	10	22	-	-	-	-	-	3.07
S2S 100B # 1220	100	φ200	φ204	B3	12	φ20	φ 50	10	22	6 × 2.8	M5	5	φ182	6	1.95
S2S 100B – 2020	100	φ200	φ204	B1	20	φ20	φ 60	10	30	-	-	-	-	-	5.08

Number of teeth <i>z</i>	Face width <i>b</i>	Allowable transfer capability table for different revolutions per minute, Bending strength, (Unit: kW)						
		10rpm	100rpm	200rpm	400rpm	800rpm	1,200rpm	1,500rpm
50	12	0.13	1.28	2.54	4.39	7.52	10.62	12.81
50	20	0.210	2.120	4.210	7.280	12.470	17.630	21.270
52	20	0.22	2.23	4.41	7.59	13.06	18.47	22.34
55	20	0.24	2.39	4.68	8.00	13.86	19.61	23.91
56	12	0.15	1.47	2.86	4.88	8.47	11.99	14.67
56	20	0.24	2.44	4.76	8.13	14.12	19.98	24.44
60	12	0.16	1.59	3.07	5.19	9.10	12.88	15.94
60	20	0.260	2.640	5.090	8.610	15.080	21.350	26.410
64	12	0.17	1.72	3.27	5.50	9.75	13.77	-
64	20	0.29	2.87	5.46	9.16	16.25	22.95	-
65	12	0.18	1.75	3.33	5.57	9.91	14.02	-
70	12	0.19	1.91	3.58	5.93	10.71	15.31	-
70	20	0.320	3.170	5.920	9.820	17.740	25.350	-
72	12	0.20	1.98	3.67	6.08	11.03	15.82	-
72	20	0.33	3.30	6.12	10.13	18.38	26.37	-
75	12	0.21	2.07	3.82	6.35	11.50	16.59	-
75	20	0.35	3.46	6.37	10.58	19.14	27.65	-
80	12	0.22	2.24	4.06	6.79	12.28	-	-
80	20	0.370	3.700	6.720	11.230	20.310	-	-
85	20	0.40	3.99	7.14	12.02	21.71	-	-
90	12	0.26	2.56	4.51	7.64	13.77	-	-
90	20	0.420	4.230	7.460	12.630	22.780	-	-
100	12	0.29	2.86	4.95	8.48	15.36	-	-
100	20	0.480	4.730	8.180	14.010	25.390	-	-

Allowable torque for input revolutions per minute (Unit: N·m)
100rpm
122.23
202.45
212.95
228.23
140.38
233.01
151.84
252.11
164.25
274.07
167.12
182.39
302.73
189.08
315.14
197.67
330.42
213.91
353.34
381.03
244.47
403.95
273.12
451.70



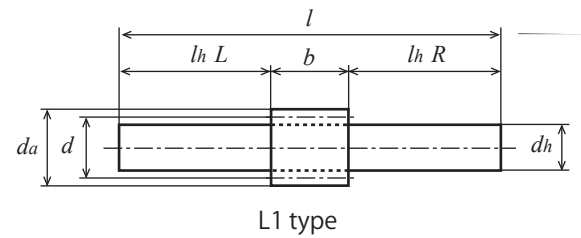
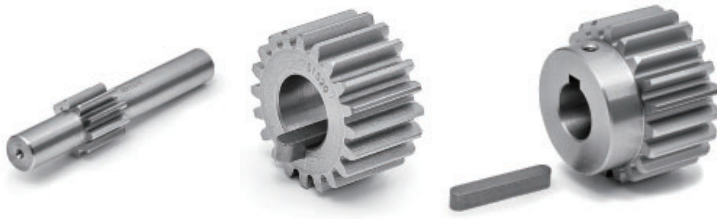

Accuracy Class	Material	Pressure angle	Heat treatment	Tooth surface hardness	Backlash ①
[JIS B 1702-1] N8	S45C	20°	—	—	0.1 to 0.25

★ No surface treatment is applied. Gears with a [#] are provided with key grooves, keys, screw holes, and set screws. Gears with a [=] are provided with key grooves and keys.

★ This allowable transfer capability table was prepared by using the formulas presented by the JGMA (Japan Gear Manufacturers Association). For the unit conversion method, refer to P. 20 in "References."

★ KG standard products have different transfer capabilities depending on whether the face width is "Standard" (for light loads) or "Wide" (for heavy loads).

★ [Profile-shifted] is a profile-shifted gear with a rack shift coefficient  $x$  of 0.5.

① This is a theoretical value obtained when a pair of gears of the same type and material are meshed with each other.

Catalogue number	Number of teeth $z$	Refer-ence diameter $d$	Tip diameter $d_a$	Type	Face width $b$	Hole diameter $d_d(H7)$	Hub diameter $d_h$	Hub length $l_h$	Overall length $l$	Key groove $b_2 \times t_2$	Screw		Weight $W(g)$
											$M$	$l_s$	
<b>S2.5S 10L — 2820</b>	10	[Profile-shifted]	$\phi 31.66$	L1	28	-	$\phi 20(h9)$	L40 R80	148	-	-	-	403.8
<b>S2.5S 12K — 2812</b>	12	$\phi 30$	$\phi 35$	K2	28	$\phi 12(H8)$	$\phi 35$	32	60	-	-	-	343.8
<b>S2.5S 14B — 1612N</b>	14	$\phi 35$	$\phi 40$	B1	16	$\phi 12$	$\phi 27$	12	28	-	-	-	150.0
<b>S2.5S 14B — 1812N</b>	14	$\phi 35$	$\phi 40$	B1	18	$\phi 12$	$\phi 28$	12	30	-	-	-	167.4
<b>S2.5S 16A — 1612</b>	16	$\phi 40$	$\phi 45$	A1	16	$\phi 12$	-	-	16	-	-	-	143.6
<b>S2.5S 16A — 2812</b>	16	$\phi 40$	$\phi 45$	A1	28	$\phi 12$	-	-	28	-	-	-	251.4
<b>S2.5S 16B — 1812N</b>	16	$\phi 40$	$\phi 45$	B1	18	$\phi 12$	$\phi 32$	12	30	-	-	-	226.8
<b>S2.5S 18A — 1612</b>	18	$\phi 45$	$\phi 50$	A1	16	$\phi 12$	-	-	16	-	-	-	185.6
<b>S2.5S 18B — 1612N</b>	18	$\phi 45$	$\phi 50$	B1	16	$\phi 12$	$\phi 36$	12	28	-	-	-	271.0
<b>S2.5S 18B — 1814N</b>	18	$\phi 45$	$\phi 50$	B1	18	$\phi 14$	$\phi 36$	12	30	-	-	-	284.5
<b>S2.5S 20A — 1612F</b>	20	$\phi 50$	$\phi 55$	A1	16	$\phi 12$	-	-	16	-	-	-	232.4
<b>S2.5S 20A — 1812F</b>	20	$\phi 50$	$\phi 55$	A1	18	$\phi 12$	-	-	18	-	-	-	261.5
<b>S2.5S 20A — 2514F</b>	20	$\phi 50$	$\phi 55$	A1	25	$\phi 14$	-	-	25	-	-	-	355.1
<b>S2.5S 20A — 2814F</b>	20	$\phi 50$	$\phi 55$	A1	28	$\phi 14$	-	-	28	-	-	-	397.7
<b>S2.5S 20A = 2825</b>	20	$\phi 50$	$\phi 55$	A1	28	$\phi 25$	-	-	28	8 × 3.3	-	-	317.9
<b>S2.5S 20B — 1812</b>	20	$\phi 50$	$\phi 55$	B1	18	$\phi 12$	$\phi 40$	12	30	-	-	-	369.4
<b>S2.5S 20B # 1820</b>	20	$\phi 50$	$\phi 55$	B1	18	$\phi 20$	$\phi 40$	12	30	6 × 2.8	M5	6	317.2
<b>S2.5S 20B — 2814</b>	20	$\phi 50$	$\phi 55$	B1	28	$\phi 14$	$\phi 42$	12	40	-	-	-	514.1
<b>S2.5S 20B # 2825</b>	20	$\phi 50$	$\phi 55$	B1	28	$\phi 25$	$\phi 42$	12	40	8 × 3.3	M5	6	399.3
<b>S2.5S 24A — 1814F</b>	24	$\phi 60$	$\phi 65$	A1	18	$\phi 14$	-	-	18	-	-	-	377.8
<b>S2.5S 24A = 1820</b>	24	$\phi 60$	$\phi 65$	A1	18	$\phi 20$	-	-	18	6 × 2.8	-	-	352.8
<b>S2.5S 24A — 2814F</b>	24	$\phi 60$	$\phi 65$	A1	28	$\phi 14$	-	-	28	-	-	-	587.6
<b>S2.5S 24B — 1614</b>	24	$\phi 60$	$\phi 65$	B1	16	$\phi 14$	$\phi 50$	12	28	-	-	-	506.6
<b>S2.5S 24B — 1814</b>	24	$\phi 60$	$\phi 65$	B1	18	$\phi 14$	$\phi 40$	12	30	-	-	-	482.0
<b>S2.5S 24B — 2515</b>	24	$\phi 60$	$\phi 65$	B1	25	$\phi 15$	$\phi 50$	12	37	-	-	-	689.0
<b>S2.5S 25A = 1820</b>	25	$\phi 62.5$	$\phi 67.5$	A1	18	$\phi 20$	-	-	18	6 × 2.8	-	-	386.7
<b>S2.5S 28A — 1614F</b>	28	$\phi 70$	$\phi 75$	A1	16	$\phi 14$	-	-	16	-	-	-	460.0
<b>S2.5S 28A — 1814F</b>	28	$\phi 70$	$\phi 75$	A1	18	$\phi 14$	-	-	18	-	-	-	520.0
<b>S2.5S 28B — 1814</b>	28	$\phi 70$	$\phi 75$	B1	18	$\phi 14$	$\phi 40$	12	30	-	-	-	630.0
<b>S2.5S 28B # 1820</b>	28	$\phi 70$	$\phi 75$	B1	18	$\phi 20$	$\phi 40$	12	30	6 × 2.8	M5	6	580.0
<b>S2.5S 30A — 2518F</b>	30	$\phi 75$	$\phi 80$	A1	25	$\phi 18$	-	-	25	-	-	-	0.82(kg)
<b>S2.5S 30B — 1814</b>	30	$\phi 75$	$\phi 80$	B1	18	$\phi 14$	$\phi 40$	12	30	-	-	-	0.71(kg)
<b>S2.5S 30B — 2816</b>	30	$\phi 75$	$\phi 80$	B1	28	$\phi 16$	$\phi 50$	12	40	-	-	-	1.09(kg)



2D • 3D CAD

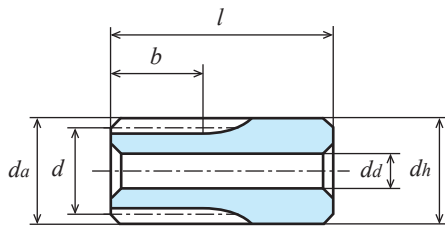

K2 type [-]

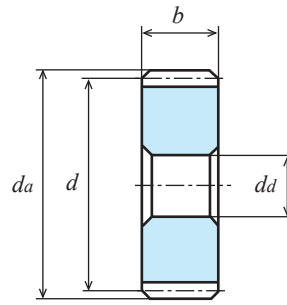

A1 type [-]

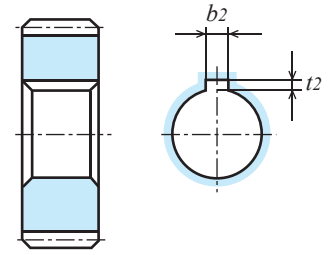

A1 type [=]

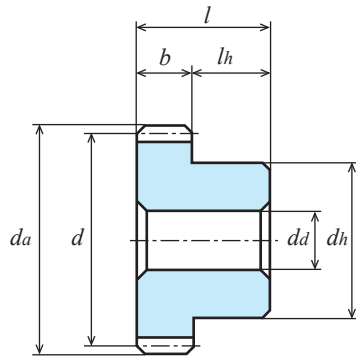

B1 type [-]

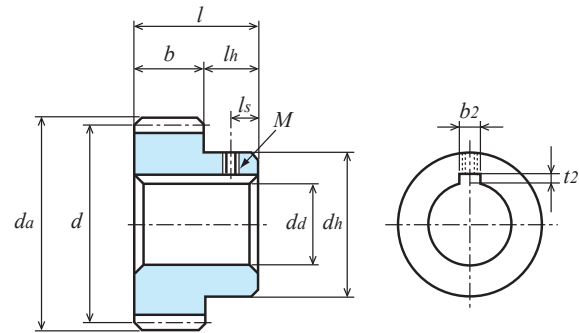

B1 type [#]

Number of teeth <i>z</i>	Face width <i>b</i>	Allowable transfer capability table for different revolutions per minute, Bending strength, (Unit: kW)							Allowable torque for input revolutions per minute (Unit: N·m)
		10rpm	100rpm	200rpm	400rpm	800rpm	1,200rpm	1,500rpm	100rpm
10	28	0.064	0.64	1.29	2.58	5.07	7.02	8.29	61.11
12	28	0.059	0.59	1.18	2.37	4.57	6.29	7.40	56.34
14	16	0.044	0.44	0.88	1.77	3.30	4.50	5.25	42.01
14	18	0.049	0.49	0.99	1.99	3.72	5.06	5.91	46.79
16	16	0.055	0.55	1.10	2.20	3.99	5.38	6.31	52.52
16	18	0.061	0.61	1.23	2.47	4.49	6.05	7.10	58.25
16	28	0.096	0.96	1.93	3.85	7.00	9.42	11.06	91.67
18	16	0.066	0.66	1.32	2.64	4.67	6.23	7.48	63.02
18	18	0.074	0.74	1.48	2.97	5.25	7.01	8.41	70.66
20	16	0.077	0.78	1.55	3.09	5.34	7.13	8.66	74.48
20	18	0.087	0.87	1.75	3.47	6.01	8.03	9.74	83.08
20	25	0.122	1.220	2.450	4.860	8.400	11.230	13.620	116.51
20	28	0.136	1.36	2.72	5.40	9.34	12.48	15.15	129.87
24	16	0.101	1.01	2.03	3.90	6.60	9.08	10.97	96.45
24	18	0.114	1.14	2.28	4.39	7.43	10.22	12.34	108.86
24	25	0.158	1.58	3.17	6.10	10.32	14.19	17.13	150.88
24	28	0.177	1.77	3.55	6.83	11.56	15.89	19.19	169.02
25	18	0.121	1.21	2.41	4.62	7.77	10.76	12.98	115.55
28	16	0.13	1.26	2.51	4.70	7.79	11.01	13.30	120.32
28	18	0.14	1.41	2.83	5.28	8.77	12.38	14.97	134.65
30	18	0.16	1.55	3.10	5.72	9.50	13.44	16.28	148.02
30	25	0.220	2.160	4.320	7.950	13.210	18.690	22.640	206.27
30	28	0.24	2.41	4.82	8.89	14.77	20.91	25.33	230.14

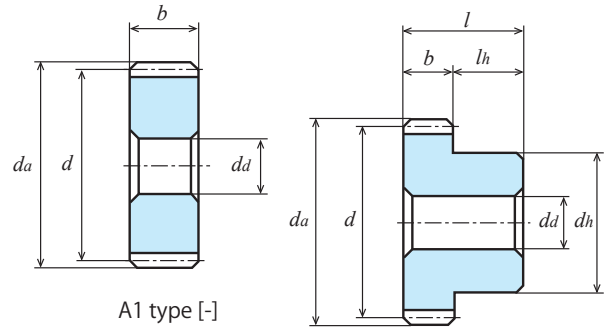
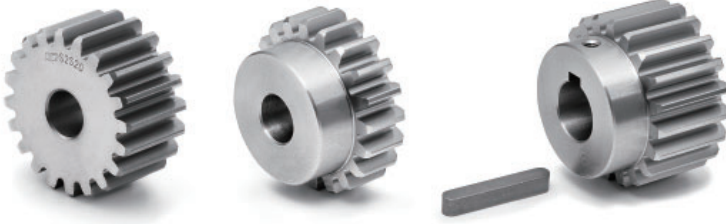

Unit: mm

Accuracy Class	Material	Pressure angle	Heat treatment	Tooth surface hardness	Backlash ①
[JIS B 1702-1] N8	S45C	20°	—	—	0.1 ~ 0.25

★ No surface treatment is applied. Gears with a [#] are provided with key grooves, keys, screw holes, and set screws.

★ This allowable transfer capability table was prepared by using the formulas presented by the JGMA (Japan Gear Manufacturers Association). For the unit conversion method, refer to P. 20 in "References."

★ KG standard products have different transfer capabilities depending on whether the face width is "Standard" (for light loads) or "Wide" (for heavy loads).

① This is a theoretical value obtained when a pair of gears of the same type and material are meshed with each other.

Catalogue number	Number of teeth <i>z</i>	Reference diameter <i>d</i>	Tip diameter <i>da</i>	Type	Face width <i>b</i>	Hole diameter <i>da</i> (H7)	Hub diameter <i>dh</i>	Hub length <i>lh</i>	Overall length <i>l</i>	Key groove <i>b</i> <sub>2</sub> × <i>t</i> <sub>2</sub>	Screw		Dimension of Rim <i>d</i> <sub>i</sub>	Thick-ness of Web <i>b</i> <sub>w</sub>	Weight <i>W</i> (kg)
											<i>M</i>	<i>l</i> <sub>s</sub>			
S2.5S 32A – 1616F	32	φ 80	φ 85	A1	16	φ16	-	-	16	-	-	-	-	-	0.61
S2.5S 32A – 2518F	32	φ 80	φ 85	A1	25	φ18	-	-	25	-	-	-	-	-	0.94
S2.5S 32B – 1616	32	φ 80	φ 85	B1	16	φ16	φ 50	12	28	-	-	-	-	-	0.77
S2.5S 32B – 2516	32	φ 80	φ 85	B1	25	φ16	φ 60	12	37	-	-	-	-	-	1.20
S2.5S 36A – 1616F	36	φ 90	φ 95	A1	16	φ16	-	-	16	-	-	-	-	-	0.77
S2.5S 36A – 2518F	36	φ 90	φ 95	A1	25	φ18	-	-	25	-	-	-	-	-	1.20
S2.5S 36B – 1616	36	φ 90	φ 95	B1	16	φ16	φ 50	12	28	-	-	-	-	-	0.94
S2.5S 36B – 2518	36	φ 90	φ 95	B1	25	φ18	φ 60	12	37	-	-	-	-	-	1.44
S2.5S 40A – 1616F	40	φ100	φ105	A1	16	φ16	-	-	16	-	-	-	-	-	0.96
S2.5S 40A – 2518F	40	φ100	φ105	A1	25	φ18	-	-	25	-	-	-	-	-	1.49
S2.5S 40B – 1616	40	φ100	φ105	B1	16	φ16	φ 50	12	28	-	-	-	-	-	1.13
S2.5S 40B # 1620	40	φ100	φ105	B1	16	φ20	φ 50	12	28	6 × 2.8	M5	6	-	-	1.10
S2.5S 40B # 1625	40	φ100	φ105	B1	16	φ25	φ 50	12	28	8 × 3.3	M6	6	-	-	1.06
S2.5S 40BF – 2512	40	φ100	φ105	B1	25	φ12(H8)	φ 70	20	45	-	-	-	-	-	2.1
S2.5S 40B – 2518	40	φ100	φ105	B1	25	φ18	φ 60	12	37	-	-	-	-	-	1.73
S2.5S 40B # 2525	40	φ100	φ105	B1	25	φ25	φ 60	12	37	8 × 3.3	M6	6	-	-	1.66
S2.5S 48A – 1616F	48	φ120	φ125	A1	16	φ16	-	-	16	-	-	-	-	-	1.40
S2.5S 48A – 2518F	48	φ120	φ125	A1	25	φ18	-	-	25	-	-	-	-	-	2.17
S2.5S 48B – 1616	48	φ120	φ125	B1	16	φ16	φ 50	12	28	-	-	-	-	-	1.56
S2.5S 48B – 2518	48	φ120	φ125	B1	25	φ18	φ 60	12	37	-	-	-	-	-	2.41
S2.5S 50A – 1616F	50	φ125	φ130	A1	16	φ16	-	-	16	-	-	-	-	-	1.52
S2.5S 50A – 2518F	50	φ125	φ130	A1	25	φ18	-	-	25	-	-	-	-	-	2.36
S2.5S 50B – 2518	50	φ125	φ130	B1	25	φ18	φ 60	12	37	-	-	-	-	-	2.60
S2.5S 56A – 2518F	56	φ140	φ145	A1	25	φ18	-	-	25	-	-	-	-	-	2.97
S2.5S 56B – 1618	56	φ140	φ145	B1	16	φ18	φ 60	12	28	-	-	-	-	-	2.15
S2.5S 60A – 1616F	60	φ150	φ155	A1	16	φ16	-	-	16	-	-	-	-	-	2.19
S2.5S 60A – 2518F	60	φ150	φ155	A1	25	φ18	-	-	25	-	-	-	-	-	3.42
S2.5S 60B – 1618	60	φ150	φ155	B1	16	φ18	φ 60	12	28	-	-	-	-	-	2.43
S2.5S 60B – 2520	60	φ150	φ155	B1	25	φ20	φ 70	12	37	-	-	-	-	-	3.74
S2.5S 64A – 1616F	64	φ160	φ165	A1	16	φ16	-	-	16	-	-	-	-	-	2.50
S2.5S 64A – 2518F	64	φ160	φ165	A1	25	φ18	-	-	25	-	-	-	-	-	3.90
S2.5S 70BF – 2520	70	φ175	φ180	B1	25	φ20	φ125	20	45	-	-	-	-	-	6.52
S2.5S 72A – 1616F	72	φ180	φ185	A1	16	φ16	-	-	16	-	-	-	-	-	3.17
S2.5S 72A – 2518F	72	φ180	φ185	A1	25	φ18	-	-	25	-	-	-	-	-	4.94



2D • 3D CAD

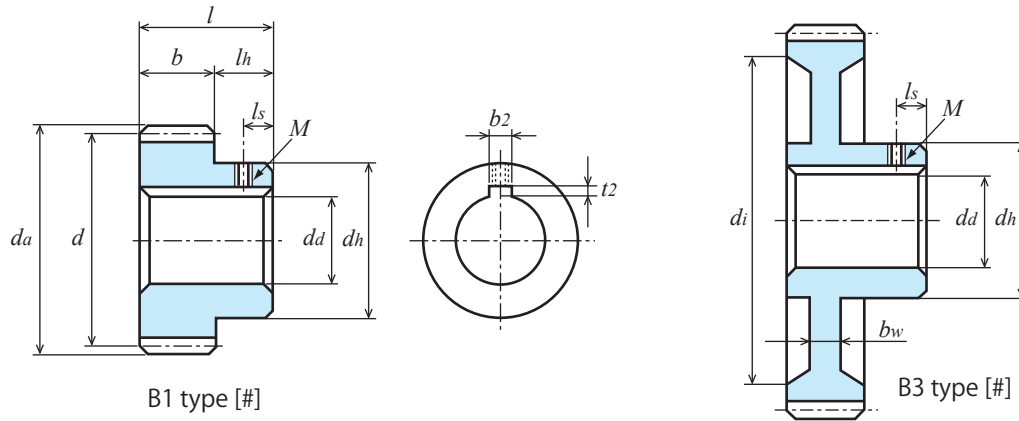

Catalogue number	Number of teeth <i>z</i>	Reference diameter <i>d</i>	Tip diameter <i>da</i>	Type	Face width <i>b</i>	Hole diameter <i>da(H7)</i>	Hub diameter <i>dh</i>	Hub length <i>lh</i>	Overall length <i>l</i>	Key groove <i>b<sub>2</sub> × t<sub>2</sub></i>	Screw		Dimension of Rim <i>di</i>	Thick-ness of Web <i>b<sub>w</sub></i>	Weight <i>W(kg)</i>
											<i>M</i>	<i>ls</i>			
<b>S2.5S 80A – 1618F</b>	80	φ200	φ205	A1	16	φ18	-	-	16	-	-	-	-	-	3.91
<b>S2.5S 80A – 2520F</b>	80	φ200	φ205	A1	25	φ20	-	-	25	-	-	-	-	-	6.10
<b>S2.5S 80B – 2522</b>	80	φ200	φ205	B1	25	φ22	φ 70	12	37	-	-	-	-	-	6.42
<b>S2.5S 80B # 2535</b>	80	φ200	φ205	B3	25	φ35	φ 70	12	37	10 × 3.3	M8	6	φ177	13	4.37

Number of teeth <i>z</i>	Face width <i>b</i>	Allowable transfer capability table for different revolutions per minute, Bending strength, (Unit: kW)							Allowable torque for input revolutions per minute (Unit: N·m)	
		10rpm	100rpm	200rpm	400rpm	800rpm	1,200rpm	1,500rpm	100rpm	
32	16	0.15	1.50	3.01	5.46	9.13	12.89	15.64	143.24	
32	25	0.24	2.35	4.70	8.54	14.27	20.14	24.44	224.41	
36	16	0.18	1.76	3.51	6.20	10.50	14.83	17.94	168.07	
36	25	0.27	2.75	5.49	9.69	16.41	23.17	28.03	262.61	
40	16	0.20	2.01	4.00	6.92	11.85	16.74	20.19	191.94	
40	25	0.310	3.140	6.230	10.780	18.470	26.100	31.480	299.86	
48	16	0.25	2.53	4.87	8.25	14.45	20.45	25.30	341.60	
48	25	0.40	3.95	7.61	12.89	22.58	31.95	39.53	377.21	
50	16	0.27	2.66	5.09	8.56	15.12	21.36	26.61	254.02	
50	25	0.410	4.140	7.910	13.330	23.530	33.230	41.400	395.36	
56	16	0.31	3.06	5.71	9.47	17.11	24.44	-	292.22	
56	25	0.48	4.77	8.92	14.80	26.73	38.19	-	455.52	
60	16	0.33	3.32	6.12	10.16	18.41	26.56	-	317.05	
60	25	0.52	5.19	9.56	15.87	28.76	41.50	-	495.63	
64	16	0.36	3.59	6.51	10.89	19.69	-	-	342.83	
64	25	0.56	5.60	10.17	17.01	30.77	-	-	534.78	
70	25	0.620	6.190	11.000	18.560	33.500	-	-	591.13	
72	16	0.41	4.12	7.27	12.31	22.20	-	-	393.44	
72	25	0.64	6.44	11.37	19.24	34.69	-	-	615.00	
80	16	0.47	4.62	8.00	13.70	24.84	-	-	441.19	
80	25	0.720	7.170	12.410	21.260	38.530	-	-	684.71	

- CONTENTS
- INFORMATION
- GEARBOXES
- ANTI-BACKLASH SPUR GEARS
- SPUR GEARS**
- RACKS
- HELICAL GEARS AND SCREW GEARS
- MITER GEARS
- BEVEL GEARS
- WORMS AND WORM WHEELS
- REFERENCES

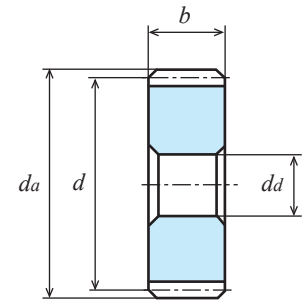
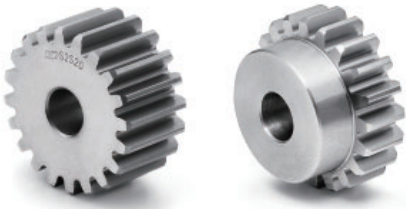

A1 type [-]

Unit: mm

Accuracy Class	Material	Pressure angle	Heat treatment	Tooth surface hardness	Backlash ①
[JIS B 1702-1] N8	S45C	20°	—	—	0.12 to 0.3

★ No surface treatment is applied.

★ This allowable transfer capability table was prepared by using the formulas presented by the JGMA (Japan Gear Manufacturers Association). For the unit conversion method, refer to P. 20 in "References."

★ KG standard products have different transfer capabilities depending on whether the face width is "Standard" (for light loads) or "Wide" (for heavy loads).

① This is a theoretical value obtained when a pair of gears of the same type and material are meshed with each other.

Catalogue number	Number of teeth	Reference diameter	Tip diameter	Type	Face width	Hole diameter	Hub diameter	Hub length	Overall length	Weight
	$z$	$d$	$d_a$							
S3S 14A – 3516	14	φ42	φ 48	A1	35	φ16	-	-	35	0.33
S3S 15A – 3016	15	φ45	φ 51	A1	30	φ16	-	-	30	0.33
S3S 16B – 2216N	16	φ48	φ 54	B1	22	φ16	φ40	13	35	0.39
S3S 16B – 3016N	16	φ48	φ 54	B1	30	φ16	φ40	13	43	0.49
S3S 18A – 2216	18	φ54	φ 60	A1	22	φ16	-	-	22	0.36
S3S 18A – 3016	18	φ54	φ 60	A1	30	φ16	-	-	30	0.49
S3S 18B – 3018N	18	φ54	φ 60	B1	30	φ18	φ46	13	43	0.62
S3S 20A – 2216F	20	φ60	φ 66	A1	22	φ16	-	-	22	0.45
S3S 20A – 3018F	20	φ60	φ 66	A1	30	φ18	-	-	30	0.61
S3S 20B – 2218	20	φ60	φ 66	B1	22	φ18	φ40	13	35	0.55
S3S 20B – 3018N	20	φ60	φ 66	B1	30	φ18	φ52	13	43	0.80
S3S 24A – 2216F	24	φ72	φ 78	A1	22	φ16	-	-	22	0.67
S3S 24A – 3018F	24	φ72	φ 78	A1	30	φ18	-	-	30	0.90
S3S 24A – 3518F	24	φ72	φ 78	A1	35	φ18	-	-	35	1.05
S3S 24B – 3020N	24	φ72	φ 78	B1	30	φ20	φ60	13	43	1.14
S3S 25A – 2218F	25	φ75	φ 81	A1	22	φ18	-	-	22	0.72
S3S 25A – 3018F	25	φ75	φ 81	A1	30	φ18	-	-	30	0.98
S3S 25A – 3520F	25	φ75	φ 81	A1	35	φ20	-	-	35	1.13
S3S 25B – 2220	25	φ75	φ 81	B1	22	φ20	φ50	13	35	0.88
S3S 25B – 3020N	25	φ75	φ 81	B1	30	φ20	φ60	13	43	1.22
S3S 28A – 2218F	28	φ84	φ 90	A1	22	φ18	-	-	22	0.91
S3S 28A – 3020F	28	φ84	φ 90	A1	30	φ20	-	-	30	1.23
S3S 28B – 2220	28	φ84	φ 90	B1	22	φ20	φ50	13	35	1.07
S3S 28B – 3022N	28	φ84	φ 90	B1	30	φ22	φ60	13	43	1.47
S3S 30A – 2220F	30	φ90	φ 96	A1	22	φ20	-	-	22	1.04
S3S 30A – 3022F	30	φ90	φ 96	A1	30	φ22	-	-	30	1.41
S3S 30B – 2218	30	φ90	φ 96	B1	22	φ18	φ50	13	35	1.23
S3S 30B – 3022N	30	φ90	φ 96	B1	30	φ22	φ60	13	43	1.66
S3S 32A – 2020F	32	φ96	φ102	A1	20	φ20	-	-	20	1.09
S3S 32A – 3022F	32	φ96	φ102	A1	30	φ22	-	-	30	1.62
S3S 32B – 2018	32	φ96	φ102	B1	20	φ18	φ50	13	33	1.27
S3S 32B – 3025N	32	φ96	φ102	B1	30	φ25	φ65	13	43	1.88
S3S 32B – 3220	32	φ96	φ102	B1	32	φ20	φ60	13	45	2.00



2D • 3D CAD

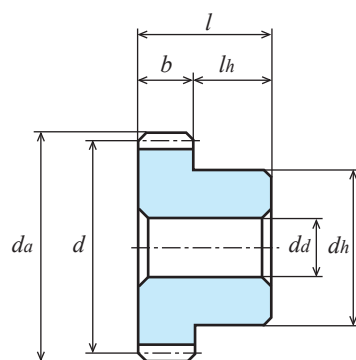

B1 type [-]

Number of teeth <i>z</i>	Face width <i>b</i>	Allowable transfer capability table for different revolutions per minute, Bending strength, (Unit: kW)							Allowable torque for input revolutions per minute (Unit: N·m)
		10rpm	100rpm	200rpm	400rpm	800rpm	1,200rpm	1,500rpm	100rpm
14	35	0.139	1.39	2.79	5.58	10.01	13.43	15.91	132.74
15	30	0.134	1.34	2.68	5.36	9.46	12.61	15.14	127.96
16	22	0.11	1.09	2.18	4.36	7.57	10.06	12.22	104.09
16	30	0.15	1.49	2.97	5.94	10.33	13.71	16.66	142.29
18	22	0.13	1.31	2.62	5.14	8.81	11.91	14.43	125.10
18	30	0.18	1.79	3.57	7.01	12.02	16.25	19.68	170.93
20	22	0.15	1.54	3.08	5.93	10.03	13.79	16.65	147.06
20	30	0.210	2.110	4.230	8.140	13.780	18.950	22.880	201.50
24	22	0.20	2.01	4.01	7.45	12.33	17.49	21.16	191.94
24	30	0.27	2.73	5.47	10.17	16.82	23.85	28.85	260.70
24	35	0.32	3.19	6.38	11.86	19.62	27.82	33.66	304.63
25	22	0.21	2.12	4.25	7.83	13.01	18.40	22.29	202.45
25	30	0.290	2.910	5.820	10.710	17.800	25.180	30.510	277.90
25	35	0.34	3.38	6.76	12.46	20.69	29.28	35.47	322.78
28	22	0.25	2.49	4.98	8.93	15.01	21.18	25.68	237.78
28	30	0.34	3.39	6.78	12.18	20.47	28.89	35.02	323.73
30	22	0.27	2.73	5.46	9.65	16.33	23.05	27.89	260.70
30	30	0.370	3.730	7.460	13.170	22.290	31.470	38.070	356.20
32	20	0.27	2.71	5.41	9.41	16.03	22.65	27.36	258.79
32	30	0.41	4.06	8.12	14.11	24.05	33.98	41.04	387.71
32	32	0.43	4.33	8.66	15.05	25.66	36.25	43.78	413.50

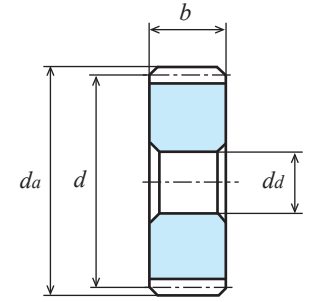
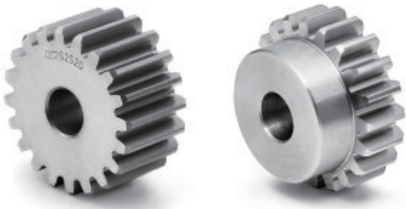

Unit: mm

Accuracy Class	Material	Pressure angle	Heat treatment	Tooth surface hardness	Backlash ①
[JIS B 1702-1] N8	S45C	20°	—	—	0.12 to 0.3

★ No surface treatment is applied.

★ This allowable transfer capability table was prepared by using the formulas presented by the JGMA (Japan Gear Manufacturers Association).  
For the unit conversion method, refer to P. 20 in "References."

★ KG standard products have different transfer capabilities depending on whether the face width is "Standard" (for light loads) or "Wide" (for heavy loads).

① This is a theoretical value obtained when a pair of gears of the same type and material are meshed with each other.

A1 type [-]

Catalogue number	Number of teeth $z$	Reference diameter $d$	Tip diameter $d_a$	Type	Face width $b$	Hole diameter $d_a(H7)$	Hub diameter $d_h$	Hub length $l_h$	Overall length $l$	Weight $W(kg)$
S3S 36A – 2020F	36	φ108	φ114	A1	20	φ20	-	-	20	1.39
S3S 36B – 2020	36	φ108	φ114	B1	20	φ20	φ50	13	33	1.56
S3S 40A – 2020F	40	φ120	φ126	A1	20	φ20	-	-	20	1.73
S3S 40A – 3222F	40	φ120	φ126	A1	32	φ22	-	-	32	2.75
S3S 40B – 2020	40	φ120	φ126	B1	20	φ20	φ50	13	33	1.90
S3S 40B – 3025N	40	φ120	φ126	B1	30	φ25	φ70	13	43	2.89
S3S 40B – 3222	40	φ120	φ126	B1	32	φ22	φ60	13	45	3.00
S3S 48A – 2020F	48	φ144	φ150	A1	20	φ20	-	-	20	2.51
S3S 48A – 3222F	48	φ144	φ150	A1	32	φ22	-	-	32	4.00
S3S 48B – 2020	48	φ144	φ150	B1	20	φ20	φ50	13	33	2.68
S3S 48B – 3025N	48	φ144	φ150	B1	30	φ25	φ80	13	43	4.19
S3S 50A – 2020F	50	φ150	φ156	A1	20	φ20	-	-	20	2.73
S3S 50A – 3222F	50	φ150	φ156	A1	32	φ22	-	-	32	4.34
S3S 50B – 2020	50	φ150	φ156	B1	20	φ20	φ60	13	33	2.98
S3S 50B – 3025N	50	φ150	φ156	B1	30	φ25	φ80	13	43	4.51
S3S 56A – 3222F	56	φ168	φ174	A1	32	φ22	-	-	32	5.47
S3S 60A – 2020F	60	φ180	φ186	A1	20	φ20	-	-	20	3.95
S3S 60A – 3222F	60	φ180	φ186	A1	32	φ22	-	-	32	6.30
S3S 60B – 2022	60	φ180	φ186	B1	20	φ22	φ60	13	33	4.19



2D • 3D CAD

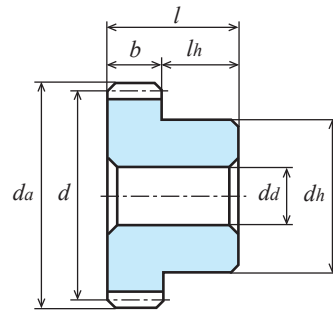

B1 type [-]

Number of teeth $z$	Face width $b$	Allowable transfer capability table for different revolutions per minute, Bending strength, (Unit: kW)							Allowable torque for input revolutions per minute (Unit: N·m)
		10rpm	100rpm	200rpm	400rpm	800rpm	1,200rpm	1,500rpm	100rpm
36	20	0.32	3.16	6.20	10.64	18.39	26.00	31.63	301.77
40	20	0.36	3.62	6.98	11.81	20.69	29.29	36.23	345.69
40	30	0.540	5.420	10.440	17.680	30.970	43.830	54.230	517.59
40	32	0.58	5.80	11.16	18.90	33.11	46.86	57.97	553.88
48	20	0.46	4.55	8.46	14.00	25.40	36.43	-	434.51
48	30	0.68	6.83	12.69	21.01	38.10	54.65	-	652.24
48	32	0.73	7.29	13.54	22.41	40.64	58.29	-	696.17
50	20	0.48	4.79	8.82	14.66	26.56	38.31	-	457.43
50	30	0.720	7.150	13.180	21.890	39.670	57.230	-	682.80
50	32	0.77	7.66	14.12	23.45	42.49	61.30	-	731.50
56	32	0.88	8.80	15.80	26.54	47.95	-	-	840.37
60	20	0.60	5.98	10.55	17.86	32.20	-	-	571.07
60	32	0.96	9.56	16.88	28.57	51.52	-	-	912.95



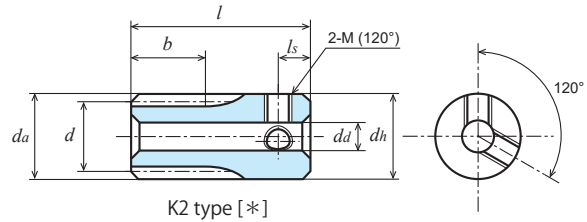

Unit: mm

Accuracy Class	Material	Pressure angle	Heat treatment	Tooth surface hardness	Backlash ①
[JIS B 1702-1] N9	SUS304	20°	—	—	0.02 to 0.06

★ No surface treatment is applied. Gears with a [\*] are provided with two screw holes. No set screws are provided.

★ This allowable transfer capability table was prepared by using the formulas presented by the JGMA (Japan Gear Manufacturers Association).

For the unit conversion method, refer to P. 20 in "References."

① This is a theoretical value obtained when a pair of gears of the same type and material are meshed with each other.

Catalogue number	Number of teeth <i>z</i>	Refer- ence diameter <i>d</i>	Tip diameter <i>da</i>	Type	Face width <i>b</i>	Hole diameter <i>da</i> (H8)	Hub diameter <i>dh</i>	Hub length <i>lh</i>	Overall length <i>l</i>	Screw		Weight <i>W</i> (g)
										2-M(120°)	<i>ls</i>	
S50SU 10K — 1006	10	φ 5	φ 6	K1	10	-	φ 6	45	55	-	-	11.7
S50SU 12K — 1007	12	φ 6	φ 7	K1	10	-	φ 7	45	55	-	-	16.0
S50SU 14K — 1008	14	φ 7	φ 8	K1	10	-	φ 8	45	55	-	-	21.0
S50SU 15K — 1008	15	φ 7.5	φ 8.5	K1	10	-	φ 8.5	45	55	-	-	23.8
S50SU 16K * 0804	16	φ 8	φ 9	K2	8	φ 4	φ 9	10	18	2-M3	3	6.2
S50SU 16L — 0805	16	φ 8	φ 9	L1	8	-	φ 5 (h9)	L22 R50	80	-	-	14.4
S50SU 18K * 0804	18	φ 9	φ 10	K2	8	φ 4	φ 10	10	18	2-M3	3	8.2
S50SU 18L — 0806	18	φ 9	φ 10	L1	8	-	φ 6 (h9)	L22 R50	80	-	-	20.2
S50SU 20K * 0804	20	φ 10	φ 11	K2	8	φ 4	φ 11	10	18	2-M3	3	10.4
S50SU 20L — 0806	20	φ 10	φ 11	L1	8	-	φ 6 (h9)	L22 R50	80	-	-	21.1
S50SU 24K * 0805	24	φ 12	φ 13	K2	8	φ 5	φ 13	10	18	2-M3	3	14.5
S50SU 25K * 0805	25	φ 12.5	φ 13.5	K2	8	φ 5	φ 13.5	10	18	2-M3	3	15.9
S50SU 28K * 0805	28	φ 14	φ 15	K2	8	φ 5	φ 15	10	18	2-M3	3	20.5
S50SU 30K * 0806	30	φ 15	φ 16	K2	8	φ 6	φ 16	10	18	2-M3	3	22.7
S50SU 32B * 0506	32	φ 16	φ 17	B1	5	φ 6	φ 12	8	13	2-M3	4	12.0
S50SU 36B * 0506	36	φ 18	φ 19	B1	5	φ 6	φ 12	8	13	2-M3	4	14.1
S50SU 40B * 0506	40	φ 20	φ 21	B1	5	φ 6	φ 15	8	13	2-M4	4	20.0
S50SU 45B * 0506	45	φ 22.5	φ 23.5	B1	5	φ 6	φ 15	8	13	2-M4	4	23.3
S50SU 48B * 0506	48	φ 24	φ 25	B1	5	φ 6	φ 15	8	13	2-M4	4	25.5
S50SU 50B * 0506	50	φ 25	φ 26	B1	5	φ 6	φ 15	8	13	2-M4	4	27.0
S50SU 54B * 0506	54	φ 27	φ 28	B1	5	φ 6	φ 15	8	13	2-M4	4	30.3
S50SU 56B * 0506	56	φ 28	φ 29	B1	5	φ 6	φ 15	8	13	2-M4	4	32.0
S50SU 60B * 0508	60	φ 30	φ 31	B1	5	φ 8	φ 18	8	13	2-M4	4	38.2
S50SU 64B * 0508	64	φ 32	φ 33	B1	5	φ 8	φ 18	8	13	2-M4	4	42.0
S50SU 70B * 0508	70	φ 35	φ 36	B1	5	φ 8	φ 18	8	13	2-M4	4	48.3
S50SU 72B * 0508	72	φ 36	φ 37	B1	5	φ 8	φ 18	8	13	2-M4	4	50.5
S50SU 75B * 0508	75	φ 37.5	φ 38.5	B1	5	φ 8	φ 18	8	13	2-M4	4	53.9
S50SU 80B * 0510	80	φ 40	φ 41	B1	5	φ 10	φ 22	8	13	2-M5	4	64.3
S50SU 90B * 0510	90	φ 45	φ 46	B1	5	φ 10	φ 22	8	13	2-M5	4	77.5
S50SU 100B * 0510	100	φ 50	φ 51	B1	5	φ 10	φ 25	8	13	2-M5	4	98.9
S50SU 120B * 0510	120	φ 60	φ 61	B1	5	φ 10	φ 25	8	13	2-M5	4	133.2

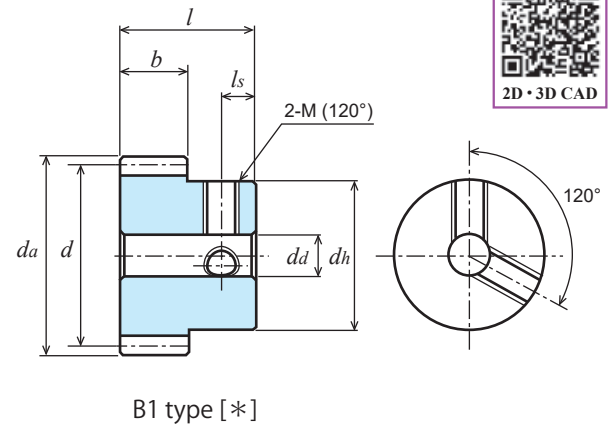
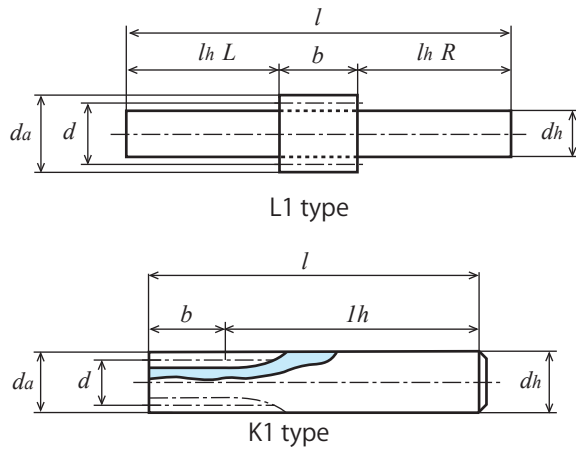

Catalogue number	Allowable transfer capability table for different revolutions per minute, Bending strength, (Unit: W)						
	10rpm	100rpm	200rpm	400rpm	800rpm	1,200rpm	1,500rpm
S50SU 10K — 1006	0.30	3.03	6.06	12.12	24.24	36.37	45.46
S50SU 12K — 1007	0.42	4.24	8.49	16.98	33.96	50.93	63.67
S50SU 14K — 1008	0.55	5.53	11.07	22.13	44.26	66.39	82.99
S50SU 15K — 1008	0.62	6.20	12.40	24.80	49.60	74.41	93.01
S50SU 16K * 0804	0.55	5.50	11.01	22.02	44.04	66.06	82.57
S50SU 16L — 0805	0.55	5.50	11.01	22.02	44.04	66.06	82.57
S50SU 18K * 0804	0.66	6.62	13.24	26.47	52.94	79.41	99.26
S50SU 18L — 0806	0.66	6.62	13.24	26.47	52.94	79.41	99.26
S50SU 20K * 0804	0.78	7.77	15.54	31.08	62.16	93.24	116.55
S50SU 20L — 0806	0.78	7.77	15.54	31.08	62.16	93.24	116.55
S50SU 24K * 0805	1.01	10.13	20.26	40.52	81.04	121.55	151.94
S50SU 25K * 0805	1.07	10.73	21.46	42.93	85.86	128.79	160.96
S50SU 28K * 0805	1.26	12.56	25.13	50.26	100.52	150.77	185.69
S50SU 30K * 0806	1.38	13.80	27.59	55.18	110.37	165.55	201.56
S50SU 32B * 0506	0.94	9.40	18.81	37.61	75.22	112.74	135.81
S50SU 36B * 0506	1.10	10.98	21.96	43.93	87.85	129.24	155.10
S50SU 40B * 0506	1.26	12.58	25.16	50.32	100.65	145.37	173.83
S50SU 45B * 0506	1.46	14.59	29.18	58.37	116.74	164.87	196.29
S50SU 48B * 0506	1.58	15.81	31.63	63.25	126.40	176.32	209.39
S50SU 50B * 0506	1.66	16.63	33.26	66.52	132.10	183.82	217.95
S50SU 54B * 0506	1.83	18.27	36.54	73.08	143.35	198.52	234.63
S50SU 56B * 0506	1.91	19.10	38.19	76.38	148.90	205.71	242.76
S50SU 60B * 0508	2.07	20.75	41.50	83.00	159.84	219.81	258.63
S50SU 64B * 0508	2.24	22.41	44.82	89.64	170.57	233.52	273.96
S50SU 70B * 0508	2.49	24.91	49.82	99.65	186.27	253.37	296.02
S50SU 72B * 0508	2.57	25.75	51.50	102.99	191.40	259.80	303.14
S50SU 75B * 0508	2.70	27.01	54.01	108.02	199.00	269.28	313.58
S50SU 80B * 0510	2.91	29.11	58.21	116.42	211.43	284.66	334.02
S50SU 90B * 0510	3.33	33.28	66.56	133.13	235.05	313.46	376.29
S50SU 100B * 0510	3.75	37.50	75.01	148.96	257.73	344.32	417.84
S50SU 120B * 0510	4.60	45.99	91.98	177.13	299.84	412.29	497.84

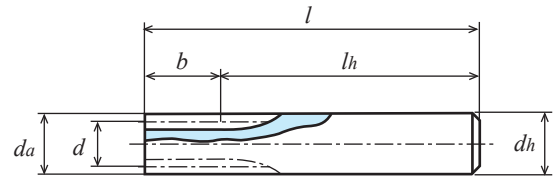

K1 type

Unit: mm

Accuracy Class	Material	Pressure angle	Heat treatment	Tooth surface hardness	Backlash ①
[JIS B 1702-1] N9	SUS304	20°	—	—	0.02 to 0.06

★ No surface treatment is applied. Gears with a [+] are provided with one screw holes. No set screws are provided.

★ This allowable transfer capability table was prepared by using the formulas presented by the JGMA (Japan Gear Manufacturers Association). For the unit conversion method, refer to P. 20 in "References."

① This is a theoretical value obtained when a pair of gears of the same type and material are meshed with each other.

Catalogue number	Number of teeth $z$	Refer- ence diameter $d$	Tip diameter $d_a$	Type	Face width $b$	Hole diameter $d_a(H8)$	Hub diameter $d_h$	Hub length $l_h$	Overall length $l$	Screw		Weight $W(g)$
										$M$	$l_s$	
<b>S75SU 10K – 0809</b>	10	$\phi$ 7.5	$\phi$ 9	K1	8	-	$\phi$ 9	47	55	-	-	26.5
<b>S75SU 14K + 0805</b>	14	$\phi$ 10.5	$\phi$ 12	K2	8	$\phi$ 5	$\phi$ 12	12	20	M3	3	13.0
<b>S75SU 15K + 0805</b>	15	$\phi$ 11.25	$\phi$ 12.75	K2	8	$\phi$ 5	$\phi$ 12.75	12	20	M3	3	15.2
<b>S75SU 16B + 0805</b>	16	$\phi$ 12	$\phi$ 13.5	B1	8	$\phi$ 5	$\phi$ 10	7	15	M3	3.5	9.1
<b>S75SU 20B + 0806</b>	20	$\phi$ 15	$\phi$ 16.5	B1	8	$\phi$ 6	$\phi$ 12	7	15	M4	3.5	13.9
<b>S75SU 22B + 0806</b>	22	$\phi$ 16.5	$\phi$ 18	B1	8	$\phi$ 6	$\phi$ 12	7	15	M4	3.5	16.3
<b>S75SU 24B + 0806</b>	24	$\phi$ 18	$\phi$ 19.5	B1	8	$\phi$ 6	$\phi$ 14	7	15	M4	3.5	21.0
<b>S75SU 25B + 0806</b>	25	$\phi$ 18.75	$\phi$ 20.25	B1	8	$\phi$ 6	$\phi$ 14	7	15	M4	3.5	22.4
<b>S75SU 26B + 0806</b>	26	$\phi$ 19.5	$\phi$ 21	B1	8	$\phi$ 6	$\phi$ 14	7	15	M4	3.5	23.8
<b>S75SU 28B + 0806</b>	28	$\phi$ 21	$\phi$ 22.5	B1	8	$\phi$ 6	$\phi$ 14	7	15	M4	3.5	26.9
<b>S75SU 48B + 0606</b>	48	$\phi$ 36	$\phi$ 37.5	B1	6	$\phi$ 6	$\phi$ 20	9	15	M4	4	67.0



2D • 3D CAD

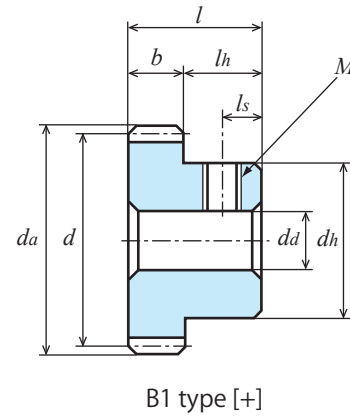
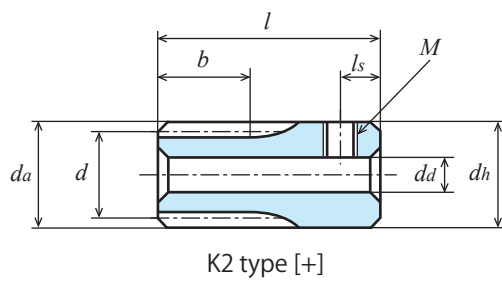

Catalogue number	Allowable transfer capability table for different revolutions per minute, Bending strength, (Unit: W)						
	10rpm	100rpm	200rpm	400rpm	800rpm	1,200rpm	1,500rpm
<b>S75SU 10K – 0809</b>	0.55	5.46	10.91	21.82	43.64	65.46	81.83
<b>S75SU 14K + 0805</b>	1.00	9.96	19.92	39.84	79.67	119.51	149.39
<b>S75SU 15K + 0805</b>	1.12	11.16	22.32	44.64	89.29	133.93	167.41
<b>S75SU 16B + 0805</b>	1.24	12.39	24.77	49.54	99.09	148.63	185.79
<b>S75SU 20B + 0806</b>	1.75	17.48	34.97	69.93	139.86	209.79	255.42
<b>S75SU 22B + 0806</b>	2.01	20.12	40.23	80.46	160.93	240.07	288.91
<b>S75SU 24B + 0806</b>	2.28	22.79	45.58	91.17	182.33	268.23	321.89
<b>S75SU 25B + 0806</b>	2.41	24.15	48.30	96.59	193.18	282.23	338.23
<b>S75SU 26B + 0806</b>	2.55	25.51	51.03	102.05	204.11	296.15	354.44
<b>S75SU 28B + 0806</b>	2.83	28.27	56.54	113.08	226.16	323.73	386.41
<b>S75SU 48B + 0606</b>	4.27	42.69	85.39	170.78	317.37	430.79	502.63

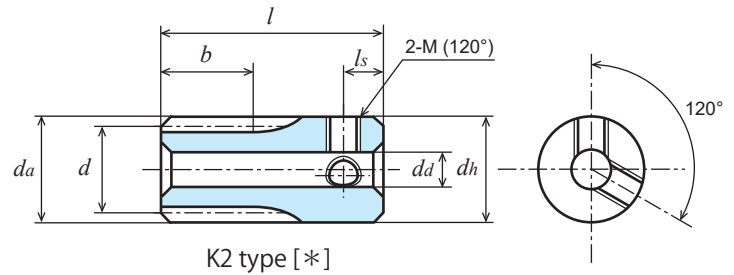

K2 type [\*]

Unit: mm

Accuracy Class	Material	Pressure angle	Heat treatment	Tooth surface hardness	Backlash ①
[JIS B 1702-1] N9	SUS304	20°	—	—	0.02 to 0.06

★ No surface treatment is applied. Gears with a [\*] are provided with two screw holes. No set screws are provided.

★ This allowable transfer capability table was prepared by using the formulas presented by the JGMA (Japan Gear Manufacturers Association). For the unit conversion method, refer to P. 20 in "References."

① This is a theoretical value obtained when a pair of gears of the same type and material are meshed with each other.

Catalogue number	Number of teeth <i>z</i>	Refer- ence diameter <i>d</i>	Tip diameter <i>da</i>	Type	Face width <i>b</i>	Hole diameter <i>da</i> (H8)	Hub diameter <i>dh</i>	Hub length <i>lh</i>	Overall length <i>l</i>	Screw		Weight <i>W</i> (g)
										2-M(120°)	<i>ls</i>	
S80SU 10K — 1010	10	φ 8	φ 9.6	K1	10	-	φ10	50	60	-	-	35.1
S80SU 12K — 1012	12	φ 9.6	φ11.2	K1	10	-	φ12	50	60	-	-	50.6
S80SU 14K * 0704	14	φ11.2	φ12.8	K2	7	φ 4	φ12.8	13	20	2-M3	3	16.3
S80SU 15K * 0704	15	φ12	φ13.6	K2	7	φ 4	φ13.6	13	20	2-M3	3	18.8
S80SU 16L — 0706	16	φ12.8	φ14.4	L1	7	-	φ 6 (h9)	L28 R60	95	-	-	26.9
S80SU 16B * 0504	16	φ12.8	φ14.4	B1	5	φ 4	φ10	7	12	2-M3	3	8.0
S80SU 16B * 0704	16	φ12.8	φ14.4	B1	7	φ 4	φ10	7	14	2-M3	3	9.8
S80SU 18B * 0704	18	φ14.4	φ16	B1	7	φ 4	φ10	7	14	2-M3	3	11.7
S80SU 20L — 0710	20	φ16	φ17.6	L1	7	-	φ10 (h9)	L28 R60	95	-	-	66.0
S80SU 20B * 0504	20	φ16	φ17.6	B1	5	φ 4	φ10	7	12	2-M3	3	10.9
S80SU 20B * 0704	20	φ16	φ17.6	B1	7	φ 4	φ10	7	14	2-M3	3	13.9
S80SU 22B * 0504	22	φ17.6	φ19.2	B1	5	φ 4	φ10	7	12	2-M3	3	12.5
S80SU 22B * 0704	22	φ17.6	φ19.2	B1	7	φ 4	φ10	7	14	2-M3	3	16.2
S80SU 24B * 0505	24	φ19.2	φ20.8	B1	5	φ 5	φ15	7	12	2-M4	4	18.6
S80SU 24B * 0705	24	φ19.2	φ20.8	B1	7	φ 5	φ15	7	14	2-M4	4	22.9
S80SU 25B * 0505	25	φ20	φ21.6	B1	5	φ 5	φ15	7	12	2-M4	4	19.6
S80SU 25B * 0705	25	φ20	φ21.6	B1	7	φ 5	φ15	7	14	2-M4	4	24.2
S80SU 28B * 0505	28	φ22.4	φ24	B1	5	φ 5	φ15	7	12	2-M4	4	22.7
S80SU 28B * 0705	28	φ22.4	φ24	B1	7	φ 5	φ15	7	14	2-M4	4	28.7
S80SU 30B * 0505	30	φ24	φ25.6	B1	5	φ 5	φ15	7	12	2-M4	4	25.0
S80SU 30B * 0705	30	φ24	φ25.6	B1	7	φ 5	φ15	7	14	2-M4	4	31.9
S80SU 32B * 0505	32	φ25.6	φ27.2	B1	5	φ 5	φ15	9	14	2-M4	4	30.0
S80SU 36B * 0506	36	φ28.8	φ30.4	B1	5	φ 6	φ18	9	14	2-M4	4	39.9
S80SU 40B * 0506	40	φ32	φ33.6	B1	5	φ 6	φ18	9	14	2-M4	4	45.9
S80SU 45B * 0506	45	φ36	φ37.6	B1	5	φ 6	φ18	9	14	2-M4	4	54.4
S80SU 48B * 0506	48	φ38.4	φ40	B1	5	φ 6	φ18	9	14	2-M4	4	59.9
S80SU 50B * 0506	50	φ40	φ41.6	B1	5	φ 6	φ18	9	14	2-M4	4	63.9
S80SU 54B * 0506	54	φ43.2	φ44.8	B1	5	φ 6	φ18	9	14	2-M4	4	72.1
S80SU 60B * 0506	60	φ48	φ49.6	B1	5	φ 6	φ18	9	14	2-M4	4	85.8
S80SU 64B * 0506	64	φ51.2	φ52.8	B1	5	φ 6	φ18	9	14	2-M4	4	95.7
S80SU 70B * 0508	70	φ56	φ57.6	B1	5	φ 8	φ28	9	14	2-M4	4	134.4
S80SU 72B * 0508	72	φ57.6	φ59.2	B1	5	φ 8	φ28	9	14	2-M4	4	140.0
S80SU 80B * 0508	80	φ64	φ65.6	B1	5	φ 8	φ28	9	14	2-M4	4	164.3
S80SU 90B * 0508	90	φ72	φ73.6	B1	5	φ 8	φ28	9	14	2-M4	4	198.1
S80SU 100B * 0508	100	φ80	φ81.6	B1	5	φ 8	φ28	9	14	2-M4	4	236.0
S80SU 100B * 0510	100	φ80	φ81.6	B1	5	φ10	φ28	9	14	2-M4	4	233.0

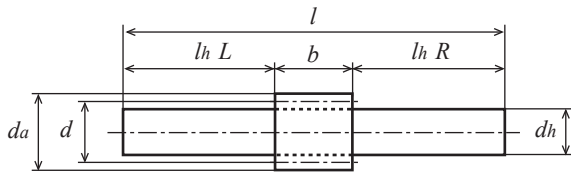

L1 type

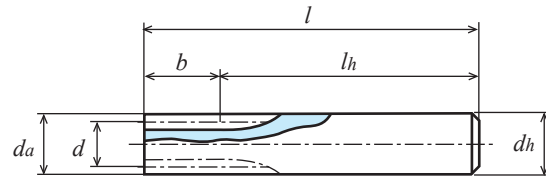

K1 type

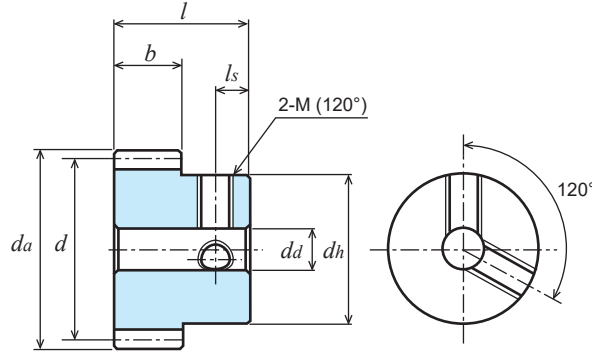

B1 type [\*]



2D • 3D CAD

Catalogue number	Allowable transfer capability table for different revolutions per minute, Bending strength, (Unit: W)						
	10rpm	100rpm	200rpm	400rpm	800rpm	1,200rpm	1,500rpm
S80SU 10K – 1010	0.78	7.76	15.52	31.03	62.07	93.10	116.37
S80SU 12K – 1012	1.09	10.87	21.73	43.46	86.93	130.39	162.99
S80SU 14K * 0704	0.99	9.91	19.83	39.66	79.32	118.98	148.72
S80SU 15K * 0704	1.11	11.11	22.22	44.45	88.89	133.34	166.67
S80SU 16L – 0706	1.23	12.33	24.66	49.32	98.65	147.97	184.82
S80SU 16B * 0504	0.88	8.81	17.62	35.23	70.46	105.70	132.01
S80SU 16B * 0704	1.23	12.33	24.66	49.32	98.65	147.97	184.82
S80SU 18B * 0704	1.48	14.82	29.65	59.29	118.59	177.88	218.07
S80SU 20L – 0710	1.74	17.40	34.81	69.62	139.24	208.69	251.40
S80SU 20B * 0504	1.24	12.43	24.86	49.73	99.46	149.07	179.57
S80SU 20B * 0704	1.74	17.40	34.81	69.62	139.24	208.69	251.40
S80SU 22B * 0504	1.43	14.30	28.61	57.22	114.44	168.97	202.93
S80SU 22B * 0704	2.00	20.03	40.05	80.10	160.21	236.56	284.10
S80SU 24B * 0505	1.62	16.21	32.41	64.83	129.66	188.65	225.90
S80SU 24B * 0705	2.27	22.69	45.38	90.76	181.52	264.10	316.25
S80SU 25B * 0505	1.72	17.17	34.34	68.69	137.37	198.42	237.26
S80SU 25B * 0705	2.40	24.04	48.08	96.16	192.32	277.79	332.16
S80SU 28B * 0505	2.10	20.10	40.21	80.41	160.83	227.34	270.71
S80SU 28B * 0705	2.81	28.14	56.29	112.58	225.16	318.28	379.00
S80SU 30B * 0505	2.21	22.07	44.15	88.30	176.45	246.13	292.31
S80SU 30B * 0705	3.09	30.90	61.81	123.61	247.03	344.58	409.23
S80SU 32B * 0505	2.41	24.07	48.14	96.28	190.50	264.69	313.54
S80SU 36B * 0506	2.81	28.11	56.23	112.45	218.15	300.82	354.57
S80SU 40B * 0506	3.22	32.21	64.41	128.83	245.14	335.60	393.73
S80SU 45B * 0506	3.74	37.36	74.71	149.42	277.69	376.92	439.78
S80SU 48B * 0506	4.05	40.48	80.96	161.92	296.75	400.82	466.79
S80SU 50B * 0506	4.26	42.57	85.14	170.29	309.24	416.36	488.56
S80SU 54B * 0506	4.68	46.77	93.55	187.10	333.68	446.48	531.67
S80SU 60B * 0506	5.31	53.12	106.24	212.30	369.00	490.02	595.27
S80SU 64B * 0506	5.74	57.37	114.74	227.01	391.70	525.18	636.94
S80SU 70B * 0508	6.38	63.77	127.55	248.65	424.50	577.17	698.30
S80SU 72B * 0508	6.59	65.92	131.83	255.75	435.12	594.31	718.46
S80SU 80B * 0508	7.45	74.51	149.02	283.56	476.06	661.79	797.82
S80SU 90B * 0508	8.52	85.20	170.40	316.67	523.99	742.92	898.85
S80SU 100B * 0508	9.60	96.01	192.03	348.72	582.97	822.44	998.20
S80SU 100B * 0510	9.60	96.01	192.03	348.72	582.97	822.44	998.20

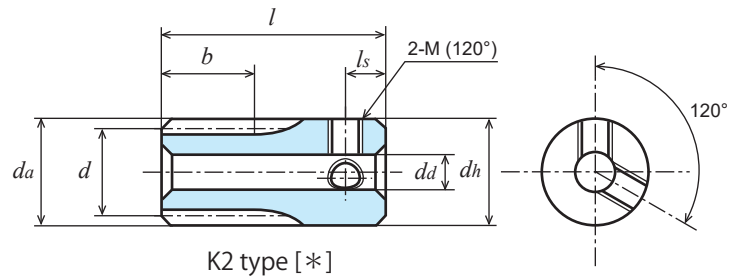
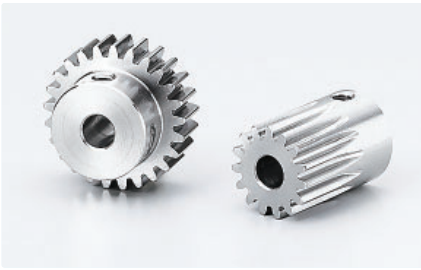

K2 type [\*]

Unit: mm

Accuracy Class	Material	Pressure angle	Heat treatment	Tooth surface hardness	Backlash ①
[JIS B 1702-1] N9	SUS304	20°	—	—	0.06 to 0.12

★ No surface treatment is applied. Gears with a [\*] are provided with two screw holes. No set screws are provided.

★ This allowable transfer capability table was prepared by using the formulas presented by the JGMA (Japan Gear Manufacturers Association).

For the unit conversion method, refer to P. 20 in "References."

① This is a theoretical value obtained when a pair of gears of the same type and material are meshed with each other.

Catalogue number	Number of teeth <i>z</i>	Refer-ence diameter <i>d</i>	Tip diameter <i>da</i>	Type	Face width <i>b</i>	Hole diameter <i>da</i> (H8)	Hub diameter <i>dh</i>	Hub length <i>lh</i>	Overall length <i>l</i>	Screw		Weight <i>W</i> (g)
										2-M(120°)	<i>ls</i>	
S1SU 14K * 0806	14	φ 14	φ 16	K2	8	φ 6	φ16	17	25	2-M4	4	30.4
S1SU 15K * 0806	15	φ 15	φ 17	K2	8	φ 6	φ17	17	25	2-M4	4	35.3
S1SU 16K * 0806	16	φ 16	φ 18	K2	8	φ 6	φ18	17	25	2-M4	4	40.5
S1SU 17B * 0806	17	φ 17	φ 19	B1	8	φ 6	φ14	8	16	2-M4	4	19.9
S1SU 18B * 0806	18	φ 18	φ 20	B1	8	φ 6	φ14	8	16	2-M4	4	21.7
S1SU 18B * 1006	18	φ 18	φ 20	B1	10	φ 6	φ14	10	20	2-M4	4	27.2
S1SU 20B * 0806	20	φ 20	φ 22	B1	8	φ 6	φ16	8	16	2-M4	4	28.3
S1SU 20B * 1006	20	φ 20	φ 22	B1	10	φ 6	φ16	10	20	2-M4	4	35.5
S1SU 22B * 0806	22	φ 22	φ 24	B1	8	φ 6	φ18	8	16	2-M4	4	35.7
S1SU 24B * 0806	24	φ 24	φ 26	B1	8	φ 6	φ18	8	16	2-M4	4	40.3
S1SU 24B * 1006	24	φ 24	φ 26	B1	10	φ 6	φ18	10	20	2-M4	4	50.6
S1SU 25B * 0806	25	φ 25	φ 27	B1	8	φ 6	φ18	8	16	2-M4	4	42.7
S1SU 25B * 1006	25	φ 25	φ 27	B1	10	φ 6	φ20	10	20	2-M4	4	58.2
S1SU 26B * 0806	26	φ 26	φ 28	B1	8	φ 6	φ20	8	16	2-M4	4	48.9
S1SU 28B * 0806	28	φ 28	φ 30	B1	8	φ 6	φ20	8	16	2-M4	4	54.2
S1SU 28B * 1006	28	φ 28	φ 30	B1	10	φ 6	φ20	10	20	2-M4	4	68.1
S1SU 30B * 0806	30	φ 30	φ 32	B1	8	φ 6	φ24	8	16	2-M4	4	68.5
S1SU 30B * 1006	30	φ 30	φ 32	B1	10	φ 6	φ24	10	20	2-M4	4	86.0
S1SU 32B * 0606	32	φ 32	φ 34	B1	6	φ 6	φ24	10	16	2-M4	4	69.1
S1SU 34B * 0606	34	φ 34	φ 36	B1	6	φ 6	φ24	10	16	2-M4	4	74.0
S1SU 35B * 0606	35	φ 35	φ 37	B1	6	φ 6	φ24	10	16	2-M4	4	76.6
S1SU 36B * 0608	36	φ 36	φ 38	B1	6	φ 8	φ24	10	16	2-M4	4	76.6
S1SU 40B * 0608	40	φ 40	φ 42	B1	6	φ 8	φ28	10	16	2-M4	4	100.6
S1SU 44B * 0608	44	φ 44	φ 46	B1	6	φ 8	φ28	10	16	2-M4	4	113.1
S1SU 50B * 0608	50	φ 50	φ 52	B1	6	φ 8	φ28	10	16	2-M4	4	134.2
S1SU 54B * 0608	54	φ 54	φ 56	B1	6	φ 8	φ28	10	16	2-M5	5	148.8
S1SU 60B * 0610	60	φ 60	φ 62	B1	6	φ10	φ30	10	16	2-M5	5	178.0
S1SU 64B * 0610	64	φ 64	φ 66	B1	6	φ10	φ30	10	16	2-M5	5	196.5
S1SU 70B * 0610	70	φ 70	φ 72	B1	6	φ10	φ30	10	16	2-M5	5	226.6
S1SU 72B * 0610	72	φ 72	φ 74	B1	6	φ10	φ30	10	16	2-M5	5	237.2
S1SU 80B * 0610	80	φ 80	φ 82	B1	6	φ10	φ30	10	16	2-M5	5	282.6
S1SU 90B * 0610	90	φ 90	φ 92	B1	6	φ10	φ30	10	16	2-M5	5	346.1
S1SU 100B * 0610	100	φ100	φ102	B1	6	φ10	φ30	10	16	2-M5	5	417.1
S1SU 120B * 0610	120	φ120	φ122	B1	6	φ10	φ30	10	16	2-M5	5	581.6



2D • 3D CAD

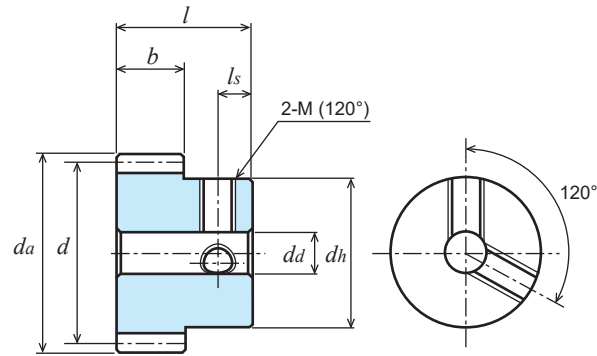

B1 type [\*]

Catalogue number	Allowable transfer capability table for different revolutions per minute, Bending strength, (Unit: W)						
	10rpm	100rpm	200rpm	400rpm	800rpm	1,200rpm	1,500rpm
S1SU 14K * 0806	1.77	17.71	35.41	70.82	141.64	212.46	261.67
S1SU 15K * 0806	1.98	19.84	39.68	79.37	158.73	238.10	289.88
S1SU 16K * 0806	2.20	22.02	44.04	88.08	176.16	264.03	318.05
S1SU 17B * 0806	2.42	24.23	48.46	96.92	193.84	287.82	346.06
S1SU 18B * 0806	2.65	26.47	52.94	105.88	211.76	311.52	373.85
S1SU 18B * 1006	3.31	33.09	66.18	132.35	264.70	389.40	467.32
S1SU 20B * 0806	3.11	31.08	62.16	124.32	248.64	359.14	429.43
S1SU 20B * 1006	3.89	38.85	77.70	155.40	310.80	448.92	536.79
S1SU 22B * 0806	3.58	35.76	71.52	143.04	286.09	405.86	483.62
S1SU 24B * 0806	4.05	40.52	81.04	162.07	323.88	451.79	536.54
S1SU 24B * 1006	5.06	50.65	101.29	202.59	404.85	564.74	670.68
S1SU 25B * 0806	4.29	42.93	85.86	171.72	341.02	474.52	562.62
S1SU 25B * 1006	5.37	53.66	107.32	214.65	426.27	593.15	703.28
S1SU 26B * 0806	4.54	45.36	90.71	181.43	358.07	497.04	588.38
S1SU 28B * 0806	5.03	50.26	100.52	201.03	391.90	541.43	638.95
S1SU 28B * 1006	6.28	62.82	125.65	251.29	489.88	676.79	798.68
S1SU 30B * 0806	5.52	55.18	110.37	220.74	425.11	584.61	687.84
S1SU 30B * 1006	6.90	68.98	137.96	275.92	531.39	730.76	859.80
S1SU 32B * 0606	4.51	45.13	90.27	180.53	343.53	470.31	551.76
S1SU 34B * 0606	4.89	48.91	97.82	195.64	367.87	501.44	586.65
S1SU 35B * 0606	5.08	50.81	101.61	203.23	379.90	516.74	603.73
S1SU 36B * 0608	5.27	52.71	105.42	210.85	391.84	531.86	620.57
S1SU 40B * 0608	6.04	60.39	120.78	241.55	438.65	590.59	693.00
S1SU 44B * 0608	6.81	68.10	136.19	272.39	483.61	646.13	772.19
S1SU 50B * 0608	7.98	79.82	159.65	317.05	548.54	732.84	889.33
S1SU 54B * 0608	8.77	87.70	175.40	344.05	589.94	797.50	965.84
S1SU 60B * 0610	9.96	99.60	199.19	383.62	649.37	892.91	1,078.17
S1SU 64B * 0610	10.76	107.57	215.14	409.37	687.26	955.40	1,151.78
S1SU 70B * 0610	11.96	119.58	239.15	447.06	741.67	1,047.46	1,266.18
S1SU 72B * 0610	12.36	123.59	247.19	459.37	760.11	1,077.69	1,303.88
S1SU 80B * 0610	13.97	139.71	279.42	507.42	848.29	1,196.75	1,452.49
S1SU 90B * 0610	15.98	159.75	319.50	564.12	954.81	1,348.27	1,631.26
S1SU 100B * 0610	18.00	180.02	357.51	618.54	1,059.38	1,497.28	1,806.04
S1SU 120B * 0610	22.07	220.74	425.12	719.62	1,260.58	1,784.16	2,207.42



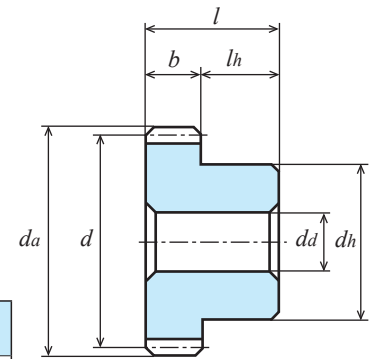

Unit: mm

Accuracy Class	Material	Pressure angle	Heat treatment	Tooth surface hardness	Backlash ①
[JIS B 1702-1] N9	SUS304	20°	—	—	0.09 to 0.18

★ No surface treatment is applied.

★ This allowable transfer capability table was prepared by using the formulas presented by the JGMA (Japan Gear Manufacturers Association).  
For the unit conversion method, refer to P. 20 in "References."

① This is a theoretical value obtained when a pair of gears of the same type and material are meshed with each other.

B1 type [-]

Catalogue number	Number of teeth <i>z</i>	Reference diameter <i>d</i>	Tip diameter <i>da</i>	Type	Face width <i>b</i>	Hole diameter <i>da(H8)</i>	Hub diameter <i>dh</i>	Hub length <i>lh</i>	Overall length <i>l</i>	Weight <i>W(g)</i>
<b>S1.5SU 15B – 1208</b>	15	φ22.5	φ25.5	B1	12	φ 8	φ18	10	22	49.3
<b>S1.5SU 16B – 1208</b>	16	φ24	φ27	B1	12	φ 8	φ20	10	22	59.2
<b>S1.5SU 16B – 1608N</b>	16	φ24	φ27	B1	16	φ 8	φ20	10	26	72.0
<b>S1.5SU 18B – 1210</b>	18	φ27	φ30	B1	12	φ10	φ22	10	22	70.9
<b>S1.5SU 20B – 1210</b>	20	φ30	φ33	B1	12	φ10	φ25	10	22	92.5
<b>S1.5SU 20B – 1610N</b>	20	φ30	φ33	B1	16	φ10	φ25	10	26	112.4
<b>S1.5SU 24B – 1210</b>	24	φ36	φ39	B1	12	φ10	φ30	10	22	139.2
<b>S1.5SU 25B – 1610N</b>	25	φ37.5	φ40.5	B1	16	φ10	φ30	10	26	180.0
<b>S1.5SU 28B – 1210</b>	28	φ42	φ45	B1	12	φ10	φ30	10	22	174.2
<b>S1.5SU 30B – 1210</b>	30	φ45	φ48	B1	12	φ10	φ30	10	22	193.7
<b>S1.5SU 30B – 1610N</b>	30	φ45	φ48	B1	16	φ10	φ30	10	26	241.7
<b>S1.5SU 32B – 1010</b>	32	φ48	φ51	B1	10	φ10	φ30	10	20	187.1
<b>S1.5SU 36B – 1010</b>	36	φ54	φ57	B1	10	φ10	φ30	10	20	225.2
<b>S1.5SU 40B – 1012</b>	40	φ60	φ63	B1	10	φ12	φ36	10	20	287.0
<b>S1.5SU 48B – 1012</b>	48	φ72	φ75	B1	10	φ12	φ36	10	20	385.7
<b>S1.5SU 50B – 1012</b>	50	φ 75	φ 78	B1	10	φ12	φ42	10	20	442.3
<b>S1.5SU 60B – 1014</b>	60	φ 90	φ 93	B1	10	φ14	φ50	10	20	635.8
<b>S1.5SU 80B – 1016</b>	80	φ120	φ123	B1	10	φ16	φ60	10	20	1,089.0
<b>S1.5SU 100B – 1016</b>	100	φ150	φ153	B1	10	φ16	φ60	10	20	1,594.0

Catalogue number	Allowable transfer capability table for different revolutions per minute, Bending strength, (Unit: W)						
	10rpm	100rpm	200rpm	400rpm	800rpm	1,200rpm	1,500rpm
<b>S1.5SU 15B – 1208</b>	6.70	66.97	133.93	267.86	535.73	756.63	900.82
<b>S1.5SU 16B – 1208</b>	7.43	74.32	148.63	297.27	594.06	828.66	984.12
<b>S1.5SU 16B – 1608N</b>	9.91	99.09	198.18	396.36	792.08	1,104.88	1,312.16
<b>S1.5SU 18B – 1210</b>	8.93	89.34	178.67	357.35	700.93	970.64	1,147.22
<b>S1.5SU 20B – 1210</b>	10.49	104.90	209.79	419.58	808.06	1,111.24	1,307.46
<b>S1.5SU 20B – 1610N</b>	13.99	139.86	279.72	559.44	1,077.41	1,481.65	1,743.28
<b>S1.5SU 24B – 1210</b>	13.67	136.75	273.50	546.99	1,016.53	1,379.79	1,609.91
<b>S1.5SU 25B – 1610N</b>	19.32	193.18	386.36	772.72	1,423.55	1,926.29	2,243.17
<b>S1.5SU 28B – 1210</b>	16.96	169.62	339.24	678.48	1,218.22	1,633.80	1,934.94
<b>S1.5SU 30B – 1210</b>	18.62	186.25	372.50	744.99	1,315.37	1,754.13	2,105.74
<b>S1.5SU 30B – 1610N</b>	24.83	248.33	496.66	993.32	1,753.83	2,338.85	2,807.65
<b>S1.5SU 32B – 1010</b>	16.93	169.25	338.50	676.46	1,175.77	1,561.35	1,896.72
<b>S1.5SU 36B – 1010</b>	19.77	197.67	395.34	775.44	1,329.66	1,797.47	2,176.88
<b>S1.5SU 40B – 1012</b>	22.65	226.45	452.91	872.24	1,476.48	2,030.22	2,451.46
<b>S1.5SU 48B – 1012</b>	28.46	284.63	569.25	1,057.90	1,750.48	2,481.86	3,002.75
<b>S1.5SU 50B – 1012</b>	29.93	299.34	598.67	1,102.91	1,832.09	2,592.36	3,140.56
<b>S1.5SU 60B – 1014</b>	37.35	373.48	746.97	1,318.86	2,232.26	3,152.13	3,813.74
<b>S1.5SU 80B – 1016</b>	52.39	523.90	1,008.96	1,707.93	2,991.84	4,234.47	5,239.02
<b>S1.5SU 100B – 1016</b>	67.51	675.07	1,243.66	2,065.89	3,743.17	5,400.57	-

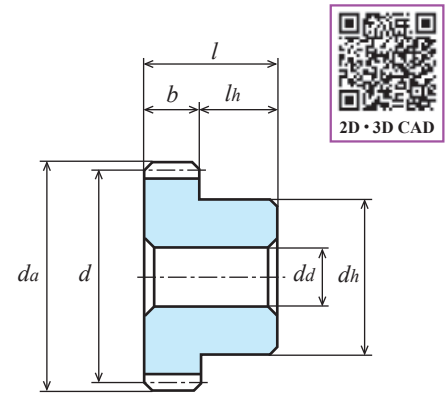

B1 type [-]

Unit: mm

Accuracy Class	Material	Pressure angle	Heat treatment	Tooth surface hardness	Backlash ①
[JIS B 1702-1] N9	SUS304	20°	—	—	0.12 to 0.24

★ No surface treatment is applied.

★ This allowable transfer capability table was prepared by using the formulas presented by the JGMA (Japan Gear Manufacturers Association).

For the unit conversion method, refer to P. 20 in "References."

① This is a theoretical value obtained when a pair of gears of the same type and material are meshed with each other.

Catalogue number	Number of teeth <i>z</i>	Reference diameter <i>d</i>	Tip diameter <i>da</i>	Type	Face width <i>b</i>	Hole diameter <i>da</i> (H8)	Hub diameter <i>dh</i>	Hub length <i>lh</i>	Overall length <i>l</i>	Weight <i>W</i> (g)
<b>S2SU 15B – 1410N</b>	15	φ 30	φ 34	B1	14	φ10	φ22	10	24	93.7
<b>S2SU 20B – 1412N</b>	20	φ 40	φ 44	B1	14	φ12	φ30	10	24	174.0
<b>S2SU 30B – 1414N</b>	30	φ 60	φ 64	B1	14	φ14	φ40	10	24	384.3
<b>S2SU 32B – 1214N</b>	32	φ 64	φ 68	B1	12	φ14	φ45	10	22	405.4
<b>S2SU 40B – 1214N</b>	40	φ 80	φ 84	B1	12	φ14	φ50	10	22	607.2
<b>S2SU 45B – 1214N</b>	45	φ 90	φ 94	B1	12	φ14	φ60	10	22	802.7
<b>S2SU 50B – 1215N</b>	50	φ100	φ104	B1	12	φ15	φ60	10	22	0.94(kg)
<b>S2SU 55B – 1215N</b>	55	φ110	φ114	B1	12	φ15	φ60	10	22	1.10(kg)
<b>S2SU 60B – 1215N</b>	60	φ120	φ124	B1	12	φ15	φ60	10	22	1.27(kg)

Catalogue number	Allowable transfer capability table for different revolutions per minute, Bending strength, (Unit: kW)						
	10rpm	100rpm	200rpm	400rpm	800rpm	1,200rpm	1,500rpm
<b>S2SU 15B – 1410N</b>	0.014	0.139	0.278	0.556	1.070	1.471	1.731
<b>S2SU 20B – 1412N</b>	0.022	0.218	0.435	0.870	1.580	2.128	2.497
<b>S2SU 30B – 1414N</b>	0.039	0.386	0.773	1.488	2.519	3.463	4.182
<b>S2SU 32B – 1214N</b>	0.036	0.361	0.722	1.374	2.307	3.207	3.866
<b>S2SU 40B – 1214N</b>	0.048	0.483	0.966	1.754	2.933	4.138	5.023
<b>S2SU 45B – 1214N</b>	0.056	0.560	1.121	1.979	3.349	4.729	5.722
<b>S2SU 50B – 1215N</b>	0.063	0.64	1.27	2.19	3.76	5.31	6.41
<b>S2SU 55B – 1215N</b>	0.071	0.72	1.40	2.40	4.16	5.88	7.17
<b>S2SU 60B – 1215N</b>	0.079	0.80	1.53	2.60	4.55	6.44	7.97

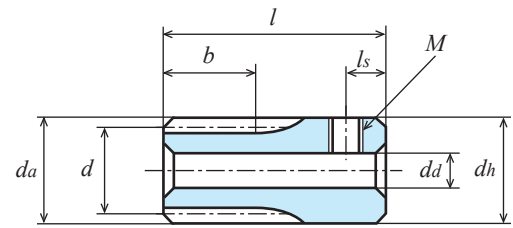
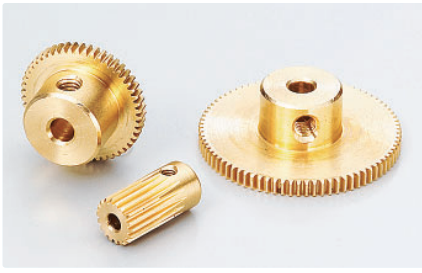

K2 type [+]

Unit: mm

Accuracy Class	Material	Pressure angle	Heat treatment	Tooth surface hardness	Backlash ①
[JIS B 1702-1] N9	C3604B	20°	—	—	0.02 to 0.06

★ No surface treatment is applied. Gears with a [+] are provided with one screw holes. No set screws are provided.

★ This allowable transfer capability table was prepared by using the formulas presented by the JGMA (Japan Gear Manufacturers Association).

For the unit conversion method, refer to P. 20 in "References."

① This is a theoretical value obtained when a pair of gears of the same type and material are meshed with each other.

Catalogue number	Number of teeth $z$	Refer-ence diameter $d$	Tip diameter $d_a$	Type	Face width $b$	Hole diameter $d_a(H8)$	Hub diameter $d_h$	Hub length $l_h$	Overall length $l$	Screw		Weight $W(g)$
										$M$	$l_s$	
S30B 14K + 0402	14	$\phi$ 4.2	$\phi$ 4.8	K2	4	$\phi$ 2	$\phi$ 5	8	12	M1.6	2.5	1.5
S30B 15K + 0402	15	$\phi$ 4.5	$\phi$ 5.1	K2	4	$\phi$ 2	$\phi$ 5.5	8	12	M1.6	2.5	1.8
S30B 16K + 0402	16	$\phi$ 4.8	$\phi$ 5.4	K2	4	$\phi$ 2	$\phi$ 5.5	8	12	M1.6	2.5	1.9
S30B 18K + 0402	18	$\phi$ 5.4	$\phi$ 6	K2	4	$\phi$ 2	$\phi$ 6	8	12	M2	2.5	2.3
S30B 20B + 0302	20	$\phi$ 6	$\phi$ 6.6	B1	3.2	$\phi$ 2	$\phi$ 5	4.8	8	M1.6	2.5	1.3
S30B 24B + 0302	24	$\phi$ 7.2	$\phi$ 7.8	B1	3.2	$\phi$ 2	$\phi$ 6	4.8	8	M2	2.5	2.0
S30B 25B + 0302	25	$\phi$ 7.5	$\phi$ 8.1	B1	3.2	$\phi$ 2	$\phi$ 6	4.8	8	M2	2.5	2.1
S30B 28B + 0302	28	$\phi$ 8.4	$\phi$ 9	B1	3.2	$\phi$ 2	$\phi$ 7	4.8	8	M2	2.5	2.8
S30B 30B + 0302	30	$\phi$ 9	$\phi$ 9.6	B1	3.2	$\phi$ 2	$\phi$ 8	4.8	8	M2	2.5	3.5
S30B 32B + 0202	32	$\phi$ 9.6	$\phi$ 10.2	B1	2	$\phi$ 2	$\phi$ 8	6	8	M2	3	3.5
S30B 35B + 0202	35	$\phi$ 10.5	$\phi$ 11.1	B1	2	$\phi$ 2	$\phi$ 8	6	8	M2	3	3.8
S30B 36B + 0203	36	$\phi$ 10.8	$\phi$ 11.4	B1	2	$\phi$ 3	$\phi$ 9	6	8	M3	3	4.2
S30B 40B + 0203	40	$\phi$ 12	$\phi$ 12.6	B1	2	$\phi$ 3	$\phi$ 10	6	8	M3	3	5.3
S30B 45B + 0203	45	$\phi$ 13.5	$\phi$ 14.1	B1	2	$\phi$ 3	$\phi$ 10	6	8	M3	3	5.8
S30B 48B + 0203	48	$\phi$ 14.4	$\phi$ 15	B1	2	$\phi$ 3	$\phi$ 10	6	8	M3	3	6.1
S30B 50B + 0203	50	$\phi$ 15	$\phi$ 15.6	B1	2	$\phi$ 3	$\phi$ 10	6	8	M3	3	6.4
S30B 56B + 0203	56	$\phi$ 16.8	$\phi$ 17.4	B1	2	$\phi$ 3	$\phi$ 10	6	8	M3	3	7.1
S30B 60B + 0203	60	$\phi$ 18	$\phi$ 18.6	B1	2	$\phi$ 3	$\phi$ 10	6	8	M3	3	7.7
S30B 64B + 0203	64	$\phi$ 19.2	$\phi$ 19.8	B1	2	$\phi$ 3	$\phi$ 10	6	8	M3	3	8.3
S30B 70B + 0203	70	$\phi$ 21	$\phi$ 21.6	B1	2	$\phi$ 3	$\phi$ 10	6	8	M3	3	9.3
S30B 72B + 0203	72	$\phi$ 21.6	$\phi$ 22.2	B1	2	$\phi$ 3	$\phi$ 10	6	8	M3	3	9.6
S30B 75B + 0203	75	$\phi$ 22.5	$\phi$ 23.1	B1	2	$\phi$ 3	$\phi$ 10	6	8	M3	3	10.1
S30B 80B + 0203	80	$\phi$ 24	$\phi$ 24.6	B1	2	$\phi$ 3	$\phi$ 10	6	8	M3	3	11.1
S30B 90B + 0203	90	$\phi$ 27	$\phi$ 27.6	B1	2	$\phi$ 3	$\phi$ 10	6	8	M3	3	13.1
S30B 96B + 0203	96	$\phi$ 28.8	$\phi$ 29.4	B1	2	$\phi$ 3	$\phi$ 10	6	8	M3	3	14.4
S30B 100B + 0203	100	$\phi$ 30	$\phi$ 30.6	B1	2	$\phi$ 3	$\phi$ 10	6	8	M3	3	15.4
S30B 108B + 0203	108	$\phi$ 32.4	$\phi$ 33	B1	2	$\phi$ 3	$\phi$ 10	6	8	M3	3	17.4
S30B 120B + 0203	120	$\phi$ 36	$\phi$ 36.6	B1	2	$\phi$ 3	$\phi$ 10	6	8	M3	3	20.7



2D • 3D CAD

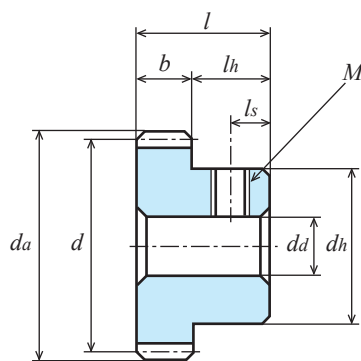

B1 type [+]

Catalogue number	Allowable transfer capability table for different revolutions per minute, Bending strength, (Unit: W)						
	10rpm	100rpm	200rpm	400rpm	800rpm	1,200rpm	1,500rpm
<b>S30B 14K + 0402</b>	0.03	0.32	0.64	1.27	2.55	3.82	4.78
<b>S30B 15K + 0402</b>	0.04	0.36	0.71	1.43	2.86	4.29	5.36
<b>S30B 16K + 0402</b>	0.04	0.40	0.79	1.59	3.17	4.76	5.95
<b>S30B 18K + 0402</b>	0.05	0.48	0.95	1.91	3.81	5.72	7.15
<b>S30B 20B + 0302</b>	0.04	0.45	0.90	1.79	3.58	5.37	6.71
<b>S30B 24B + 0302</b>	0.06	0.58	1.17	2.33	4.67	7.00	8.75
<b>S30B 25B + 0302</b>	0.06	0.62	1.24	2.47	4.95	7.42	9.27
<b>S30B 28B + 0302</b>	0.07	0.72	1.45	2.89	5.79	8.68	10.86
<b>S30B 30B + 0302</b>	0.08	0.79	1.59	3.18	6.36	9.54	11.92
<b>S30B 32B + 0202</b>	0.05	0.54	1.08	2.17	4.33	6.50	8.12
<b>S30B 35B + 0202</b>	0.06	0.61	1.22	2.44	4.88	7.32	9.15
<b>S30B 36B + 0203</b>	0.06	0.63	1.27	2.53	5.06	7.59	9.49
<b>S30B 40B + 0203</b>	0.07	0.72	1.45	2.90	5.80	8.70	10.87
<b>S30B 45B + 0203</b>	0.08	0.84	1.68	3.36	6.72	10.09	12.49
<b>S30B 48B + 0203</b>	0.09	0.91	1.82	3.64	7.29	10.93	13.40
<b>S30B 50B + 0203</b>	0.10	0.96	1.92	3.83	7.66	11.49	13.99
<b>S30B 56B + 0203</b>	0.11	1.10	2.20	4.40	8.80	13.09	15.74
<b>S30B 60B + 0203</b>	0.12	1.20	2.39	4.78	9.56	14.07	16.88
<b>S30B 64B + 0203</b>	0.13	1.29	2.58	5.16	10.33	15.02	17.99
<b>S30B 70B + 0203</b>	0.14	1.43	2.87	5.74	11.48	16.43	19.61
<b>S30B 72B + 0203</b>	0.15	1.48	2.97	5.93	11.87	16.89	20.14
<b>S30B 75B + 0203</b>	0.16	1.56	3.11	6.22	12.44	17.58	20.92
<b>S30B 80B + 0203</b>	0.17	1.68	3.35	6.71	13.40	18.69	22.20
<b>S30B 90B + 0203</b>	0.19	1.92	3.83	7.67	15.04	20.83	24.62
<b>S30B 96B + 0203</b>	0.21	2.06	4.13	8.25	16.01	22.07	26.02
<b>S30B 100B + 0203</b>	0.22	2.16	4.32	8.64	16.64	22.89	26.93
<b>S30B 108B + 0203</b>	0.24	2.36	4.71	9.42	17.88	24.46	28.68
<b>S30B 120B + 0203</b>	0.26	2.65	5.30	10.60	19.69	26.73	31.19

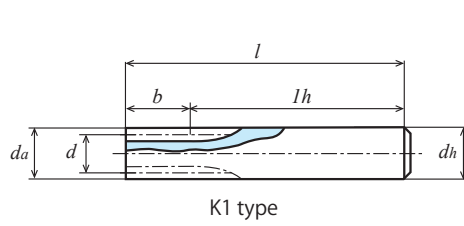

K1 type

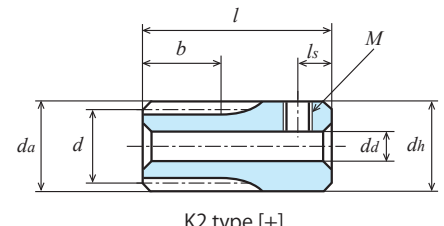

K2 type [+]

Unit: mm

Accuracy Class ②	Material	Pressure angle	Heat treatment	Tooth surface hardness	Backlash ①
[JIS B 1702-1] N9/ Outside of control range	C3713P, C3604B	20°	—	—	0.02 to 0.06

★ No surface treatment is applied. Gears with a [+] are provided with one screw holes. No set screws are provided.

★ This allowable transfer capability table was prepared by using the formulas presented by the JGMA (Japan Gear Manufacturers Association). For the unit conversion method, refer to P. 20 in "References."

① This is a theoretical value obtained when a pair of gears of the same type and material are meshed with each other.

② B1, K1, and K2 type: JIS Class N9 / A1 and B2: Outside of accuracy control range

③ The tolerance of the hole diameter dd of the A1 type is 0 to +0.1 mm.

Catalogue number	Number of teeth <i>z</i>	Refer- ence diameter <i>d</i>	Tip diameter <i>da</i>	Type	Face width <i>b</i>	Hole diameter ③ <i>da(H8)</i>	Hub diameter <i>dh</i>	Hub length <i>lh</i>	Overall length <i>l</i>	Screw		Weight <i>W(g)</i>
										<i>M</i>	<i>ls</i>	
S50B 10K — 1006	10	φ 5	φ 6	K1	10	-	φ 6	45	55	-	-	12.5
S50B 12K — 1007	12	φ 6	φ 7	K1	10	-	φ 7	45	55	-	-	17.1
S50B 14K — 1008	14	φ 7	φ 8	K1	10	-	φ 8	45	55	-	-	22.5
S50B 15K + 0803	15	φ 7.5	φ 8.5	K2	8	φ 3	φ 9	10	18	M3	3	7.2
S50B 16K + 0803	16	φ 8	φ 9	K2	8	φ 3	φ 9	10	18	M3	3	7.6
S50B 18K + 0803	18	φ 9	φ 10	K2	8	φ 3	φ 10	10	18	M3	3	9.7
S50B 20K + 0803	20	φ 10	φ 11	K2	8	φ 3	φ 11	10	18	M3	3	12.2
S50B 20B + 0303	20	φ 10	φ 11	B1	3	φ 3	φ 8.2	5	8	M3	2.5	3.8
S50B 24B + 0303	24	φ 12	φ 13	B1	3	φ 3	φ 10	5	8	M3	2.5	5.6
S50B 25B + 0303	25	φ 12.5	φ 13.5	B1	3	φ 3	φ 10	5	8	M3	2.5	5.8
S50B 26B + 0303	26	φ 13	φ 14	B1	3	φ 3	φ 10	5	8	M3	2.5	6.1
S50B 28B + 0303	28	φ 14	φ 15	B1	3	φ 3	φ 10	5	8	M3	2.5	6.6
S50B 30B + 0303	30	φ 15	φ 16	B1	3	φ 3	φ 10	5	8	M3	2.5	7.2
S50B 32B + 0303	32	φ 16	φ 17	B1	3	φ 3	φ 10	5	8	M3	2.5	7.8
S50B 35B + 0303	35	φ 17.5	φ 18.5	B1	3	φ 3	φ 10	5	8	M3	2.5	8.8
S50B 36B + 0303	36	φ 18	φ 19	B1	3	φ 3	φ 10	5	8	M3	2.5	9.2
S50B 40A — 0208	40	φ 20	φ 21	A1	2	φ 8	-	-	2	-	-	4.5
S50B 40B + 0203	40	φ 20	φ 21	B2	2	φ 3	φ 10	5	7.5	M3	2.5	8.1
S50B 42A — 0208	42	φ 21	φ 22	A1	2	φ 8	-	-	2	-	-	5.0
S50B 42B + 0203	42	φ 21	φ 22	B2	2	φ 3	φ 10	5	7.5	M3	2.5	8.6
S50B 45A — 0208	45	φ 22.5	φ 23.5	A1	2	φ 8	-	-	2	-	-	5.9
S50B 45B + 0203	45	φ 22.5	φ 23.5	B2	2	φ 3	φ 10	5	7.5	M3	2.5	9.5
S50B 48A — 0208	48	φ 24	φ 25	A1	2	φ 8	-	-	2	-	-	6.8
S50B 48B + 0203	48	φ 24	φ 25	B2	2	φ 3	φ 10	5	7.5	M3	2.5	10.4
S50B 50A — 0208	50	φ 25	φ 26	A1	2	φ 8	-	-	2	-	-	7.5
S50B 50B + 0203	50	φ 25	φ 26	B2	2	φ 3	φ 10	5	7.5	M3	2.5	11.1
S50B 55A — 0208	55	φ 27.5	φ 28.5	A1	2	φ 8	-	-	2	-	-	9.2
S50B 55B + 0203	55	φ 27.5	φ 28.5	B2	2	φ 3	φ 10	5	7.5	M3	2.5	12.8
S50B 56A — 0208	56	φ 28	φ 29	A1	2	φ 8	-	-	2	-	-	9.6
S50B 56B + 0203	56	φ 28	φ 29	B2	2	φ 3	φ 10	5	7.5	M3	2.5	13.2
S50B 58A — 0208	58	φ 29	φ 30	A1	2	φ 8	-	-	2	-	-	10.4
S50B 58B + 0203	58	φ 29	φ 30	B2	2	φ 3	φ 10	5	7.5	M3	2.5	14.0
S50B 60A — 0208	60	φ 30	φ 31	A1	2	φ 8	-	-	2	-	-	11.2
S50B 60B + 0203	60	φ 30	φ 31	B2	2	φ 3	φ 10	5	7.5	M3	2.5	14.8
S50B 64A — 0208	64	φ 32	φ 33	A1	2	φ 8	-	-	2	-	-	12.8
S50B 64B + 0203	64	φ 32	φ 33	B2	2	φ 3	φ 10	5	7.5	M3	2.5	16.4
S50B 65A — 0208	65	φ 32.5	φ 33.5	A1	2	φ 8	-	-	2	-	-	12.3
S50B 65B + 0203	65	φ 32.5	φ 33.5	B2	2	φ 3	φ 10	5	7.5	M3	2.5	16.8
S50B 68A — 0208	68	φ 34	φ 35	A1	2	φ 8	-	-	2	-	-	14.6
S50B 68B + 0203	68	φ 34	φ 35	B2	2	φ 3	φ 10	5	7.5	M3	2.5	18.2
S50B 70A — 0208	70	φ 35	φ 36	A1	2	φ 8	-	-	2	-	-	15.5
S50B 70B + 0203	70	φ 35	φ 36	B2	2	φ 3	φ 10	5	7.5	M3	2.5	19.1



2D • 3D CAD

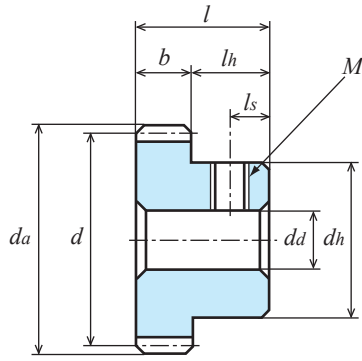

B1 type [+]

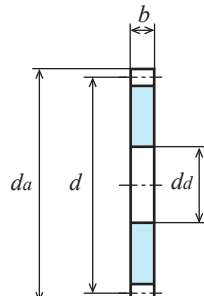

A1 type

$db$  is the same size as  $dd$  with the same number of teeth of the A1 type.

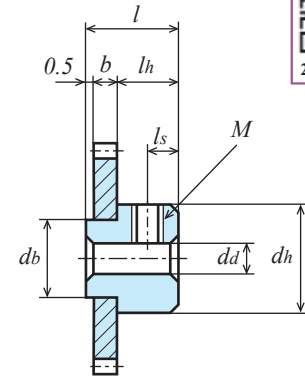

B2 type (Hub caulking)

Catalogue number	Number of teeth $z$	Reference diameter $d$	Tip diameter $d_a$	Type	Face width $b$	Hole diameter $\phi$ $d_d$ (H8)	Hub diameter $\phi$ $d_h$	Hub length $l_h$	Overall length $l$	Screw		Weight $W(g)$
										$M$	$l_s$	
S50B 72A – 0208	72	$\phi 36$	$\phi 37$	A1	2	$\phi 8$	-	-	2	-	-	16.5
S50B 72B + 0203	72	$\phi 36$	$\phi 37$	B2	2	$\phi 3$	$\phi 10$	5	7.5	M3	2.5	20.0
S50B 75A – 0208	75	$\phi 37.5$	$\phi 38.5$	A1	2	$\phi 8$	-	-	2	-	-	17.9
S50B 75B + 0203	75	$\phi 37.5$	$\phi 38.5$	B2	2	$\phi 3$	$\phi 10$	5	7.5	M3	2.5	21.5
S50B 80A – 0208	80	$\phi 40$	$\phi 41$	A1	2	$\phi 8$	-	-	2	-	-	20.5
S50B 80B + 0203	80	$\phi 40$	$\phi 41$	B2	2	$\phi 3$	$\phi 10$	5	7.5	M3	2.5	24.1
S50B 84A – 0208	84	$\phi 42$	$\phi 43$	A1	2	$\phi 8$	-	-	2	-	-	22.7
S50B 84B + 0203	84	$\phi 42$	$\phi 43$	B2	2	$\phi 3$	$\phi 10$	5	7.5	M3	2.5	26.3

Catalogue number	Allowable transfer capability table for different revolutions per minute, Bending strength, (Unit: W)						
	10rpm	100rpm	200rpm	400rpm	800rpm	1,200rpm	1,500rpm
S50B 10K – 1006	0.12	1.21	2.42	4.85	9.70	14.55	18.18
S50B 12K – 1007	0.17	1.70	3.40	6.79	13.58	20.37	25.47
S50B 14K – 1008	0.22	2.21	4.43	8.85	17.71	26.56	33.20
S50B 15K + 0803	0.20	1.98	3.97	7.94	15.87	23.81	29.76
S50B 16K + 0803	0.22	2.20	4.40	8.81	17.62	26.42	33.03
S50B 18K + 0803	0.26	2.65	5.29	10.59	21.18	31.76	39.71
S50B 20K + 0803	0.31	3.11	6.22	12.43	24.86	37.30	46.62
S50B 20B + 0303	0.12	1.17	2.33	4.66	9.32	13.99	17.48
S50B 24B + 0303	0.15	1.52	3.04	6.08	12.16	18.23	22.79
S50B 25B + 0303	0.16	1.61	3.22	6.44	12.88	19.32	24.15
S50B 26B + 0303	0.17	1.70	3.40	6.80	13.61	20.41	25.43
S50B 28B + 0303	0.19	1.88	3.77	7.54	15.08	22.62	27.85
S50B 30B + 0303	0.21	2.07	4.14	8.28	16.56	24.83	30.23
S50B 32B + 0303	0.23	2.26	4.51	9.03	18.05	27.06	32.60
S50B 35B + 0303	0.25	2.54	5.08	10.16	20.32	30.04	36.08
S50B 36B + 0303	0.26	2.64	5.27	10.54	21.08	31.02	37.22
S50B 40A – 0208	0.20	2.01	4.03	8.05	16.10	23.26	27.81
S50B 42A – 0208	0.21	2.14	4.28	8.57	17.13	24.53	29.28
S50B 45A – 0208	0.23	2.33	4.67	9.34	18.68	26.38	31.41
S50B 48A – 0208	0.25	2.53	5.06	10.12	20.22	28.21	33.50
S50B 50A – 0208	0.27	2.66	5.32	10.64	21.14	29.41	34.87
S50B 55A – 0208	0.30	2.99	5.98	11.96	23.38	32.34	38.19
S50B 56A – 0208	0.31	3.06	6.11	12.22	23.82	32.91	38.84
S50B 58A – 0208	0.32	3.19	6.37	12.75	24.70	34.05	40.12
S50B 60A – 0208	0.33	3.32	6.64	13.28	25.57	35.17	41.38
S50B 64A – 0208	0.36	3.59	7.17	14.34	27.29	37.36	43.83
S50B 65A – 0208	0.37	3.65	7.30	14.61	27.72	37.90	44.43
S50B 68A – 0208	0.39	3.85	7.70	15.41	28.97	39.50	46.21
S50B 70A – 0208	0.40	3.99	7.97	15.94	29.80	40.54	47.36
S50B 72A – 0208	0.41	4.12	8.24	16.48	30.62	41.57	48.50
S50B 75A – 0208	0.43	4.32	8.64	17.28	31.84	43.09	50.17
S50B 80A – 0208	0.47	4.66	9.31	18.63	33.83	45.55	53.44
S50B 84A – 0208	0.49	4.92	9.84	19.68	35.34	47.40	56.14

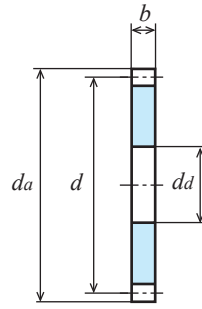
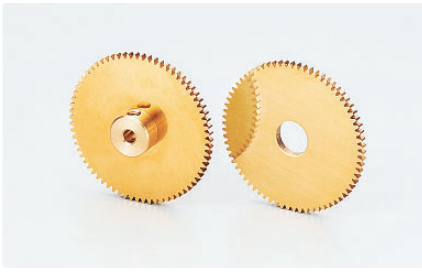

A1 type

$db$  is the same size as  $dd$  with the same number of teeth of the A1 type.

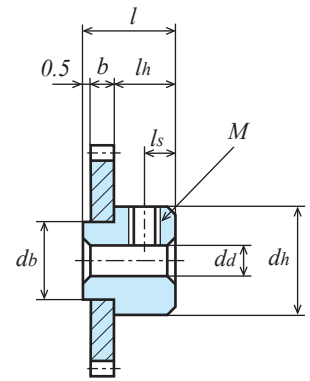

B2 type (Hub caulking)

Unit: mm

Accuracy Class ②	Material	Pressure angle	Heat treatment	Tooth surface hardness	Backlash ①
Outside of control range	C3713P, C3604B	20°	—	—	0.02 to 0.06

★ No surface treatment is applied. Gears with a [+] are provided with one screw holes. No set screws are provided.

★ This allowable transfer capability table was prepared by using the formulas presented by the JGMA (Japan Gear Manufacturers Association). For the unit conversion method, refer to P. 20 in "References."

① This is a theoretical value obtained when a pair of gears of the same type and material are meshed with each other. ② A1 and B2: Outside of accuracy control range

③ The tolerance of the hole diameter  $dd$  of the A1 type is 0 to +0.1 mm.

Catalogue number	Number of teeth $z$	Reference diameter $d$	Tip diameter $da$	Type	Face width $b$	Hole diameter $dd$ <sup>③</sup>	Hub diameter $dh$	Hub length $lh$	Overall length $l$	Screw		Weight $W(g)$
										$M$	$ls$	
S50B 85A - 0208	85	$\phi 42.5$	$\phi 43.5$	A1	2	$\phi 8$	-	-	2	-	-	23.3
S50B 85B + 0203	85	$\phi 42.5$	$\phi 43.5$	B2	2	$\phi 3$	$\phi 10$	5	7.5	M3	2.5	26.9
S50B 90A - 0208	90	$\phi 45$	$\phi 46$	A1	2	$\phi 8$	-	-	2	-	-	26.2
S50B 90B + 0203	90	$\phi 45$	$\phi 46$	B2	2	$\phi 3$	$\phi 10$	5	7.5	M3	2.5	29.8
S50B 95A - 0208	95	$\phi 47.5$	$\phi 48.5$	A1	2	$\phi 8$	-	-	2	-	-	29.3
S50B 95B + 0203	95	$\phi 47.5$	$\phi 48.5$	B2	2	$\phi 3$	$\phi 10$	5	7.5	M3	2.5	32.9
S50B 100A - 0212	100	$\phi 50$	$\phi 51$	A1	2	$\phi 12$	-	-	2	-	-	32.5
S50B 100B + 0203	100	$\phi 50$	$\phi 51$	B2	2	$\phi 3$	$\phi 15$	7	9.5	M3	3.5	36.1
S50B 105A - 0212	105	$\phi 52.5$	$\phi 53.5$	A1	2	$\phi 12$	-	-	2	-	-	36.0
S50B 105B + 0203	105	$\phi 52.5$	$\phi 53.5$	B2	2	$\phi 3$	$\phi 15$	7	9.5	M3	3.5	39.5
S50B 110A - 0212	110	$\phi 55$	$\phi 56$	A1	2	$\phi 12$	-	-	2	-	-	39.5
S50B 110B + 0203	110	$\phi 55$	$\phi 56$	B2	2	$\phi 3$	$\phi 15$	7	9.5	M3	3.5	43.1

Catalogue number	Allowable transfer capability table for different revolutions per minute, Bending strength, (Unit: W)						
	10rpm	100rpm	200rpm	400rpm	800rpm	1,200rpm	1,500rpm
S50B 85A - 0208	0.50	4.99	9.98	19.95	35.72	47.87	56.82
S50B 90A - 0208	0.53	5.33	10.65	21.30	37.61	50.15	60.21
S50B 95A - 0208	0.57	5.66	11.33	22.65	39.44	52.36	63.55
S50B 100A - 0212	0.60	6.00	12.00	23.83	41.24	55.09	66.86
S50B 105A - 0212	0.63	6.34	12.68	24.98	42.98	57.85	70.12
S50B 110A - 0212	0.67	6.68	13.36	26.12	44.69	60.59	73.34

CONTENTS

INFORMATION

GEARBOXES

ANTI-BACKLASH  
SPUR GEARS

**SPUR GEARS**

RACKS

HELICAL GEARS AND  
SCREW GEARS

MITER GEARS

BEVEL GEARS

WORMS AND WORM  
WHEELS

REFERENCES



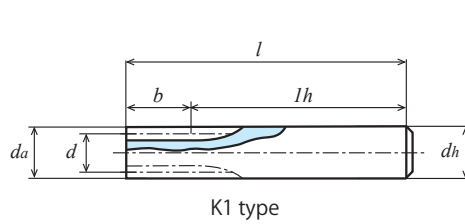

K1 type

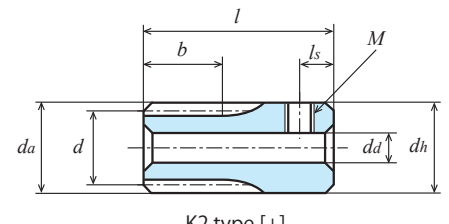

K2 type [+]

Unit: mm

Accuracy Class ②	Material	Pressure angle	Heat treatment	Tooth surface hardness	Backlash ①
[JIS B 1702-1] N9 / Outside of control range	C3713P, C3604B	20°	—	—	0.02 to 0.06

★ No surface treatment is applied. Gears with a [+] are provided with one screw hole and set screw.

★ This allowable transfer capability table was prepared by using the formulas presented by the JGMA (Japan Gear Manufacturers Association). For the unit conversion method, refer to P. 20 in "References."

① This is a theoretical value obtained when a pair of gears of the same type and material are meshed with each other.

② B1, K1, and K2 type: JIS Class N9 / A1 and B2: Outside of accuracy control range

③ The tolerance of the hole diameter dd of the A1 type is 0 to +0.1 mm.

Catalogue number	Number of teeth <i>z</i>	Refer-ence diameter <i>d</i>	Tip diameter <i>da</i>	Type	Face width <i>b</i>	Hole diameter ③ <i>da(H8)</i>	Hub diameter <i>dh</i>	Hub length <i>lh</i>	Overall length <i>l</i>	Screw		Weight <i>W(g)</i>
										<i>M</i>	<i>ls</i>	
S75B 10K — 0809	10	φ 7.5	φ 9	K1	8	-	φ 9	47	55	-	-	28.4
S75B 12K — 0811	12	φ 9	φ 10.5	K1	8	-	φ 11	47	55	-	-	42.3
S75B 14K + 0805	14	φ 10.5	φ 12	K2	8	φ 5	φ 12	12	20	M3	3	13.9
S75B 15K + 0805	15	φ 11.25	φ 12.75	K2	8	φ 5	φ 12.75	12	20	M3	3	16.3
S75B 16K + 0805	16	φ 12	φ 13.5	K2	8	φ 5	φ 13.5	12	20	M3	3	18.8
S75B 16B + 0305	16	φ 12	φ 13.5	B1	3	φ 5	φ 10	7	10	M3	3.5	5.8
S75B 18B + 0305	18	φ 13.5	φ 15	B1	3	φ 5	φ 11	7	10	M3	3.5	7.5
S75B 20K + 0805	20	φ 15	φ 16.5	K2	8	φ 5	φ 16.5	12	20	M3	3	30.2
S75B 20B + 0306	20	φ 15	φ 16.5	B1	3	φ 6	φ 12	7	10	M4	3.5	8.6
S75B 24B + 0306	24	φ 18	φ 19.5	B1	3	φ 6	φ 14	7	10	M4	3.5	11.7
S75B 25B + 0306	25	φ 18.75	φ 20.25	B1	3	φ 6	φ 14	7	10	M4	3.5	12.3
S75B 26B + 0306	26	φ 19.5	φ 21	B1	3	φ 6	φ 14	7	10	M4	3.5	12.9
S75B 28B + 0306	28	φ 21	φ 22.5	B1	3	φ 6	φ 14	7	10	M4	3.5	14.1
S75B 30B + 0306	30	φ 22.5	φ 24	B1	3	φ 6	φ 15	7	10	M4	3.5	16.7
S75B 32B + 0306	32	φ 24	φ 25.5	B1	3	φ 6	φ 15	7	10	M4	3.5	18.1
S75B 35B + 0306	35	φ 26.25	φ 27.75	B1	3	φ 6	φ 18	7	10	M4	3.5	24.9
S75B 36B + 0306	36	φ 27	φ 28.5	B1	3	φ 6	φ 18	7	10	M4	3.5	25.7
S75B 40B + 0306	40	φ 30	φ 31.5	B1	3	φ 6	φ 20	7	10	M4	3.5	33.8
S75B 42B + 0306	42	φ 31.5	φ 33	B1	3	φ 6	φ 20	7	10	M4	3.5	35.6
S75B 45B + 0306	45	φ 33.75	φ 35.25	B1	3	φ 6	φ 20	7	10	M4	3.5	38.6
S75B 48B + 0306	48	φ 36	φ 37.5	B1	3	φ 6	φ 20	7	10	M4	3.5	41.7
S75B 50A — 0315	50	φ 37.5	φ 39	A1	3	φ 15	-	-	3	-	-	23.7
S75B 50B + 0306	50	φ 37.5	φ 39	B2	3	φ 6	φ 20	7	10.5	M4	3.5	43.8
S75B 55A — 0315	55	φ 41.25	φ 42.75	A1	3	φ 15	-	-	3	-	-	29.6
S75B 55B + 0306	55	φ 41.25	φ 42.75	B2	3	φ 6	φ 20	7	10.5	M4	3.5	49.7
S75B 56A — 0315	56	φ 42	φ 43.5	A1	3	φ 15	-	-	3	-	-	30.8
S75B 56B + 0306	56	φ 42	φ 43.5	B2	3	φ 6	φ 20	7	10.5	M4	3.5	50.9
S75B 58A — 0315	58	φ 43.5	φ 45	A1	3	φ 15	-	-	3	-	-	33.4
S75B 58B + 0306	58	φ 43.5	φ 45	B2	3	φ 6	φ 20	7	10.5	M4	3.5	53.5
S75B 60A — 0315	60	φ 45	φ 46.5	A1	3	φ 15	-	-	3	-	-	36.1
S75B 60B + 0306	60	φ 45	φ 46.5	B2	3	φ 6	φ 20	7	10.5	M4	3.5	56.2
S75B 62A — 0315	62	φ 46.5	φ 48	A1	3	φ 15	-	-	3	-	-	38.8
S75B 62B + 0306	62	φ 46.5	φ 48	B2	3	φ 6	φ 20	7	10.5	M4	3.5	58.9
S75B 64A — 0315	64	φ 48	φ 49.5	A1	3	φ 15	-	-	3	-	-	41.6
S75B 64B + 0306	64	φ 48	φ 49.5	B2	3	φ 6	φ 20	7	10.5	M4	3.5	61.8
S75B 66A — 0315	66	φ 49.5	φ 51	A1	3	φ 15	-	-	3	-	-	44.6
S75B 66B + 0306	66	φ 49.5	φ 51	B2	3	φ 6	φ 20	7	10.5	M4	3.5	64.7
S75B 68A — 0315	68	φ 51	φ 52.5	A1	3	φ 15	-	-	3	-	-	47.6
S75B 68B + 0306	68	φ 51	φ 52.5	B2	3	φ 6	φ 20	7	10.5	M4	3.5	67.7
S75B 70A — 0315	70	φ 52.5	φ 54	A1	3	φ 15	-	-	3	-	-	50.7
S75B 70B + 0306	70	φ 52.5	φ 54	B2	3	φ 6	φ 20	7	10.5	M4	3.5	70.8



2D • 3D CAD

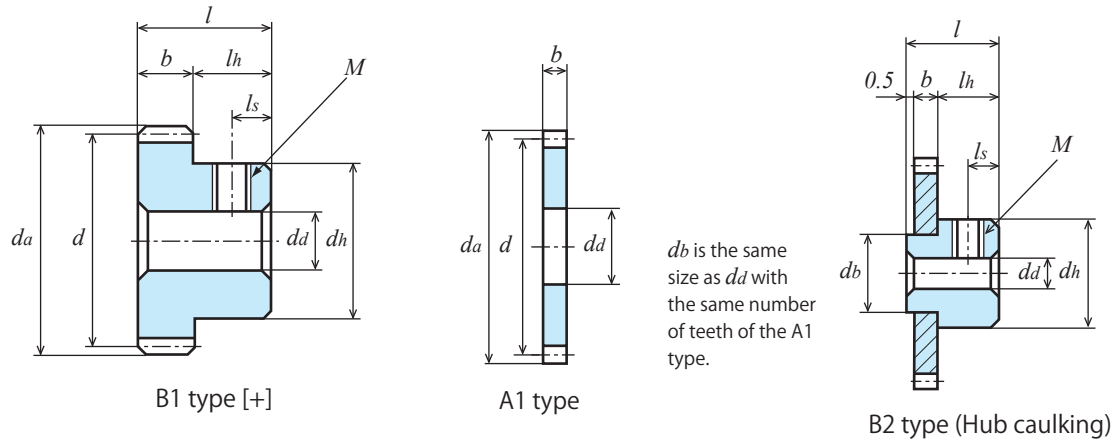

Catalogue number	Number of teeth $z$	Reference diameter $d$	Tip diameter $d_a$	Type	Face width $b$	Hole diameter $d_a$ (H8)	Hub diameter $d_h$	Hub length $l_h$	Overall length $l$	Screw		Weight $W(g)$
										$M$	$l_s$	
<b>S75B 72A – 0315</b>	72	$\phi 54$	$\phi 55.5$	A1	3	$\phi 15$	-	-	3	-	-	53.9
<b>S75B 72B + 0306</b>	72	$\phi 54$	$\phi 55.5$	B2	3	$\phi 6$	$\phi 20$	7	10.5	M4	3.5	74.0
<b>S75B 75A – 0315</b>	75	$\phi 56.25$	$\phi 57.75$	A1	3	$\phi 15$	-	-	3	-	-	58.9
<b>S75B 75B + 0306</b>	75	$\phi 56.25$	$\phi 57.75$	B2	3	$\phi 6$	$\phi 20$	7	10.5	M4	3.5	79.0

Catalogue number	Allowable transfer capability table for different revolutions per minute, Bending strength, (Unit: W)						
	10rpm	100rpm	200rpm	400rpm	800rpm	1,200rpm	1,500rpm
<b>S75B 10K – 0809</b>	0.22	2.18	4.36	8.73	17.46	26.18	32.73
<b>S75B 12K – 0811</b>	0.31	3.06	6.11	12.22	24.45	36.67	45.84
<b>S75B 14K + 0805</b>	0.40	3.98	7.97	15.93	31.87	47.80	59.75
<b>S75B 15K + 0805</b>	0.45	4.46	8.93	17.86	35.72	53.57	66.97
<b>S75B 16K + 0805</b>	0.50	4.95	9.91	19.82	39.64	59.45	74.32
<b>S75B 16B + 0305</b>	0.19	1.86	3.72	7.43	14.86	22.30	27.87
<b>S75B 18B + 0305</b>	0.22	2.23	4.47	8.93	17.87	26.80	33.20
<b>S75B 20K + 0805</b>	0.70	6.99	13.99	27.97	55.94	83.92	102.17
<b>S75B 20B + 0306</b>	0.26	2.62	5.24	10.49	20.98	31.47	38.31
<b>S75B 24B + 0306</b>	0.34	3.42	6.84	13.67	27.35	40.23	48.28
<b>S75B 25B + 0306</b>	0.36	3.62	7.24	14.49	28.98	42.33	50.74
<b>S75B 26B + 0306</b>	0.38	3.83	7.65	15.31	30.62	44.42	53.17
<b>S75B 28B + 0306</b>	0.42	4.24	8.48	16.96	33.92	48.56	57.96
<b>S75B 30B + 0306</b>	0.47	4.66	9.31	18.62	37.25	52.61	62.64
<b>S75B 32B + 0306</b>	0.51	5.08	10.16	20.31	40.59	56.62	67.24
<b>S75B 35B + 0306</b>	0.57	5.72	11.43	22.86	45.05	62.50	73.96
<b>S75B 36B + 0306</b>	0.59	5.93	11.86	23.72	46.53	64.43	76.15
<b>S75B 40B + 0306</b>	0.68	6.79	13.59	27.17	52.33	71.97	84.68
<b>S75B 42B + 0306</b>	0.72	7.23	14.46	28.92	55.19	75.64	88.80
<b>S75B 45B + 0306</b>	0.79	7.88	15.76	31.52	59.35	80.95	94.74
<b>S75B 48B + 0306</b>	0.85	8.54	17.08	34.16	63.47	86.16	100.53
<b>S75B 50A – 0315</b>	0.90	8.98	17.96	35.92	66.17	89.54	104.28
<b>S75B 55A – 0315</b>	1.01	10.09	20.18	40.36	72.77	97.73	115.35
<b>S75B 56A – 0315</b>	1.03	10.31	20.62	41.25	74.06	99.32	117.63
<b>S75B 58A – 0315</b>	1.08	10.76	21.52	43.03	76.61	102.45	122.17
<b>S75B 60A – 0315</b>	1.12	11.20	22.41	44.82	79.13	105.53	126.68
<b>S75B 62A – 0315</b>	1.17	11.65	23.30	46.61	81.62	108.54	131.16
<b>S75B 64A – 0315</b>	1.21	12.10	24.20	48.37	84.07	111.64	135.62
<b>S75B 66A – 0315</b>	1.26	12.55	25.10	49.93	86.48	115.37	140.04
<b>S75B 68A – 0315</b>	1.30	13.00	26.00	51.48	88.86	119.08	144.43
<b>S75B 70A – 0315</b>	1.35	13.45	26.90	53.02	91.21	122.77	148.79
<b>S75B 72A – 0315</b>	1.39	13.90	27.81	54.55	93.53	126.44	153.12
<b>S75B 75A – 0315</b>	1.46	14.58	29.17	56.81	96.94	131.90	159.56

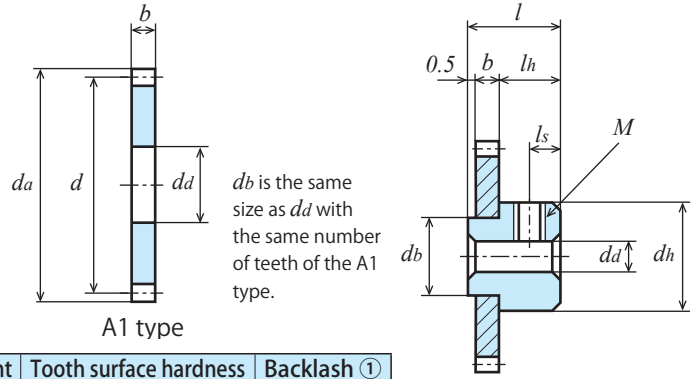
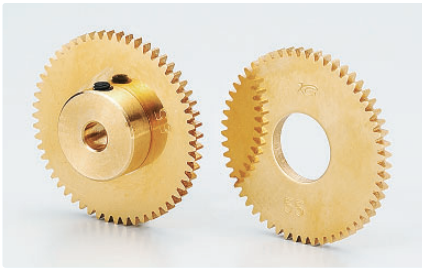

Unit: mm

Accuracy Class ②	Material	Pressure angle	Heat treatment	Tooth surface hardness	Backlash ①
Outside of control range	C3713P、C3604B	20°	—	—	0.02 to 0.06

B2 type (Hub caulking)

★ No surface treatment is applied. Gears with a [+] are provided with one screw hole and set screw.

★ This allowable transfer capability table was prepared by using the formulas presented by the JGMA (Japan Gear Manufacturers Association). For the unit conversion method, refer to P. 20 in "References."

① This is a theoretical value obtained when a pair of gears of the same type and material are meshed with each other. ② A1 and B2: Outside of accuracy control range

③ The tolerance of the hole diameter dd of the A1 type is 0 to +0.1 mm.

Catalogue number	Number of teeth <i>z</i>	Refer- ence diameter <i>d</i>	Tip diameter <i>da</i>	Type	Face width <i>b</i>	Hole diameter ③ <i>da(H8)</i>	Hub diameter <i>dh</i>	Hub length <i>lh</i>	Overall length <i>l</i>	Screw		Weight <i>W(g)</i>
										<i>M</i>	<i>ls</i>	
S75B 80A – 0315	80	φ60	φ61.5	A1	3	φ15	-	-	3	-	-	67.6
S75B 80B + 0306	80	φ60	φ61.5	B2	3	φ 6	φ20	7	10.5	M4	3.5	87.7
S75B 85A – 0315	85	φ63.75	φ65.25	A1	3	φ15	-	-	3	-	-	76.9
S75B 85B + 0306	85	φ63.75	φ65.25	B2	3	φ 6	φ20	7	10.5	M4	3.5	97.0
S75B 90A – 0315	90	φ67.5	φ69	A1	3	φ15	-	-	3	-	-	86.7
S75B 90B + 0306	90	φ67.5	φ69	B2	3	φ 6	φ20	7	10.5	M4	3.5	106.9
S75B 95A – 0315	95	φ71.25	φ72.75	A1	3	φ15	-	-	3	-	-	97.2
S75B 95B + 0306	95	φ71.25	φ72.75	B2	3	φ 6	φ20	7	10.5	M4	3.5	117.3
S75B 100A – 0315	100	φ75	φ76.5	A1	3	φ15	-	-	3	-	-	108.1
S75B 100B + 0306	100	φ75	φ76.5	B2	3	φ 6	φ20	7	10.5	M4	3.5	128.3
S75B 105A – 0315	105	φ78.75	φ80.25	A1	3	φ15	-	-	3	-	-	119.7
S75B 105B + 0306	105	φ78.75	φ80.25	B2	3	φ 6	φ20	7	10.5	M4	3.5	139.8
S75B 110A – 0315	110	φ82.5	φ84	A1	3	φ15	-	-	3	-	-	131.8
S75B 110B + 0306	110	φ82.5	φ84	B2	3	φ 6	φ20	7	10.5	M4	3.5	151.9
S75B 115A – 0315	115	φ86.25	φ87.75	A1	3	φ15	-	-	3	-	-	144.5
S75B 115B + 0306	115	φ86.25	φ87.75	B2	3	φ 6	φ20	7	10.5	M4	3.5	164.6
S75B 120A – 0315	120	φ90	φ91.5	A1	3	φ15	-	-	3	-	-	157.7
S75B 120B + 0306	120	φ90	φ91.5	B2	3	φ 6	φ20	7	10.5	M4	3.5	177.8

Catalogue number	Allowable transfer capability table for different revolutions per minute, Bending strength, (Unit: W)						
	10rpm	100rpm	200rpm	400rpm	800rpm	1,200rpm	1,500rpm
S75B 80A – 0315	1.57	15.72	31.43	60.54	102.48	140.91	170.15
S75B 85A – 0315	1.68	16.84	33.67	64.12	107.70	149.62	180.35
S75B 90A – 0315	1.80	17.97	35.94	67.69	112.84	158.34	191.18
S75B 95A – 0315	1.91	19.11	38.22	71.19	117.82	166.93	201.90
S75B 100A – 0315	2.03	20.25	40.50	74.62	123.95	175.39	212.48
S75B 105A – 0315	2.14	21.39	42.79	77.98	130.17	183.73	222.94
S75B 110A – 0315	2.25	22.54	45.08	81.28	136.32	192.36	233.28
S75B 115A – 0315	2.37	23.69	47.37	84.52	142.40	201.01	243.49
S75B 120A – 0315	2.48	24.83	49.67	87.69	148.43	209.59	253.58

CONTENTS

INFORMATION

GEARBOXES

ANTI-BACKLASH  
SPUR GEARS

**SPUR GEARS**

RACKS

HELICAL GEARS AND  
SCREW GEARS

MITER GEARS

BEVEL GEARS

WORMS AND WORM  
WHEELS

REFERENCES



Unit: mm

Accuracy Class	Material	Pressure angle	Heat treatment	Tooth surface hardness	Backlash ①
[JIS B 1702-1] N9	C3604B、C3771B	20°	—	—	0.02 to 0.06

★ No surface treatment is applied. Gears with a [+] are provided with one screw hole and set screw.

★ This allowable transfer capability table was prepared by using the formulas presented by the JGMA (Japan Gear Manufacturers Association).

For the unit conversion method, refer to P. 20 in "References."

① This is a theoretical value obtained when a pair of gears of the same type and material are meshed with each other.

Catalogue number	Number of teeth <i>z</i>	Refer-ence diameter <i>d</i>	Tip diameter <i>d<sub>a</sub></i>	Type	Face width <i>b</i>	Hole diameter <i>d<sub>a</sub>(H8)</i>	Hub diameter <i>d<sub>h</sub></i>	Hub length <i>l<sub>h</sub></i>	Overall length <i>l</i>	Screw		Weight <i>W(g)</i>
										<i>M</i>	<i>l<sub>s</sub></i>	
<b>S80B 14K + 0704</b>	14	φ11.2	φ12.8	K2	7	φ4	φ12.8	13	20	M3	3	17.8
<b>S80B 15K + 0704</b>	15	φ12	φ13.6	K2	7	φ4	φ13.6	13	20	M3	3	20.4
<b>S80B 16B + 0504</b>	16	φ12.8	φ14.4	B1	5	φ4	φ10	9	14	M3	3	9.8
<b>S80B 16B + 0704</b>	16	φ12.8	φ14.4	B1	7	φ4	φ10	7	14	M3	3	10.7
<b>S80B 18B + 0504</b>	18	φ14.4	φ16	B1	5	φ4	φ10	9	14	M3	3	11.3
<b>S80B 18B + 0704</b>	18	φ14.4	φ16	B1	7	φ4	φ10	7	14	M3	3	12.7
<b>S80B 20B + 0504</b>	20	φ16	φ17.6	B1	5	φ4	φ10	9	14	M3	3	12.9
<b>S80B 20B + 0704</b>	20	φ16	φ17.6	B1	7	φ4	φ10	7	14	M3	3	15.0
<b>S80B 24B + 0505</b>	24	φ19.2	φ20.8	B1	5	φ5	φ12.5	9	14	M3	3	19.2
<b>S80B 24B + 0705</b>	24	φ19.2	φ20.8	B1	7	φ5	φ12.5	7	14	M3	3	22.0
<b>S80B 25B + 0505</b>	25	φ20	φ21.6	B1	5	φ5	φ12.5	9	14	M3	3	20.2
<b>S80B 25B + 0705</b>	25	φ20	φ21.6	B1	7	φ5	φ12.5	7	14	M3	3	23.5
<b>S80B 28B + 0505</b>	28	φ22.4	φ24	B1	5	φ5	φ12.5	9	14	M3	3	23.6
<b>S80B 28B + 0705</b>	28	φ22.4	φ24	B1	7	φ5	φ12.5	7	14	M3	3	28.2
<b>S80B 30B + 0505</b>	30	φ24	φ25.6	B1	5	φ5	φ12.5	9	14	M3	3	26.1
<b>S80B 30B + 0705</b>	30	φ24	φ25.6	B1	7	φ5	φ12.5	7	14	M3	3	31.7
<b>S80B 32B + 0505</b>	32	φ25.6	φ27.2	B1	5	φ5	φ12.5	9	14	M3	4	28.8
<b>S80B 36B + 0506</b>	36	φ28.8	φ30.4	B1	5	φ6	φ14	9	14	M4	4	35.8
<b>S80B 40B + 0506</b>	40	φ32	φ33.6	B1	5	φ6	φ14	9	14	M4	4	42.3
<b>S80B 45B + 0506</b>	45	φ36	φ37.6	B1	5	φ6	φ14	9	14	M4	4	51.4
<b>S80B 48B + 0506</b>	48	φ38.4	φ40	B1	5	φ6	φ14	9	14	M4	4	57.3
<b>S80B 50B + 0506</b>	50	φ40	φ41.6	B1	5	φ6	φ14	9	14	M4	4	61.5
<b>S80B 56B + 0506</b>	56	φ44.8	φ46.4	B1	5	φ6	φ14	9	14	M4	4	75.1
<b>S80B 60B + 0506</b>	60	φ48	φ49.6	B1	5	φ6	φ14	9	14	M4	4	85.0
<b>S80B 64B + 0506</b>	64	φ51.2	φ52.8	B1	5	φ6	φ16	9	14	M4	4	99.1
<b>S80B 70B + 0508</b>	70	φ56	φ57.6	B1	5	φ8	φ16	9	14	M4	4	113.8
<b>S80B 72B + 0508</b>	72	φ57.6	φ59.2	B1	5	φ8	φ16	9	14	M4	4	119.8
<b>S80B 80B + 0508</b>	80	φ64	φ65.6	B1	5	φ8	φ16	9	14	M4	4	145.8



2D • 3D CAD

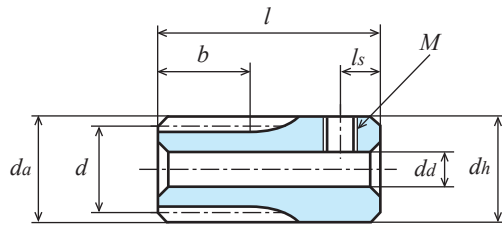

K2 type [+]

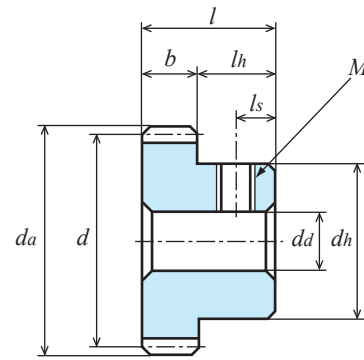

B1 type [+]

Catalogue number	Allowable transfer capability table for different revolutions per minute, Bending strength, (Unit: W)						
	10rpm	100rpm	200rpm	400rpm	800rpm	1,200rpm	1,500rpm
<b>S80B 14K + 0704</b>	0.40	3.97	7.93	15.86	31.73	47.59	59.49
<b>S80B 15K + 0704</b>	0.44	4.44	8.89	17.78	35.56	53.33	66.67
<b>S80B 16B + 0504</b>	0.35	3.52	7.05	14.09	28.19	42.28	52.81
<b>S80B 16B + 0704</b>	0.49	4.93	9.86	19.73	39.46	59.19	73.93
<b>S80B 18B + 0504</b>	0.42	4.24	8.47	16.94	33.88	50.82	62.30
<b>S80B 18B + 0704</b>	0.59	5.93	11.86	23.72	47.43	71.15	87.23
<b>S80B 20B + 0504</b>	0.50	4.97	9.95	19.89	39.78	59.63	71.83
<b>S80B 20B + 0704</b>	0.70	6.96	13.92	27.85	55.70	83.48	100.56
<b>S80B 24B + 0505</b>	0.65	6.48	12.97	25.93	51.86	75.46	90.36
<b>S80B 24B + 0705</b>	0.91	9.08	18.15	36.30	72.61	105.64	126.50
<b>S80B 25B + 0505</b>	0.69	6.87	13.74	27.47	54.95	79.37	94.90
<b>S80B 25B + 0705</b>	0.96	9.62	19.23	38.46	76.93	111.12	132.87
<b>S80B 28B + 0505</b>	0.80	8.04	16.08	32.17	64.33	90.94	108.29
<b>S80B 28B + 0705</b>	1.13	11.26	22.52	45.03	90.06	127.31	151.60
<b>S80B 30B + 0505</b>	0.88	8.83	17.66	35.32	70.58	98.45	116.92
<b>S80B 30B + 0705</b>	1.24	12.36	24.72	49.45	98.81	137.88	163.69
<b>S80B 32B + 0505</b>	0.96	9.63	19.26	38.51	76.20	105.88	125.42
<b>S80B 36B + 0506</b>	1.12	11.25	22.49	44.98	87.26	120.33	141.83
<b>S80B 40B + 0506</b>	1.28	12.88	25.77	51.53	98.05	134.24	157.49
<b>S80B 45B + 0506</b>	1.49	14.94	29.88	59.77	111.08	150.77	175.91
<b>S80B 48B + 0506</b>	1.61	16.19	32.38	64.77	118.70	160.33	186.72
<b>S80B 50B + 0506</b>	1.70	17.03	34.06	68.12	123.70	166.54	195.42
<b>S80B 56B + 0506</b>	1.96	19.55	39.11	78.21	138.25	184.44	221.21
<b>S80B 60B + 0506</b>	2.12	21.25	42.49	84.92	147.60	196.01	238.11
<b>S80B 64B + 0506</b>	2.29	22.95	45.90	90.81	156.68	210.07	254.77
<b>S80B 70B + 0508</b>	2.55	25.51	51.02	99.46	169.80	230.87	297.32
<b>S80B 72B + 0508</b>	2.64	26.37	52.73	102.30	174.05	237.72	287.38
<b>S80B 80B + 0508</b>	2.98	29.80	59.61	113.43	190.42	264.72	319.13

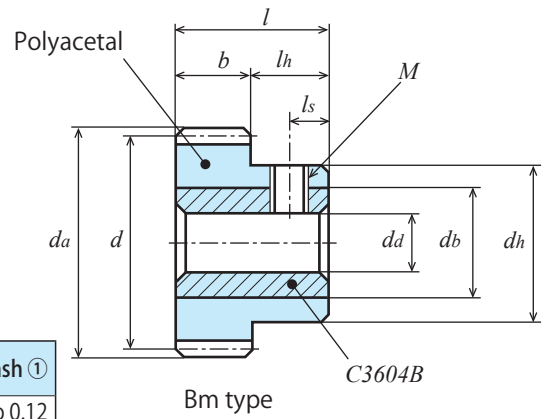

Unit: mm

Accuracy Class ②	Material	Pressure angle	Machining method	Tooth surface hardness	Backlash ①
[JIS B 1702-1] N9 to N10	White POM/C3604B	20°	Cutting	—	0.06 to 0.12

★ A brass bushing is in the hole. Gears with a [+] are provided with screw holes and set screws.

★ This allowable transfer capability table was prepared by using the Lewis formula. For the unit conversion method, refer to P. 20 in "References."

★ Because of the material characteristics, the dimensions and accuracy change with time and due to temperature changes.

① This is a theoretical value obtained when a pair of gears of the same type and material are meshed with each other. ② Accuracy at the time of manufacture.

Catalogue number	Number of teeth <i>z</i>	Reference diameter <i>d</i>	Tip diameter <i>da</i>	Type	Face width <i>b</i>	Hole diameter <i>da(H8)</i>	Hub diameter <i>dh</i>	Hub length <i>lh</i>	Overall length <i>l</i>	Screw		Bushing outside diameter <i>db</i>	Weight <i>W(g)</i>
										<i>M</i>	<i>ls</i>		
S1DB 20B + 1008	20	φ 20	φ 22	Bm	10	φ 8	φ 16	10	20	M4	4	φ 12	16.8
S1DB 24B + 1008	24	φ 24	φ 26	Bm	10	φ 8	φ 20	10	20	M4	4	φ 12	17.5
S1DB 25B + 1008	25	φ 25	φ 27	Bm	10	φ 8	φ 20	10	20	M4	4	φ 12	18.0
S1DB 28B + 1010	28	φ 28	φ 30	Bm	10	φ 10	φ 24	10	20	M4	4	φ 16	35.0
S1DB 30B + 1010	30	φ 30	φ 32	Bm	10	φ 10	φ 24	10	20	M4	4	φ 16	36.4
S1DB 32B + 1010	32	φ 32	φ 34	Bm	10	φ 10	φ 24	10	20	M4	4	φ 16	37.8
S1DB 36B + 1010	36	φ 36	φ 38	Bm	10	φ 10	φ 30	10	20	M4	4	φ 16	38.0
S1DB 40B + 1010	40	φ 40	φ 42	Bm	10	φ 10	φ 30	10	20	M4	4	φ 16	41.4
S1DB 45B + 1010	45	φ 45	φ 47	Bm	10	φ 10	φ 30	10	20	M4	4	φ 16	46.1
S1DB 48B + 1010	48	φ 48	φ 50	Bm	10	φ 10	φ 30	10	20	M4	4	φ 16	49.2
S1DB 50B + 1010	50	φ 50	φ 52	Bm	10	φ 10	φ 30	10	20	M4	4	φ 16	51.4
S1DB 60B + 1010	60	φ 60	φ 62	Bm	10	φ 10	φ 30	10	20	M4	4	φ 16	63.7
S1DB 70B + 1010	70	φ 70	φ 72	Bm	10	φ 10	φ 30	10	20	M4	4	φ 16	78.2
S1DB 80B + 1010	80	φ 80	φ 82	Bm	10	φ 10	φ 30	10	20	M4	4	φ 16	94.9
S1DB 90B + 1010	90	φ 90	φ 92	Bm	10	φ 10	φ 30	10	20	M4	4	φ 16	113.9
S1DB 100B + 1010	100	φ 100	φ 102	Bm	10	φ 10	φ 30	10	20	M4	4	φ 16	135.1
S1DB 120B + 1010	120	φ 120	φ 122	Bm	10	φ 10	φ 30	10	20	M4	4	φ 16	184.1

Catalogue number	Allowable transfer capability table for different revolutions per minute, Bending strength, (Unit: W)						
	10rpm	100rpm	200rpm	400rpm	800rpm	1,200rpm	1,500rpm
S1DB 20B + 1008	1.61	16.08	32.14	64.20	128.08	191.66	239.15
S1DB 24B + 1008	1.93	19.29	38.55	77.00	153.55	229.66	286.46
S1DB 25B + 1008	2.01	20.09	40.16	80.20	159.91	239.15	298.26
S1DB 28B + 1010	2.25	22.50	44.97	89.79	178.97	267.55	333.59
S1DB 30B + 1010	2.41	24.11	48.18	96.18	191.66	286.46	357.10
S1DB 32B + 1010	2.57	25.72	51.38	102.57	204.34	305.33	380.51
S1DB 36B + 1010	2.90	28.93	57.79	115.33	229.66	343.00	426.13
S1DB 40B + 1010	3.22	32.14	64.20	128.08	254.94	380.51	471.31
S1DB 45B + 1010	3.62	36.15	72.20	144.01	286.46	426.13	527.17
S1DB 48B + 1010	3.86	38.55	77.00	153.55	305.33	453.29	560.37
S1DB 50B + 1010	4.02	40.16	80.20	159.91	317.90	471.31	582.37
S1DB 60B + 1010	4.83	48.18	96.18	191.66	380.51	560.37	690.72
S1DB 70B + 1010	5.63	56.19	112.14	223.34	441.23	647.70	793.96
S1DB 80B + 1010	6.43	64.20	128.08	254.94	501.19	733.18	892.22
S1DB 90B + 1010	7.24	72.20	144.01	286.46	560.37	813.91	986.69
S1DB 100B + 1010	8.04	80.20	159.91	317.90	618.78	892.22	1,073.70
S1DB 120B + 1010	9.65	96.18	191.66	380.51	733.18	1,041.15	1,223.46

CONTENTS

INFORMATION

GEARBOXES

ANTI-BACKLASH  
SPUR GEARS

**SPUR GEARS**

RACKS

HELICAL GEARS AND  
SCREW GEARS

MITER GEARS

BEVEL GEARS

WORMS AND WORM  
WHEELS

REFERENCES





Unit: mm

Accuracy Class ②	Material	Pressure angle	Machining method	Tooth surface hardness	Backlash ①
[JIS B 1702-1] N9 to N10	Blue POM	20°	Cutting	—	0.02 to 0.06

★ This allowable transfer capability table was prepared by using the Lewis formula. For the unit conversion method, refer to P. 20 in "References."

★ Because of the material characteristics, the dimensions and accuracy change with time and due to temperature changes.

★ For details on blue POM, refer to P. 22.

① This is a theoretical value obtained when a pair of gears of the same type and material are meshed with each other. ② Accuracy at the time of manufacture.

Catalogue number	Number of teeth <i>z</i>	Reference diameter <i>d</i>	Tip diameter <i>d<sub>a</sub></i>	Type	Face width <i>b</i>	Hole diameter <i>d<sub>i</sub></i>	Hub diameter <i>d<sub>h</sub></i>	Hub length <i>l<sub>h</sub></i>	Overall length <i>l</i>	Weight <i>W(g)</i>
<b>S50BP 14K – 0803</b>	14	φ 7	φ 8	K2	8	φ3	φ 9	10	18	1.1
<b>S50BP 15K – 0803</b>	15	φ 7.5	φ 8.5	K2	8	φ3	φ 9	10	18	1.2
<b>S50BP 16K – 0803</b>	16	φ 8	φ 9	K2	8	φ3	φ 9	10	18	1.3
<b>S50BP 18K – 0803</b>	18	φ 9	φ10	K2	8	φ3	φ10	10	18	1.6
<b>S50BP 20B – 0503</b>	20	φ10	φ11	B1	5	φ3	φ 8	5	10	0.8
<b>S50BP 24B – 0503</b>	24	φ12	φ13	B1	5	φ3	φ10	5	10	1.2
<b>S50BP 25B – 0503</b>	25	φ12.5	φ13.5	B1	5	φ3	φ10	5	10	1.3
<b>S50BP 28B – 0503</b>	28	φ14	φ15	B1	5	φ3	φ12	5	10	1.8
<b>S50BP 30B – 0503</b>	30	φ15	φ16	B1	5	φ3	φ12	5	10	1.9
<b>S50BP 32B – 0503</b>	32	φ16	φ17	B1	5	φ3	φ14	5	10	2.4
<b>S50BP 36B – 0503</b>	36	φ18	φ19	B1	5	φ3	φ15	5	10	2.9
<b>S50BP 40B – 0503</b>	40	φ20	φ21	B1	5	φ3	φ15	5	10	3.3
<b>S50BP 45B – 0503</b>	45	φ22.5	φ23.5	B1	5	φ3	φ18	5	10	4.5
<b>S50BP 50B – 0503</b>	50	φ25	φ26	B1	5	φ3	φ20	5	10	5.6
<b>S50BP 56B – 0503</b>	56	φ28	φ29	B1	5	φ3	φ22	5	10	6.9
<b>S50BP 60B – 0503</b>	60	φ30	φ31	B1	5	φ3	φ24	5	10	8.1
<b>S50BP 64B – 0503</b>	64	φ32	φ33	B1	5	φ3	φ26	5	10	9.3
<b>S50BP 70B – 0504</b>	70	φ35	φ36	B1	5	φ4	φ26	5	10	10.3
<b>S50BP 72B – 0504</b>	72	φ36	φ37	B1	5	φ4	φ28	5	10	11.3
<b>S50BP 80B – 0504</b>	80	φ40	φ41	B1	5	φ4	φ32	5	10	14.3
<b>S50BP 90B – 0505</b>	90	φ45	φ46	B1	5	φ5	φ36	5	10	18.1
<b>S50BP 100B – 0505</b>	100	φ50	φ51	B1	5	φ5	φ40	5	10	22.4
<b>S50BP 120B – 0505</b>	120	φ60	φ61	B1	5	φ5	φ50	5	10	33.5



2D • 3D CAD

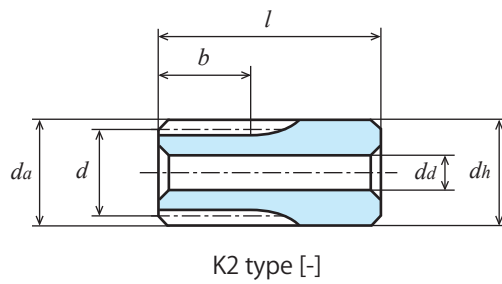

K2 type [-]

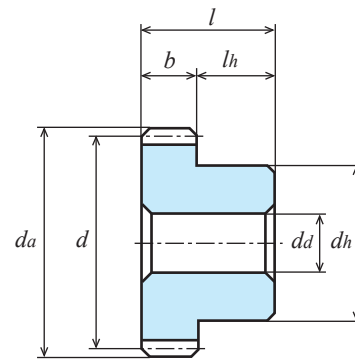

B1 type [-]

Catalogue number	Allowable transfer capability table for different revolutions per minute, Bending strength, (Unit: W)						
	10rpm	100rpm	200rpm	400rpm	800rpm	1,200rpm	1,500rpm
S50BP 14K – 0803	0.22	2.24	4.48	8.95	17.89	26.82	33.50
S50BP 15K – 0803	0.24	2.40	4.80	9.59	19.17	28.73	35.88
S50BP 16K – 0803	0.26	2.56	5.12	10.23	20.44	30.64	38.27
S50BP 18K – 0803	0.29	2.88	5.76	11.51	22.99	34.45	43.03
S50BP 20B – 0503	0.18	1.76	3.52	7.04	14.02	21.02	26.28
S50BP 24B – 0503	0.22	2.22	4.44	8.86	17.71	26.56	33.10
S50BP 25B – 0503	0.23	2.34	4.68	9.32	18.65	27.88	34.85
S50BP 28B – 0503	0.27	2.68	5.37	10.73	21.40	32.11	40.02
S50BP 30B – 0503	0.30	3.01	6.03	12.05	24.04	35.98	44.97
S50BP 32B – 0503	0.33	3.25	6.51	13.02	25.98	38.88	48.60
S50BP 36B – 0503	0.37	3.75	7.49	14.95	29.85	44.77	55.75
S50BP 40B – 0503	0.44	4.36	8.71	17.42	34.72	51.98	64.87
S50BP 45B – 0503	0.50	4.98	9.97	19.91	39.70	59.37	74.11
S50BP 50B – 0503	0.56	5.61	11.21	22.40	44.68	66.85	83.34
S50BP 56B – 0503	0.64	6.37	12.74	25.42	50.67	75.73	94.45
S50BP 60B – 0503	0.70	7.01	14.02	27.97	55.71	83.30	103.79
S50BP 64B – 0503	0.75	7.53	15.04	30.02	59.81	89.37	111.38
S50BP 70B – 0504	0.83	8.30	16.58	33.10	65.91	98.43	122.38
S50BP 72B – 0504	0.86	8.56	17.11	34.13	67.96	101.51	126.11
S50BP 80B – 0504	0.96	9.59	19.16	38.23	76.12	113.65	140.74
S50BP 90B – 0505	1.09	10.88	21.73	43.34	86.20	128.25	158.66
S50BP 100B – 0505	1.24	12.35	24.67	49.20	97.81	144.96	179.11
S50BP 120B – 0505	1.50	14.98	29.91	59.61	118.34	174.25	214.73



Unit: mm

Accuracy Class ②	Material	Pressure angle	Machining method	Tooth surface hardness	Backlash ①
[JIS B 1702-1] N9 to N10	Blue POM	20°	Cutting	—	0.02 to 0.06

★ This allowable transfer capability table was prepared by using the Lewis formula. For the unit conversion method, refer to P. 20 in "References."

★ Because of the material characteristics, the dimensions and accuracy change with time and due to temperature changes.

★ For details on blue POM, refer to P. 22.

① This is a theoretical value obtained when a pair of gears of the same type and material are meshed with each other. ② Accuracy at the time of manufacture.

Catalogue number	Number of teeth <i>z</i>	Reference diameter <i>d</i>	Tip diameter <i>d<sub>a</sub></i>	Type	Face width <i>b</i>	Hole diameter <i>d<sub>i</sub></i>	Hub diameter <i>d<sub>h</sub></i>	Hub length <i>l<sub>h</sub></i>	Overall length <i>l</i>	Weight <i>W(g)</i>
<b>S80BP 14K – 0703</b>	14	φ11.2	φ12.8	K2	7	φ3	φ12.8	13	20	3.1
<b>S80BP 15K – 0703</b>	15	φ12	φ13.6	K2	7	φ3	φ13.6	13	20	3.6
<b>S80BP 16B – 0503</b>	16	φ12.8	φ14.4	B1	5	φ3	φ10	7	12	1.5
<b>S80BP 18B – 0503</b>	18	φ14.4	φ16	B1	5	φ3	φ12	7	12	2.1
<b>S80BP 20B – 0503</b>	20	φ16	φ17.6	B1	5	φ3	φ12	7	12	2.4
<b>S80BP 22B – 0503</b>	22	φ17.6	φ19.2	B1	5	φ3	φ15	7	12	3.3
<b>S80BP 24B – 0503</b>	24	φ19.2	φ20.8	B1	5	φ3	φ16	7	12	3.9
<b>S80BP 25B – 0503</b>	25	φ20	φ21.6	B1	5	φ3	φ16	7	12	4.1
<b>S80BP 28B – 0503</b>	28	φ22.4	φ24	B1	5	φ3	φ20	7	12	5.7
<b>S80BP 30B – 0503</b>	30	φ24	φ25.6	B1	5	φ3	φ20	7	12	6.1
<b>S80BP 32B – 0503</b>	32	φ25.6	φ27.2	B1	5	φ3	φ20	7	12	6.6
<b>S80BP 36B – 0504</b>	36	φ28.8	φ30.4	B1	5	φ4	φ22	7	12	8.1
<b>S80BP 40B – 0504</b>	40	φ32	φ33.6	B1	5	φ4	φ22	7	12	9.2
<b>S80BP 45B – 0504</b>	45	φ36	φ37.6	B1	5	φ4	φ28	7	12	13.0
<b>S80BP 48B – 0504</b>	48	φ38.4	φ40	B1	5	φ4	φ30	7	12	14.9
<b>S80BP 50B – 0504</b>	50	φ40	φ41.6	B1	5	φ4	φ30	7	12	15.6
<b>S80BP 56B – 0504</b>	56	φ44.8	φ46.4	B1	5	φ4	φ35	7	12	20.4
<b>S80BP 60B – 0504</b>	60	φ48	φ49.6	B1	5	φ4	φ38	7	12	23.7
<b>S80BP 64B – 0504</b>	64	φ51.2	φ52.8	B1	5	φ4	φ38	7	12	25.4
<b>S80BP 70B – 0505</b>	70	φ56	φ57.6	B1	5	φ5	φ42	7	12	30.6
<b>S80BP 72B – 0505</b>	72	φ57.6	φ59.2	B1	5	φ5	φ45	7	12	33.7
<b>S80BP 80B – 0505</b>	80	φ64	φ65.6	B1	5	φ5	φ50	7	12	41.7
<b>S80BP 90B – 0505</b>	90	φ72	φ73.6	B1	5	φ5	φ54	7	12	50.9
<b>S80BP 100B – 0505</b>	100	φ80	φ81.6	B1	5	φ5	φ58	7	12	61.1
<b>S80BP 120B – 0505</b>	120	φ96	φ97.6	B1	5	φ5	φ68	7	12	86.4



2D • 3D CAD

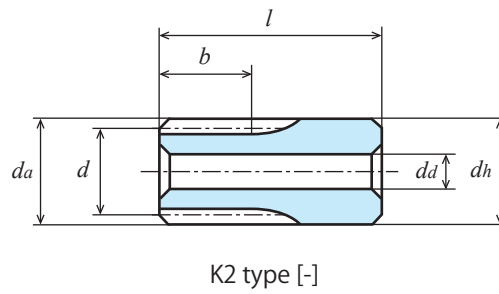

K2 type [-]

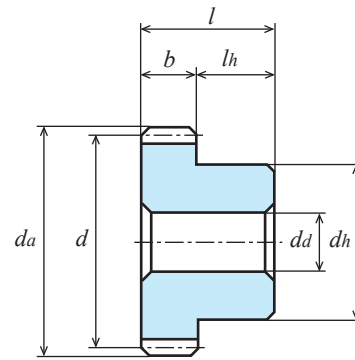

B1 type [-]

Catalogue number	Allowable transfer capability table for different revolutions per minute, Bending strength, (Unit: W)						
	10rpm	100rpm	200rpm	400rpm	800rpm	1,200rpm	1,500rpm
<b>S80BP 14K – 0703</b>	0.50	5.02	10.03	20.05	40.04	59.98	74.90
<b>S80BP 15K – 0703</b>	0.54	5.37	10.75	21.48	42.89	64.24	80.22
<b>S80BP 16B – 0503</b>	0.41	4.10	8.19	16.36	32.67	48.93	61.10
<b>S80BP 18B – 0503</b>	0.46	4.61	9.21	18.40	36.74	55.02	68.68
<b>S80BP 20B – 0503</b>	0.51	5.12	10.23	20.44	40.81	61.10	76.26
<b>S80BP 22B – 0503</b>	0.56	5.63	11.25	22.48	44.87	67.17	83.83
<b>S80BP 24B – 0503</b>	0.61	6.14	12.28	24.52	48.93	73.23	91.38
<b>S80BP 25B – 0503</b>	0.64	6.40	12.79	25.54	50.96	76.26	95.15
<b>S80BP 28B – 0503</b>	0.72	7.16	14.32	28.60	57.05	85.34	106.46
<b>S80BP 30B – 0503</b>	0.77	7.68	15.34	30.64	61.10	91.38	113.98
<b>S80BP 32B – 0503</b>	0.82	8.19	16.36	32.67	65.14	97.41	121.49
<b>S80BP 36B – 0504</b>	0.92	9.21	18.40	36.74	73.23	109.47	136.47
<b>S80BP 40B – 0504</b>	1.02	10.23	20.44	40.81	81.30	121.49	151.40
<b>S80BP 45B – 0504</b>	1.15	11.51	22.99	45.89	91.38	136.47	169.55
<b>S80BP 48B – 0504</b>	1.23	12.28	24.52	48.93	97.41	145.44	180.36
<b>S80BP 50B – 0504</b>	1.28	12.79	25.54	50.96	101.44	151.40	187.53
<b>S80BP 56B – 0504</b>	1.43	14.32	28.60	57.05	113.48	168.83	208.87
<b>S80BP 60B – 0504</b>	1.54	15.34	30.64	61.10	121.49	180.36	222.96
<b>S80BP 64B – 0504</b>	1.64	16.36	32.67	65.14	129.49	191.81	236.94
<b>S80BP 70B – 0505</b>	1.79	17.89	35.73	71.21	141.46	208.87	257.71
<b>S80BP 72B – 0505</b>	1.84	18.40	36.74	73.23	145.44	214.52	264.58
<b>S80BP 80B – 0505</b>	2.05	20.44	40.81	81.30	161.10	236.94	291.72
<b>S80BP 90B – 0505</b>	2.30	22.99	45.89	91.38	180.36	264.58	323.84
<b>S80BP 100B – 0505</b>	2.56	25.54	50.96	101.44	199.41	291.72	355.00
<b>S80BP 120B – 0505</b>	3.07	30.64	61.10	121.49	236.94	342.65	414.26



Unit: mm

Accuracy Class ②	Material	Pressure angle	Machining method	Tooth surface hardness	Backlash ①
[JIS B 1702-1] N9 to N10	Blue POM	20°	Cutting	—	0.06 to 0.12

★ This allowable transfer capability table was prepared by using the Lewis formula. For the unit conversion method, refer to P. 20 in "References."

★ Because of the material characteristics, the dimensions and accuracy change with time and due to temperature changes.

★ For details on blue POM, refer to P. 22.

① This is a theoretical value obtained when a pair of gears of the same type and material are meshed with each other.

② Accuracy at the time of manufacture.

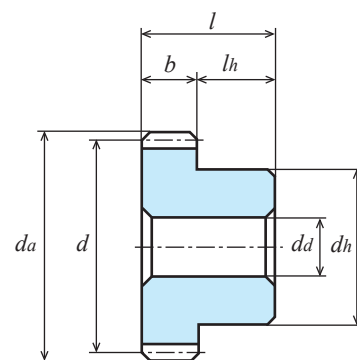

B1 type [-]

Catalogue number	Number of teeth $z$	Reference diameter $d$	Tip diameter $d_a$	Type	Face width $b$	Hole diameter $d_d$	Hub diameter $d_h$	Hub length $l_h$	Overall length $l$	Weight $W(g)$
S1BP 12B – 1004	12	$\phi$ 12	$\phi$ 14	B1	10	$\phi$ 4	$\phi$ 8	10	20	1.9
S1BP 14B – 1004	14	$\phi$ 14	$\phi$ 16	B1	10	$\phi$ 4	$\phi$ 10	10	20	2.9
S1BP 15B – 1004	15	$\phi$ 15	$\phi$ 17	B1	10	$\phi$ 4	$\phi$ 10	10	20	3.2
S1BP 16B – 1004	16	$\phi$ 16	$\phi$ 18	B1	10	$\phi$ 4	$\phi$ 12	10	20	4.0
S1BP 17B – 1004	17	$\phi$ 17	$\phi$ 19	B1	10	$\phi$ 4	$\phi$ 14	10	20	5.0
S1BP 18B – 1004	18	$\phi$ 18	$\phi$ 20	B1	10	$\phi$ 4	$\phi$ 15	10	20	5.7
S1BP 20B – 1005	20	$\phi$ 20	$\phi$ 22	B1	10	$\phi$ 5	$\phi$ 16	10	20	6.6
S1BP 22B – 1005	22	$\phi$ 22	$\phi$ 24	B1	10	$\phi$ 5	$\phi$ 18	10	20	8.3
S1BP 23B – 1005	23	$\phi$ 23	$\phi$ 25	B1	10	$\phi$ 5	$\phi$ 20	10	20	9.7
S1BP 24B – 1005	24	$\phi$ 24	$\phi$ 26	B1	10	$\phi$ 5	$\phi$ 20	10	20	10.2
S1BP 25B – 1005	25	$\phi$ 25	$\phi$ 27	B1	10	$\phi$ 5	$\phi$ 22	10	20	11.6
S1BP 26B – 1005	26	$\phi$ 26	$\phi$ 28	B1	10	$\phi$ 5	$\phi$ 22	10	20	12.2
S1BP 28B – 1005	28	$\phi$ 28	$\phi$ 30	B1	10	$\phi$ 5	$\phi$ 24	10	20	14.4
S1BP 30B – 1005	30	$\phi$ 30	$\phi$ 32	B1	10	$\phi$ 5	$\phi$ 24	10	20	15.7
S1BP 32B – 1005	32	$\phi$ 32	$\phi$ 34	B1	10	$\phi$ 5	$\phi$ 24	10	20	17.1
S1BP 34B – 1005	34	$\phi$ 34	$\phi$ 36	B1	10	$\phi$ 5	$\phi$ 24	10	20	18.5
S1BP 35B – 1005	35	$\phi$ 35	$\phi$ 37	B1	10	$\phi$ 5	$\phi$ 24	10	20	19.3
S1BP 36B – 1005	36	$\phi$ 36	$\phi$ 38	B1	10	$\phi$ 5	$\phi$ 26	10	20	21.2
S1BP 38B – 1005	38	$\phi$ 38	$\phi$ 40	B1	10	$\phi$ 5	$\phi$ 28	10	20	24.0
S1BP 40B – 1005	40	$\phi$ 40	$\phi$ 42	B1	10	$\phi$ 5	$\phi$ 30	10	20	27.0
S1BP 42B – 1005	42	$\phi$ 42	$\phi$ 44	B1	10	$\phi$ 5	$\phi$ 30	10	20	28.8
S1BP 44B – 1005	44	$\phi$ 44	$\phi$ 46	B1	10	$\phi$ 5	$\phi$ 32	10	20	32.1
S1BP 45B – 1005	45	$\phi$ 45	$\phi$ 47	B1	10	$\phi$ 5	$\phi$ 32	10	20	33.1
S1BP 48B – 1005	48	$\phi$ 48	$\phi$ 50	B1	10	$\phi$ 5	$\phi$ 36	10	20	39.2
S1BP 50B – 1005	50	$\phi$ 50	$\phi$ 52	B1	10	$\phi$ 5	$\phi$ 36	10	20	41.4
S1BP 52B – 1005	52	$\phi$ 52	$\phi$ 54	B1	10	$\phi$ 5	$\phi$ 40	10	20	47.0
S1BP 55B – 1005	55	$\phi$ 55	$\phi$ 57	B1	10	$\phi$ 5	$\phi$ 40	10	20	50.5
S1BP 56B – 1005	56	$\phi$ 56	$\phi$ 58	B1	10	$\phi$ 5	$\phi$ 40	10	20	51.7
S1BP 60B – 1005	60	$\phi$ 60	$\phi$ 62	B1	10	$\phi$ 5	$\phi$ 46	10	20	62.6
S1BP 64B – 1005	64	$\phi$ 64	$\phi$ 66	B1	10	$\phi$ 5	$\phi$ 48	10	20	70.2
S1BP 65B – 1005	65	$\phi$ 65	$\phi$ 67	B1	10	$\phi$ 5	$\phi$ 48	10	20	71.6
S1BP 70B – 1005	70	$\phi$ 70	$\phi$ 72	B1	10	$\phi$ 5	$\phi$ 52	10	20	83.5
S1BP 72B – 1005	72	$\phi$ 72	$\phi$ 74	B1	10	$\phi$ 5	$\phi$ 52	10	20	86.6
S1BP 75B – 1005	75	$\phi$ 75	$\phi$ 77	B1	10	$\phi$ 5	$\phi$ 52	10	20	91.5
S1BP 80B – 1005	80	$\phi$ 80	$\phi$ 82	B1	10	$\phi$ 5	$\phi$ 58	10	20	107.4
S1BP 85B – 1005	85	$\phi$ 85	$\phi$ 87	B1	10	$\phi$ 5	$\phi$ 62	10	20	121.8
S1BP 90B – 1005	90	$\phi$ 90	$\phi$ 92	B1	10	$\phi$ 5	$\phi$ 65	10	20	135.7
S1BP 100B – 1005	100	$\phi$ 100	$\phi$ 102	B1	10	$\phi$ 5	$\phi$ 70	10	20	164.0
S1BP 120B – 1005	120	$\phi$ 120	$\phi$ 122	B1	10	$\phi$ 5	$\phi$ 84	10	20	236.8



2D • 3D CAD

CONTENTS

INFORMATION

GEARBOXES

ANTI-BACKLASH  
SPUR GEARS

SPUR GEARS

RACKS

HELICAL GEARS AND  
SCREW GEARS

MITER GEARS

BEVEL GEARS

WORMS AND WORM  
WHEELS

REFERENCES

Catalogue number	Allowable transfer capability table for different revolutions per minute, Bending strength, (Unit: W)						
	10rpm	100rpm	200rpm	400rpm	800rpm	1,200rpm	1,500rpm
<b>S1BP 12B – 1004</b>	0.73	7.27	14.53	29.03	57.98	86.86	108.43
<b>S1BP 14B – 1004</b>	0.97	9.67	19.34	38.64	77.13	115.58	144.19
<b>S1BP 15B – 1004</b>	1.07	10.69	21.36	42.67	85.20	127.57	159.18
<b>S1BP 16B – 1004</b>	1.17	11.70	23.39	46.75	93.26	139.67	174.30
<b>S1BP 17B – 1004</b>	1.27	12.72	25.43	50.82	101.41	151.77	189.43
<b>S1BP 18B – 1004</b>	1.38	13.75	27.48	54.89	109.93	163.98	204.70
<b>S1BP 20B – 1005</b>	1.61	16.08	32.14	64.20	128.08	191.66	239.15
<b>S1BP 22B – 1005</b>	1.69	16.90	33.79	67.47	134.58	201.34	251.27
<b>S1BP 23B – 1005</b>	1.79	17.88	35.75	71.38	142.41	212.98	265.69
<b>S1BP 24B – 1005</b>	1.93	19.29	38.55	77.00	153.55	229.66	286.46
<b>S1BP 25B – 1005</b>	2.01	20.09	40.16	80.20	159.91	239.15	298.26
<b>S1BP 26B – 1005</b>	2.09	20.85	41.67	83.20	165.91	248.12	309.35
<b>S1BP 28B – 1005</b>	2.25	22.50	44.97	89.79	178.97	267.55	333.59
<b>S1BP 30B – 1005</b>	2.41	24.11	48.18	96.18	191.66	286.46	357.10
<b>S1BP 32B – 1005</b>	2.57	25.72	51.38	102.57	204.34	305.33	380.51
<b>S1BP 34B – 1005</b>	2.70	26.95	53.85	107.49	214.05	319.79	397.97
<b>S1BP 35B – 1005</b>	2.79	27.89	55.71	111.21	221.48	330.81	411.27
<b>S1BP 36B – 1005</b>	2.90	28.93	57.79	115.33	229.66	343.00	426.13
<b>S1BP 38B – 1005</b>	3.08	30.81	61.54	122.80	244.47	365.10	452.84
<b>S1BP 40B – 1005</b>	3.22	32.14	64.20	128.08	254.94	380.51	471.31
<b>S1BP 42B – 1005</b>	3.37	33.63	67.18	134.02	266.69	397.56	492.13
<b>S1BP 44B – 1005</b>	3.55	35.47	70.85	141.33	281.12	418.48	517.82
<b>S1BP 45B – 1005</b>	3.62	36.15	72.20	144.01	286.46	426.13	527.17
<b>S1BP 48B – 1005</b>	3.86	38.55	77.00	153.55	305.33	453.29	560.37
<b>S1BP 50B – 1005</b>	4.02	40.16	80.20	159.91	317.90	471.31	582.37
<b>S1BP 52B – 1005</b>	4.23	42.24	84.34	168.16	334.21	494.80	611.04
<b>S1BP 55B – 1005</b>	4.44	44.33	88.52	176.47	350.57	518.00	639.24
<b>S1BP 56B – 1005</b>	4.50	44.97	89.79	178.97	355.53	524.95	647.70
<b>S1BP 60B – 1005</b>	4.83	48.18	96.18	191.66	380.51	560.37	690.72
<b>S1BP 64B – 1005</b>	5.15	51.38	102.57	204.34	404.89	595.51	733.18
<b>S1BP 65B – 1005</b>	5.21	52.04	103.88	206.95	409.86	602.58	741.37
<b>S1BP 70B – 1005</b>	5.63	56.19	112.14	223.34	441.23	647.70	793.96
<b>S1BP 72B – 1005</b>	5.79	57.79	115.33	229.66	453.29	664.96	813.91
<b>S1BP 75B – 1005</b>	6.09	60.81	121.35	241.59	476.17	697.85	852.23
<b>S1BP 80B – 1005</b>	6.43	64.20	128.08	254.94	501.19	733.18	892.22
<b>S1BP 85B – 1005</b>	6.76	67.47	134.59	267.82	525.20	765.57	929.90
<b>S1BP 90B – 1005</b>	7.24	72.20	144.01	286.46	560.37	813.91	986.69
<b>S1BP 100B – 1005</b>	8.04	80.20	159.91	317.90	618.78	892.22	1073.70
<b>S1BP 120B – 1005</b>	9.65	96.18	191.66	380.51	733.18	1041.15	1223.46

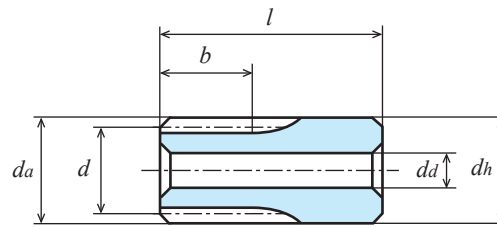

K2 type [-]

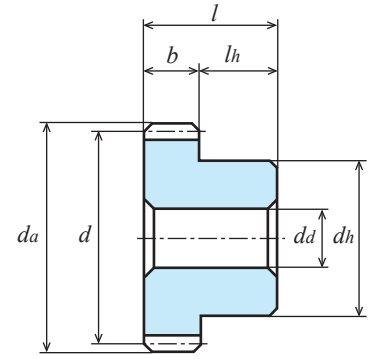

B1 type [-]

Unit: mm

Accuracy Class ②	Material	Pressure angle	Machining method	Tooth surface hardness	Backlash ①
[JIS B 1702-1] N9 to N10	Blue POM	20°	Cutting	—	0.09 to 0.18

★ This allowable transfer capability table was prepared by using the Lewis formula. For the unit conversion method, refer to P. 20 in "References."

★ Because of the material characteristics, the dimensions and accuracy change with time and due to temperature changes.

★ For details on blue POM, refer to P. 22.

① This is a theoretical value obtained when a pair of gears of the same type and material are meshed with each other. ② Accuracy at the time of manufacture.

Catalogue number	Number of teeth <i>z</i>	Reference diameter <i>d</i>	Tip diameter <i>da</i>	Type	Face width <i>b</i>	Hole diameter <i>da</i>	Hub diameter <i>dh</i>	Hub length <i>lh</i>	Overall length <i>l</i>	Weight <i>W</i> (g)
S1.5BP 14K – 1806	14	φ21	φ24	K2	18	φ 6	φ24	22	40	21.0
S1.5BP 15B – 1506	15	φ22.5	φ25.5	B1	15	φ 6	φ18	15	30	12.4
S1.5BP 16B – 1506	16	φ24	φ27	B1	15	φ 6	φ18	15	30	13.6
S1.5BP 18B – 1508	18	φ27	φ30	B1	15	φ 8	φ20	15	30	16.4
S1.5BP 20B – 1508	20	φ30	φ33	B1	15	φ 8	φ22	15	30	20.6
S1.5BP 22B – 1508	22	φ33	φ36	B1	15	φ 8	φ24	15	30	25.3
S1.5BP 24B – 1508	24	φ36	φ39	B1	15	φ 8	φ24	15	30	28.7
S1.5BP 25B – 1508	25	φ37.5	φ40.5	B1	15	φ 8	φ28	15	30	32.8
S1.5BP 26B – 1508	26	φ39	φ42	B1	15	φ 8	φ28	15	30	35.9
S1.5BP 28B – 1508	28	φ42	φ45	B1	15	φ 8	φ30	15	30	41.8
S1.5BP 30B – 1508	30	φ45	φ48	B1	15	φ 8	φ32	15	30	48.2
S1.5BP 32B – 1508	32	φ48	φ51	B1	15	φ 8	φ35	15	30	56.2
S1.5BP 35B – 1508	35	φ52.5	φ55.5	B1	15	φ 8	φ40	15	30	69.9
S1.5BP 36B – 1508	36	φ54	φ57	B1	15	φ 8	φ40	15	30	72.5
S1.5BP 40B – 1510	40	φ60	φ63	B1	15	φ10	φ45	15	30	89.7
S1.5BP 45B – 1510	45	φ67.5	φ70.5	B1	15	φ10	φ50	15	30	113.5
S1.5BP 48B – 1510	48	φ72	φ75	B1	15	φ10	φ55	15	30	132.6
S1.5BP 50B – 1510	50	φ75	φ78	B1	15	φ10	φ55	15	30	139.9
S1.5BP 55B – 1510	55	φ82.5	φ85.5	B1	15	φ10	φ60	15	30	136.8
S1.5BP 56B – 1510	56	φ84	φ87	B1	15	φ10	φ60	15	30	173.2
S1.5BP 60B – 1510	60	φ90	φ93	B1	15	φ10	φ65	15	30	200.9

Catalogue number	Allowable transfer capability table for different revolutions per minute, Bending strength, (Unit: W)						
	10rpm	100rpm	200rpm	400rpm	800rpm	1,200rpm	1,500rpm
S1.5BP 14K – 1806	1.43	14.29	28.57	57.06	113.82	170.38	212.54
S1.5BP 15B – 1506	1.58	15.79	31.55	63.01	125.73	188.06	234.53
S1.5BP 16B – 1506	1.73	17.29	34.55	69.02	137.63	205.83	256.74
S1.5BP 18B – 1508	2.03	20.31	40.59	81.07	161.61	241.63	301.27
S1.5BP 20B – 1508	2.34	23.38	46.72	93.27	185.89	277.78	346.35
S1.5BP 22B – 1508	2.65	26.45	52.85	105.49	210.11	313.93	390.88
S1.5BP 24B – 1508	2.96	29.53	58.99	117.72	234.45	350.08	434.97
S1.5BP 25B – 1508	3.11	31.07	62.07	123.88	246.64	368.29	456.96
S1.5BP 26B – 1508	3.27	32.62	65.16	130.04	258.84	386.41	478.95
S1.5BP 28B – 1508	3.58	35.73	71.37	142.38	283.29	422.30	522.82
S1.5BP 30B – 1508	4.02	40.11	80.10	159.80	317.83	472.79	584.94
S1.5BP 32B – 1508	4.34	43.33	86.54	172.58	343.16	509.38	629.80
S1.5BP 35B – 1508	4.82	48.17	96.18	191.78	381.11	564.09	696.54
S1.5BP 36B – 1508	4.99	49.79	99.41	198.18	393.77	582.21	718.75
S1.5BP 40B – 1510	5.80	57.95	115.70	230.55	457.75	674.13	830.90
S1.5BP 45B – 1510	6.64	66.26	132.26	263.44	521.14	765.61	940.19
S1.5BP 48B – 1510	7.14	71.28	142.25	283.26	559.08	820.15	1003.96
S1.5BP 50B – 1510	7.48	74.63	148.92	296.49	584.35	856.39	1045.85
S1.5BP 55B – 1510	8.32	83.00	165.59	329.53	647.04	944.88	1148.77
S1.5BP 56B – 1510	8.49	84.68	168.93	336.16	659.53	962.12	1169.00
S1.5BP 60B – 1510	9.34	93.16	185.82	369.61	723.04	1049.29	1273.12



Unit: mm

Accuracy Class ②	Material	Pressure angle	Machining method	Tooth surface hardness	Backlash ①
[JIS B 1702-1] N9 to N10	Blue POM	20°	Cutting	—	0.12 to 0.24

★ This allowable transfer capability table was prepared by using the Lewis formula. For the unit conversion method, refer to P. 20 in "References."

★ Because of the material characteristics, the dimensions and accuracy change with time and due to temperature changes.

★ For details on blue POM, refer to P. 22.

① This is a theoretical value obtained when a pair of gears of the same type and material are meshed with each other.

② Accuracy at the time of manufacture.

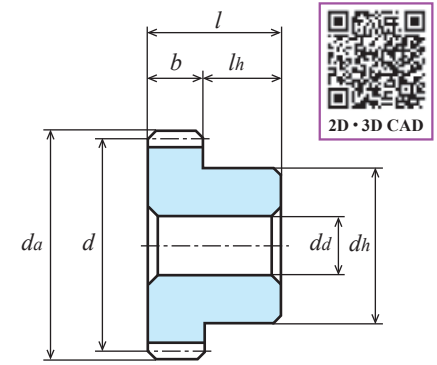

B1 type [-]

Catalogue number	Number of teeth $z$	Reference diameter $d$	Tip diameter $d_a$	Type	Face width $b$	Hole diameter $d_d$	Hub diameter $d_h$	Hub length $l_h$	Overall length $l$	Weight $W(g)$
S2BP 12B — 2008	12	φ 24	φ 28	B1	20	φ 8	φ 18	20	40	16.7
S2BP 13B — 2008	13	φ 26	φ 30	B1	20	φ 8	φ 20	20	40	20.6
S2BP 14B — 2008	14	φ 28	φ 32	B1	20	φ 8	φ 20	20	40	23.0
S2BP 15B — 2008	15	φ 30	φ 34	B1	20	φ 8	φ 22	20	40	27.4
S2BP 16B — 2010	16	φ 32	φ 36	B1	20	φ 10	φ 24	20	40	30.5
S2BP 18B — 2010	18	φ 36	φ 40	B1	20	φ 10	φ 30	20	40	43.7
S2BP 20B — 2010	20	φ 40	φ 44	B1	20	φ 10	φ 30	20	40	50.4
S2BP 22B — 2010	22	φ 44	φ 48	B1	20	φ 10	φ 32	20	40	60.6
S2BP 24B — 2010	24	φ 48	φ 52	B1	20	φ 10	φ 36	20	40	74.7
S2BP 25B — 2010	25	φ 50	φ 54	B1	20	φ 10	φ 36	20	40	79.0
S2BP 26B — 2010	26	φ 52	φ 56	B1	20	φ 10	φ 40	20	40	90.2
S2BP 28B — 2010	28	φ 56	φ 60	B1	20	φ 10	φ 40	20	40	99.8
S2BP 30B — 2010	30	φ 60	φ 64	B1	20	φ 10	φ 45	20	40	119.4
S2BP 32B — 2012	32	φ 64	φ 68	B1	20	φ 12	φ 45	20	40	128.4
S2BP 35B — 2012	35	φ 70	φ 74	B1	20	φ 12	φ 55	20	40	168.3
S2BP 36B — 2012	36	φ 72	φ 76	B1	20	φ 12	φ 55	20	40	174.6
S2BP 40B — 2012	40	φ 80	φ 84	B1	20	φ 12	φ 60	20	40	214.2
S2BP 45B — 2012	45	φ 90	φ 94	B1	20	φ 12	φ 65	20	40	265.6
S2BP 48B — 2012	48	φ 96	φ 100	B1	20	φ 12	φ 70	20	40	305.2
S2BP 50B — 2012	50	φ 100	φ 104	B1	20	φ 12	φ 75	20	40	338.6
S2BP 55B — 2012	55	φ 110	φ 114	B1	20	φ 12	φ 80	20	40	402.2
S2BP 56B — 2012	56	φ 112	φ 116	B1	20	φ 12	φ 85	20	40	430.3
S2BP 60B — 2012	60	φ 120	φ 124	B1	20	φ 12	φ 90	20	40	490.7

Catalogue number	Allowable transfer capability table for different revolutions per minute, Bending strength, (Unit: W)						
	10rpm	100rpm	200rpm	400rpm	800rpm	1,200rpm	1,500rpm
S2BP 12B — 2008	1.99	19.85	39.67	79.22	158.00	236.32	294.74
S2BP 13B — 2008	2.30	22.95	45.87	91.61	182.58	273.07	340.58
S2BP 14B — 2008	2.48	24.83	49.61	99.05	197.44	295.16	368.01
S2BP 15B — 2008	2.66	26.60	53.15	106.10	211.44	316.01	393.94
S2BP 16B — 2010	2.84	28.37	56.68	113.15	225.43	336.84	419.77
S2BP 18B — 2010	3.19	31.91	63.75	127.23	253.36	378.39	470.09
S2BP 20B — 2010	3.55	35.45	70.82	141.30	281.24	419.77	519.94
S2BP 22B — 2010	3.83	38.27	76.42	152.51	303.28	451.62	558.79
S2BP 24B — 2010	4.26	42.53	84.94	169.40	336.84	500.06	618.19
S2BP 25B — 2010	4.44	44.30	88.47	176.41	350.70	519.94	642.45
S2BP 26B — 2010	4.76	47.49	94.84	189.00	375.82	556.38	686.84
S2BP 28B — 2010	4.97	49.61	99.05	197.44	392.21	579.12	714.53
S2BP 30B — 2010	5.32	53.15	106.10	211.44	419.77	618.19	761.98
S2BP 32B — 2012	5.68	56.68	113.15	225.43	446.67	656.95	808.83
S2BP 35B — 2012	6.21	61.99	123.71	246.38	486.76	714.53	875.88
S2BP 36B — 2012	6.39	63.75	127.23	253.36	500.06	733.57	897.89
S2BP 40B — 2012	7.10	70.82	141.30	281.24	552.90	808.83	984.27
S2BP 45B — 2012	7.98	79.65	158.87	316.01	618.19	897.89	1088.49
S2BP 48B — 2012	8.52	84.94	169.40	336.84	656.95	950.04	1148.58
S2BP 50B — 2012	8.87	88.47	176.41	350.70	682.63	984.27	1184.49
S2BP 55B — 2012	9.65	96.17	191.80	381.11	737.95	1055.63	1255.42
S2BP 56B — 2012	9.94	99.05	197.44	392.21	758.83	1084.40	1286.48
S2BP 60B — 2012	10.64	106.10	211.44	419.77	808.83	1148.58	1349.70





Unit: mm

Accuracy Class ②	Material	Pressure angle	Machining method	Tooth surface hardness	Backlash ①
[JIS B 1702-1] N9 to N10	Blue POM	20°	Cutting	—	0.15 to 0.3

★ This allowable transfer capability table was prepared by using the Lewis formula. For the unit conversion method, refer to P. 20 in "References."

★ Because of the material characteristics, the dimensions and accuracy change with time and due to temperature changes.

★ For details on blue POM, refer to P. 22.

① This is a theoretical value obtained when a pair of gears of the same type and material are meshed with each other.

② Accuracy at the time of manufacture.

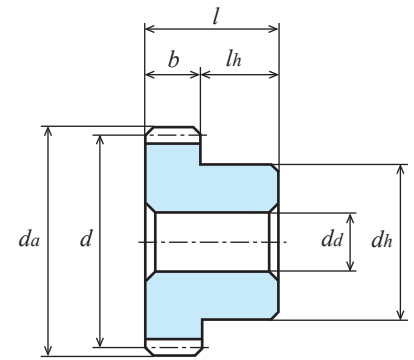

B1 type [-]

Catalogue number	Number of teeth $z$	Reference diameter $d$	Tip diameter $d_a$	Type	Face width $b$	Hole diameter $d_d$	Hub diameter $d_h$	Hub length $l_h$	Overall length $l$	Weight $W(g)$
S2.5BP 12B – 2510	12	φ 30	φ 35	B1	25	φ10	φ22	20	45	29.9
S2.5BP 13B – 2510	13	φ 32.5	φ 37.5	B1	25	φ10	φ25	20	45	37.3
S2.5BP 14B – 2510	14	φ 35	φ 40	B1	25	φ10	φ25	20	45	41.9
S2.5BP 15B – 2510	15	φ 37.5	φ 42.5	B1	25	φ10	φ30	20	45	53.0
S2.5BP 16B – 2510	16	φ 40	φ 45	B1	25	φ10	φ30	20	45	58.3
S2.5BP 18B – 2510	18	φ 45	φ 50	B1	25	φ10	φ34	20	45	75.7
S2.5BP 20B – 2512	20	φ 50	φ 55	B1	25	φ12	φ34	20	45	86.6
S2.5BP 22B – 2512	22	φ 55	φ 60	B1	25	φ12	φ40	20	45	110.9
S2.5BP 24B – 2512	24	φ 60	φ 65	B1	25	φ12	φ45	20	45	136.1
S2.5BP 25B – 2512	25	φ 62.5	φ 67.5	B1	25	φ12	φ45	20	45	144.6
S2.5BP 26B – 2512	26	φ 65	φ 70	B1	25	φ12	φ50	20	45	163.9
S2.5BP 28B – 2512	28	φ 70	φ 75	B1	25	φ12	φ50	20	45	182.5
S2.5BP 30B – 2512	30	φ 75	φ 80	B1	25	φ12	φ60	20	45	226.9
S2.5BP 32B – 2515	32	φ 80	φ 85	B1	25	φ15	φ60	20	45	244.2
S2.5BP 35B – 2515	35	φ 87.5	φ 92.5	B1	25	φ15	φ70	20	45	307.7
S2.5BP 36B – 2515	36	φ 90	φ 95	B1	25	φ15	φ70	20	45	319.9
S2.5BP 40B – 2515	40	φ100	φ105	B1	25	φ15	φ80	20	45	405.6
S2.5BP 45B – 2515	45	φ112.5	φ117.5	B1	25	φ15	φ80	20	45	479.0
S2.5BP 48B – 2515	48	φ120	φ125	B1	25	φ15	φ90	20	45	564.8
S2.5BP 50B – 2515	50	φ125	φ130	B1	25	φ15	φ90	20	45	598.7

Catalogue number	Allowable transfer capability table for different revolutions per minute, Bending strength, (Unit: W)						
	10rpm	100rpm	200rpm	400rpm	800rpm	1,200rpm	1,500rpm
S2.5BP 12B – 2510	2.50	25.00	49.93	99.69	198.67	296.96	370.21
S2.5BP 13B – 2510	2.98	29.83	59.59	118.95	236.97	354.04	441.01
S2.5BP 14B – 2510	3.33	33.27	66.47	132.67	264.23	394.68	490.71
S2.5BP 15B – 2510	3.68	36.75	73.42	146.48	291.68	435.49	540.41
S2.5BP 16B – 2510	4.03	40.24	80.40	160.41	319.24	476.48	590.22
S2.5BP 18B – 2510	4.73	47.29	94.44	188.35	374.71	557.41	689.61
S2.5BP 20B – 2512	5.45	54.42	108.68	216.71	430.77	638.68	789.12
S2.5BP 22B – 2512	6.16	61.55	122.90	245.00	486.72	719.17	887.53
S2.5BP 24B – 2512	6.88	68.71	137.17	273.35	542.66	799.21	985.05
S2.5BP 25B – 2512	7.24	72.30	144.34	287.60	570.28	839.15	1033.65
S2.5BP 26B – 2512	7.60	75.91	151.53	301.85	597.84	878.99	1081.48
S2.5BP 28B – 2512	8.33	83.14	165.92	330.44	652.85	958.33	1174.72
S2.5BP 30B – 2512	9.35	93.32	186.21	370.76	730.66	1070.84	1307.76
S2.5BP 32B – 2515	10.10	100.80	201.12	400.31	787.02	1151.32	1401.00
S2.5BP 35B – 2515	11.23	112.06	223.54	444.70	871.05	1267.43	1538.00
S2.5BP 36B – 2515	11.61	115.82	231.01	459.51	898.90	1305.60	1582.75
S2.5BP 40B – 2515	13.52	134.80	268.78	534.33	1040.05	1499.65	1804.74
S2.5BP 45B – 2515	15.46	154.11	307.17	610.18	1180.26	1686.03	1999.02
S2.5BP 48B – 2515	16.63	165.76	330.32	655.78	1263.59	1794.40	2108.53
S2.5BP 50B – 2515	17.41	173.53	345.76	685.60	1317.19	1860.02	2178.46



Unit: mm

Accuracy Class ②	Material	Pressure angle	Machining method	Tooth surface hardness	Backlash ①
[JIS B 1702-1] N9 to N10	Blue POM	20°	Cutting	—	0.18 to 0.36

★ This allowable transfer capability table was prepared by using the Lewis formula. For the unit conversion method, refer to P. 20 in "References."

★ Because of the material characteristics, the dimensions and accuracy change with time and due to temperature changes.

★ For details on blue POM, refer to P. 22.

① This is a theoretical value obtained when a pair of gears of the same type and material are meshed with each other.

② Accuracy at the time of manufacture.

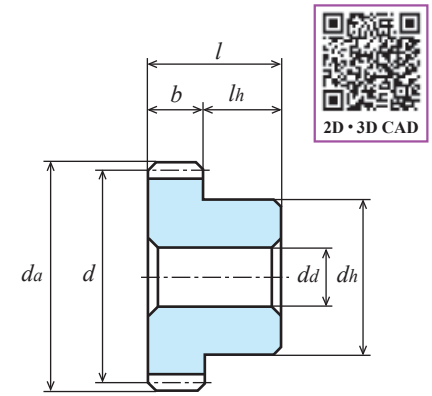

B1 type [-]

Catalogue number	Number of teeth $z$	Reference diameter $d$	Tip diameter $d_a$	Type	Face width $b$	Hole diameter $d_d$	Hub diameter $d_h$	Hub length $l_h$	Overall length $l$	Weight $W(g)$
S3BP 12B – 3012	12	φ 36	φ 42	B1	30	φ12	φ 26	20	50	48.7
S3BP 13B – 3012	13	φ 39	φ 45	B1	30	φ12	φ 30	20	50	61.1
S3BP 14B – 3012	14	φ 42	φ 48	B1	30	φ12	φ 30	20	50	69.1
S3BP 15B – 3012	15	φ 45	φ 51	B1	30	φ12	φ 34	20	50	83.4
S3BP 16B – 3012	16	φ 48	φ 54	B1	30	φ12	φ 34	20	50	92.6
S3BP 18B – 3014	18	φ 54	φ 60	B1	30	φ14	φ 40	20	50	139.7
S3BP 20B – 3014	20	φ 60	φ 66	B1	30	φ14	φ 50	20	50	162.3
S3BP 22B – 3014	22	φ 66	φ 72	B1	30	φ14	φ 50	20	50	187.3
S3BP 24B – 3014	24	φ 72	φ 78	B1	30	φ14	φ 55	20	50	226.3
S3BP 25B – 3014	25	φ 75	φ 81	B1	30	φ14	φ 55	20	50	240.9
S3BP 26B – 3014	26	φ 78	φ 84	B1	30	φ14	φ 65	20	50	282.6
S3BP 28B – 3014	28	φ 84	φ 90	B1	30	φ14	φ 65	20	50	314.8
S3BP 30B – 3014	30	φ 90	φ 96	B1	30	φ14	φ 70	20	50	364.3
S3BP 32B – 3016	32	φ 96	φ102	B1	30	φ16	φ 70	20	50	398.0
S3BP 35B – 3016	35	φ105	φ111	B1	30	φ16	φ 80	20	50	491.1
S3BP 36B – 3016	36	φ108	φ114	B1	30	φ16	φ 80	20	50	512.3
S3BP 40B – 3018	40	φ120	φ126	B1	30	φ18	φ 95	20	50	657.3
S3BP 45B – 3018	45	φ135	φ141	B1	30	φ18	φ 95	20	50	1441.4
S3BP 48B – 3018	48	φ144	φ150	B1	30	φ18	φ110	20	50	1719.6
S3BP 50B – 3018	50	φ150	φ156	B1	30	φ18	φ110	20	50	1929.4

Catalogue number	Allowable transfer capability table for different revolutions per minute, Bending strength, (Unit: W)						
	10rpm	100rpm	200rpm	400rpm	800rpm	1,200rpm	1,500rpm
S3BP 12B – 3012	5.45	54.39	108.70	216.93	431.98	645.19	801.22
S3BP 13B – 3012	6.30	62.89	125.70	250.69	499.19	745.03	923.86
S3BP 14B – 3012	6.85	68.38	136.59	272.49	542.23	808.24	1000.62
S3BP 15B – 3012	7.33	73.26	146.32	291.85	580.54	863.60	1068.39
S3BP 16B – 3012	7.82	78.14	156.05	311.19	618.79	918.64	1135.66
S3BP 18B – 3014	8.80	87.89	175.49	349.84	695.13	1027.78	1268.73
S3BP 20B – 3014	9.78	97.63	194.92	388.43	771.16	1135.66	1399.82
S3BP 22B – 3014	10.35	103.24	206.18	410.89	815.87	1201.65	1480.98
S3BP 24B – 3014	11.73	117.12	233.73	465.44	918.69	1347.62	1649.49
S3BP 25B – 3014	12.22	121.99	243.43	484.66	955.16	1399.82	1709.58
S3BP 26B – 3014	12.84	128.12	255.51	508.82	1001.51	1465.93	1785.67
S3BP 28B – 3014	13.69	136.59	272.49	542.23	1063.88	1551.92	1885.69
S3BP 30B – 3014	14.67	146.32	291.85	580.54	1135.66	1649.49	1999.64
S3BP 32B – 3016	15.65	156.05	311.19	618.79	1206.88	1745.30	2110.03
S3BP 35B – 3016	17.11	170.63	340.19	676.07	1312.65	1885.69	2255.99
S3BP 36B – 3016	17.60	175.49	349.84	695.13	1347.62	1931.61	2302.67
S3BP 40B – 3018	19.56	194.92	388.43	771.16	1485.88	2110.03	2479.51
S3BP 45B – 3018	22.00	219.18	436.59	863.60	1649.49	2302.67	-
S3BP 48B – 3018	23.46	233.73	465.44	918.64	1745.30	2410.67	-
S3BP 50B – 3018	24.44	243.43	484.66	955.16	1808.19	2479.51	-

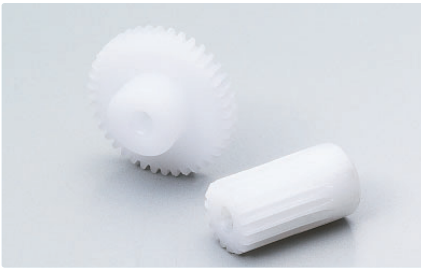

Unit: mm

Accuracy Class ②	Material	Pressure angle	Machining method	Tooth surface hardness	Backlash ①
[JIS B 1702-1] N9 to N10	White POM	20°	Cutting	—	0.02 to 0.06

★ This product is provided with a corrugated spring pin made of stainless steel. Nominal diameter of corrugated spring pin is  $\phi 1$ .

★ This allowable transfer capability table was prepared by using the Lewis formula. For the unit conversion method, refer to P. 20 in "References."

★ Because of the material characteristics, the dimensions and accuracy change with time and due to temperature changes.

① This is a theoretical value obtained when a pair of gears of the same type and material are meshed with each other. ② Accuracy at the time of manufacture.

Catalogue number	Number of teeth $z$	Reference diameter $d$	Tip diameter $d_a$	Type	Face width $b$	Hole diameter $d_i$	Hub diameter $d_h$	Hub length $l_h$	Overall length $l$	Weight $W(g)$
<b>S50D 14K – 0803</b>	14	$\phi 7$	$\phi 8$	K2	8	$\phi 3$	$\phi 9$	10	18	1.15
<b>S50D 15K – 0803</b>	15	$\phi 7.5$	$\phi 8.5$	K2	8	$\phi 3$	$\phi 9$	10	18	1.22
<b>S50D 16K – 0803</b>	16	$\phi 8$	$\phi 9$	K2	8	$\phi 3$	$\phi 9$	10	18	1.29
<b>S50D 18K – 0803</b>	18	$\phi 9$	$\phi 10$	K2	8	$\phi 3$	$\phi 10$	10	18	1.65
<b>S50D 20B – 0303</b>	20	$\phi 10$	$\phi 11$	B1	3	$\phi 3$	$\phi 8$	5	8	0.61
<b>S50D 24B – 0303</b>	24	$\phi 12$	$\phi 13$	B1	3	$\phi 3$	$\phi 8$	5	8	0.75
<b>S50D 25B – 0303</b>	25	$\phi 12.5$	$\phi 13.5$	B1	3	$\phi 3$	$\phi 8$	5	8	0.79
<b>S50D 28B – 0303</b>	28	$\phi 14$	$\phi 15$	B1	3	$\phi 3$	$\phi 8$	5	8	0.93
<b>S50D 30B – 0303</b>	30	$\phi 15$	$\phi 16$	B1	3	$\phi 3$	$\phi 8$	5	8	0.97
<b>S50D 32B – 0303</b>	32	$\phi 16$	$\phi 17$	B1	3	$\phi 3$	$\phi 8$	5	8	1.13
<b>S50D 36B – 0303</b>	36	$\phi 18$	$\phi 19$	B1	3	$\phi 3$	$\phi 8$	5	8	1.35
<b>S50D 40B – 0303</b>	40	$\phi 20$	$\phi 21$	B1	3	$\phi 3$	$\phi 10$	5	8	1.81
<b>S50D 45B – 0303</b>	45	$\phi 22.5$	$\phi 23.5$	B1	3	$\phi 3$	$\phi 10$	5	8	2.17
<b>S50D 50B – 0303</b>	50	$\phi 25$	$\phi 26$	B1	3	$\phi 3$	$\phi 10$	5	8	2.56
<b>S50D 56B – 0303</b>	56	$\phi 28$	$\phi 29$	B1	3	$\phi 3$	$\phi 10$	5	8	3.09
<b>S50D 60B – 0303</b>	60	$\phi 30$	$\phi 31$	B1	3	$\phi 3$	$\phi 10$	5	8	3.40
<b>S50D 64B – 0303</b>	64	$\phi 32$	$\phi 33$	B1	3	$\phi 3$	$\phi 10$	5	8	3.90
<b>S50D 70B – 0304</b>	70	$\phi 35$	$\phi 36$	B1	3	$\phi 4$	$\phi 12$	5	8	4.70
<b>S50D 72B – 0304</b>	72	$\phi 36$	$\phi 37$	B1	3	$\phi 4$	$\phi 12$	5	8	4.99
<b>S50D 80B – 0304</b>	80	$\phi 40$	$\phi 41$	B1	3	$\phi 4$	$\phi 12$	5	8	6.01
<b>S50D 90B – 0305</b>	90	$\phi 45$	$\phi 46$	B1	3	$\phi 5$	$\phi 14$	5	8	7.64
<b>S50D 100B – 0305</b>	100	$\phi 50$	$\phi 51$	B1	3	$\phi 5$	$\phi 14$	5	8	9.22
<b>S50D 120B – 0305</b>	120	$\phi 60$	$\phi 61$	B1	3	$\phi 5$	$\phi 14$	5	8	12.90



2D • 3D CAD

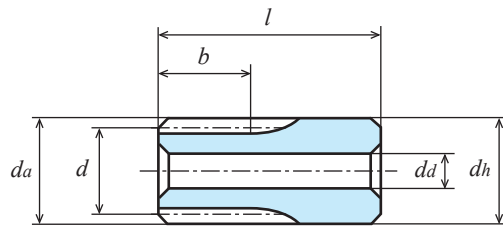

K2 type [-]

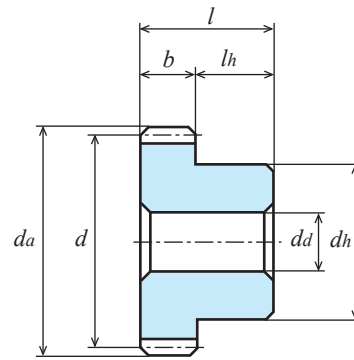

B1 type [-]

Catalogue number	Allowable transfer capability table for different revolutions per minute, Bending strength, (Unit: W)						
	10rpm	100rpm	200rpm	400rpm	800rpm	1,200rpm	1,500rpm
S50D 14K – 0803	0.22	2.24	4.48	8.95	17.89	26.82	33.50
S50D 15K – 0803	0.24	2.40	4.80	9.59	19.17	28.73	35.88
S50D 16K – 0803	0.26	2.56	5.12	10.23	20.44	30.64	38.27
S50D 18K – 0803	0.29	2.88	5.76	11.51	22.99	34.45	43.03
S50D 20B – 0303	0.12	1.20	2.40	4.79	9.58	14.35	17.92
S50D 24B – 0303	0.17	1.74	3.48	6.96	13.90	20.82	25.99
S50D 25B – 0303	0.18	1.81	3.63	7.25	14.47	21.68	27.07
S50D 28B – 0303	0.20	2.03	4.06	8.12	16.21	24.27	30.30
S50D 30B – 0303	0.22	2.18	4.35	8.70	17.36	25.99	32.45
S50D 32B – 0303	0.23	2.32	4.64	9.27	18.51	27.71	34.59
S50D 36B – 0303	0.26	2.61	5.22	10.43	20.82	31.16	38.88
S50D 40B – 0303	0.29	2.90	5.80	11.59	23.12	34.59	43.16
S50D 45B – 0303	0.33	3.26	6.52	13.03	25.99	38.88	48.50
S50D 50B – 0303	0.36	3.63	7.25	14.47	28.86	43.16	53.83
S50D 56B – 0303	0.41	4.06	8.12	16.21	32.30	48.29	60.21
S50D 60B – 0303	0.44	4.35	8.70	17.36	34.59	51.70	64.45
S50D 64B – 0303	0.46	4.64	9.27	18.51	36.88	55.11	68.68
S50D 70B – 0304	0.51	5.08	10.14	20.24	40.31	60.21	74.86
S50D 72B – 0304	0.52	5.22	10.43	20.82	41.45	61.91	76.91
S50D 80B – 0304	0.58	5.80	11.59	23.12	46.01	68.68	85.07
S50D 90B – 0305	0.65	6.52	13.03	25.99	51.70	76.91	95.15
S50D 100B – 0305	0.73	7.25	14.47	28.86	57.38	85.07	105.11
S50D 120B – 0305	0.87	8.70	17.36	34.59	68.68	101.14	124.67



Unit: mm

Accuracy Class ②	Material	Pressure angle	Machining method	Tooth surface hardness	Backlash ①
[JIS B 1702-1] N9 to N10	White POM	20°	Cutting	—	0.02 to 0.06

★ This product is provided with a corrugated spring pin made of stainless steel. (Gears with 120 teeth are not provided with a corrugated spring pin)

★ Nominal diameter of corrugated spring pin:  $\phi 1$  when the number of teeth is 14 to 64, and  $\phi 1.4$  when the number of teeth is 70 to 100.

★ This allowable transfer capability table was prepared by using the Lewis formula. For the unit conversion method, refer to P. 20 in "References."

★ Because of the material characteristics, the dimensions and accuracy change with time and due to temperature changes.

① This is a theoretical value obtained when a pair of gears of the same type and material are meshed with each other. ② Accuracy at the time of manufacture.

Catalogue number	Number of teeth <i>z</i>	Reference diameter <i>d</i>	Tip diameter <i>d<sub>a</sub></i>	Type	Face width <i>b</i>	Hole diameter <i>d<sub>i</sub></i>	Hub diameter <i>d<sub>h</sub></i>	Hub length <i>l<sub>h</sub></i>	Overall length <i>l</i>	Weight <i>W(g)</i>
<b>S80D 14K – 0704</b>	14	$\phi 11.2$	$\phi 12.8$	K2	7	$\phi 4$	$\phi 12.8$	13	20	3.0
<b>S80D 15K – 0704</b>	15	$\phi 12$	$\phi 13.6$	K2	7	$\phi 4$	$\phi 13.6$	13	20	3.4
<b>S80D 16B – 0504</b>	16	$\phi 12.8$	$\phi 14.4$	B1	5	$\phi 4$	$\phi 10$	9	14	1.7
<b>S80D 18B – 0504</b>	18	$\phi 14.4$	$\phi 16$	B1	5	$\phi 4$	$\phi 10$	9	14	1.9
<b>S80D 20B – 0504</b>	20	$\phi 16$	$\phi 17.6$	B1	5	$\phi 4$	$\phi 10$	9	14	2.2
<b>S80D 22B – 0505</b>	22	$\phi 17.6$	$\phi 19.2$	B1	5	$\phi 5$	$\phi 12.5$	9	14	2.9
<b>S80D 24B – 0505</b>	24	$\phi 19.2$	$\phi 20.8$	B1	5	$\phi 5$	$\phi 12.5$	9	14	3.2
<b>S80D 25B – 0505</b>	25	$\phi 20$	$\phi 21.6$	B1	5	$\phi 5$	$\phi 12.5$	9	14	3.4
<b>S80D 28B – 0505</b>	28	$\phi 22.4$	$\phi 24$	B1	5	$\phi 5$	$\phi 12.5$	9	14	4.0
<b>S80D 30B – 0505</b>	30	$\phi 24$	$\phi 25.6$	B1	5	$\phi 5$	$\phi 12.5$	9	14	4.4
<b>S80D 32B – 0505</b>	32	$\phi 25.6$	$\phi 27.2$	B1	5	$\phi 5$	$\phi 12.5$	9	14	4.8
<b>S80D 36B – 0506</b>	36	$\phi 28.8$	$\phi 30.4$	B1	5	$\phi 6$	$\phi 14$	9	14	6.0
<b>S80D 40B – 0506</b>	40	$\phi 32$	$\phi 33.6$	B1	5	$\phi 6$	$\phi 14$	9	14	7.1
<b>S80D 45B – 0506</b>	45	$\phi 36$	$\phi 37.6$	B1	5	$\phi 6$	$\phi 14$	9	14	8.6
<b>S80D 48B – 0506</b>	48	$\phi 38.4$	$\phi 40$	B1	5	$\phi 6$	$\phi 14$	9	14	9.6
<b>S80D 50B – 0506</b>	50	$\phi 40$	$\phi 41.6$	B1	5	$\phi 6$	$\phi 14$	9	14	10.3
<b>S80D 56B – 0506</b>	56	$\phi 44.8$	$\phi 46.4$	B1	5	$\phi 6$	$\phi 14$	9	14	12.6
<b>S80D 60B – 0506</b>	60	$\phi 48$	$\phi 49.6$	B1	5	$\phi 6$	$\phi 14$	9	14	14.2
<b>S80D 64B – 0506</b>	64	$\phi 51.2$	$\phi 52.8$	B1	5	$\phi 6$	$\phi 14$	9	14	15.9
<b>S80D 70B – 0508</b>	70	$\phi 56$	$\phi 57.6$	B1	5	$\phi 8$	$\phi 16$	9	14	19.0
<b>S80D 72B – 0508</b>	72	$\phi 57.6$	$\phi 59.2$	B1	5	$\phi 8$	$\phi 16$	9	14	20.1
<b>S80D 80B – 0508</b>	80	$\phi 64$	$\phi 65.6$	B1	5	$\phi 8$	$\phi 16$	9	14	24.2
<b>S80D 90B – 0508</b>	90	$\phi 72$	$\phi 73.6$	B1	5	$\phi 8$	$\phi 20$	9	14	31.7
<b>S80D 100B – 0508</b>	100	$\phi 80$	$\phi 81.6$	B1	5	$\phi 8$	$\phi 24$	9	14	40.2
<b>S80D 120B – 0508</b>	120	$\phi 96$	$\phi 97.6$	B1	5	$\phi 8$	$\phi 30$	9	14	59.0



2D • 3D CAD

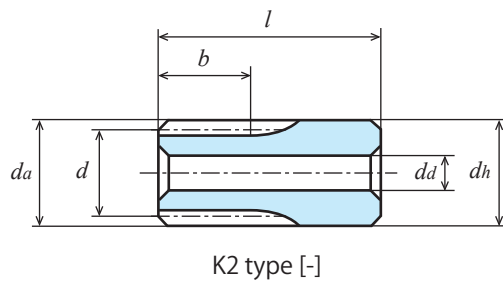

K2 type [-]

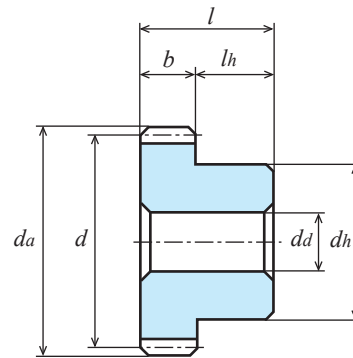

B1 type [-]

Catalogue number	Allowable transfer capability table for different revolutions per minute, Bending strength, (Unit: W)						
	10rpm	100rpm	200rpm	400rpm	800rpm	1,200rpm	1,500rpm
<b>S80D 14K – 0704</b>	0.50	5.02	10.03	20.05	40.04	59.98	74.90
<b>S80D 15K – 0704</b>	0.54	5.37	10.75	21.48	42.89	64.24	80.22
<b>S80D 16B – 0504</b>	0.41	4.10	8.19	16.36	32.67	48.93	61.10
<b>S80D 18B – 0504</b>	0.46	4.61	9.21	18.40	36.74	55.02	68.68
<b>S80D 20B – 0504</b>	0.51	5.12	10.23	20.44	40.81	61.10	76.26
<b>S80D 22B – 0505</b>	0.56	5.63	11.25	22.48	44.87	67.17	83.83
<b>S80D 24B – 0505</b>	0.61	6.14	12.28	24.52	48.93	73.23	91.38
<b>S80D 25B – 0505</b>	0.64	6.40	12.79	25.54	50.96	76.26	95.15
<b>S80D 28B – 0505</b>	0.72	7.16	14.32	28.60	57.05	85.34	106.46
<b>S80D 30B – 0505</b>	0.77	7.68	15.34	30.64	61.10	91.38	113.98
<b>S80D 32B – 0505</b>	0.82	8.19	16.36	32.67	65.14	97.41	121.49
<b>S80D 36B – 0506</b>	0.92	9.21	18.40	36.74	73.23	109.47	136.47
<b>S80D 40B – 0506</b>	1.02	10.23	20.44	40.81	81.30	121.49	151.40
<b>S80D 45B – 0506</b>	1.15	11.51	22.99	45.89	91.38	136.47	169.55
<b>S80D 48B – 0506</b>	1.23	12.28	24.52	48.93	97.41	145.44	180.36
<b>S80D 50B – 0506</b>	1.28	12.79	25.54	50.96	101.44	151.40	187.53
<b>S80D 56B – 0506</b>	1.43	14.32	28.60	57.05	113.48	168.83	208.87
<b>S80D 60B – 0506</b>	1.54	15.34	30.64	61.10	121.49	180.36	222.96
<b>S80D 64B – 0506</b>	1.64	16.36	32.67	65.14	129.49	191.81	236.94
<b>S80D 70B – 0508</b>	1.79	17.89	35.73	71.21	141.46	208.87	257.71
<b>S80D 72B – 0508</b>	1.84	18.40	36.74	73.23	145.44	214.52	264.58
<b>S80D 80B – 0508</b>	2.05	20.44	40.81	81.30	161.10	236.94	291.72
<b>S80D 90B – 0508</b>	2.30	22.99	45.89	91.38	180.36	264.58	323.84
<b>S80D 100B – 0508</b>	2.56	25.54	50.96	101.44	199.41	291.72	355.00
<b>S80D 120B – 0508</b>	3.07	30.64	61.10	121.49	236.94	342.65	414.26

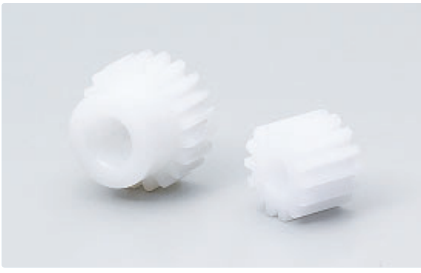

Unit: mm

Accuracy Class ②	Material	Pressure angle	Machining method	Tooth surface hardness	Backlash ①
[JIS B 1702-1] N9 to N10	White POM	20°	Cutting	—	0.02 to 0.06

★ This product is provided with a corrugated spring pin made of stainless steel. (Gears with 90 to 120 teeth are not provided with a corrugated spring pin)

★ Nominal diameter of corrugated spring pin:  $\phi 1$  when the number of teeth is 12 to 18, and  $\phi 1.4$  when the number of teeth is 20 to 80.

★ This allowable transfer capability table was prepared by using the Lewis formula. For the unit conversion method, refer to P. 20 in "References."

★ Because of the material characteristics, the dimensions and accuracy change with time and due to temperature changes.

① This is a theoretical value obtained when a pair of gears of the same type and material are meshed with each other. ② Accuracy at the time of manufacture.

Catalogue number	Number of teeth $z$	Reference diameter $d$	Tip diameter $d_a$	Type	Face width $b$	Hole diameter $d_h$	Hub diameter $d_h$	Hub length $l_h$	Overall length $l$	Weight $W(g)$
<b>S1D 12A – 1206</b>	12	$\phi 12$	$\phi 14$	A1	12	$\phi 6$	-	-	12	1.4
<b>S1D 14A – 1206</b>	14	$\phi 14$	$\phi 16$	A1	12	$\phi 6$	-	-	12	2.1
<b>S1D 15A – 1206</b>	15	$\phi 15$	$\phi 17$	A1	12	$\phi 6$	-	-	12	2.5
<b>S1D 16A – 1206</b>	16	$\phi 16$	$\phi 18$	A1	12	$\phi 6$	-	-	12	2.9
<b>S1D 17B – 0806</b>	17	$\phi 17$	$\phi 19$	B1	8	$\phi 6$	$\phi 14$	8	16	3.7
<b>S1D 18B – 0808</b>	18	$\phi 18$	$\phi 20$	B1	8	$\phi 8$	$\phi 15$	8	16	3.7
<b>S1D 20B – 0808</b>	20	$\phi 20$	$\phi 22$	B1	8	$\phi 8$	$\phi 16$	8	16	4.7
<b>S1D 22B – 0808</b>	22	$\phi 22$	$\phi 24$	B1	8	$\phi 8$	$\phi 18$	8	16	6.0
<b>S1D 23B – 0808</b>	23	$\phi 23$	$\phi 25$	B1	8	$\phi 8$	$\phi 18$	8	16	6.4
<b>S1D 24B – 0808</b>	24	$\phi 24$	$\phi 26$	B1	8	$\phi 8$	$\phi 18$	8	16	6.8
<b>S1D 25B – 0808</b>	25	$\phi 25$	$\phi 27$	B1	8	$\phi 8$	$\phi 18$	8	16	7.3
<b>S1D 26B – 0808</b>	26	$\phi 26$	$\phi 28$	B1	8	$\phi 8$	$\phi 20$	8	16	8.4
<b>S1D 28B – 0808</b>	28	$\phi 28$	$\phi 30$	B1	8	$\phi 8$	$\phi 20$	8	16	9.4
<b>S1D 30B – 0808</b>	30	$\phi 30$	$\phi 32$	B1	8	$\phi 8$	$\phi 20$	8	16	10.4
<b>S1D 32B – 0608</b>	32	$\phi 32$	$\phi 34$	B1	6	$\phi 8$	$\phi 20$	8	14	9.4
<b>S1D 34B – 0608</b>	34	$\phi 34$	$\phi 36$	B1	6	$\phi 8$	$\phi 20$	8	14	10.2
<b>S1D 35B – 0608</b>	35	$\phi 35$	$\phi 37$	B1	6	$\phi 8$	$\phi 20$	8	14	10.7
<b>S1D 36B – 0608</b>	36	$\phi 36$	$\phi 38$	B1	6	$\phi 8$	$\phi 20$	8	14	11.2
<b>S1D 40B – 0608</b>	40	$\phi 40$	$\phi 42$	B1	6	$\phi 8$	$\phi 20$	8	14	13.2
<b>S1D 42B – 0608</b>	42	$\phi 42$	$\phi 44$	B1	6	$\phi 8$	$\phi 20$	8	14	14.3
<b>S1D 44B – 0608</b>	44	$\phi 44$	$\phi 46$	B1	6	$\phi 8$	$\phi 20$	8	14	15.4
<b>S1D 45B – 0608</b>	45	$\phi 45$	$\phi 47$	B1	6	$\phi 8$	$\phi 20$	8	14	16.0
<b>S1D 48B – 0608</b>	48	$\phi 48$	$\phi 50$	B1	6	$\phi 8$	$\phi 20$	8	14	17.9
<b>S1D 50B – 0608</b>	50	$\phi 50$	$\phi 52$	B1	6	$\phi 8$	$\phi 20$	8	14	19.2
<b>S1D 52B – 0608</b>	52	$\phi 52$	$\phi 54$	B1	6	$\phi 8$	$\phi 20$	8	14	20.5
<b>S1D 55B – 0608</b>	55	$\phi 55$	$\phi 57$	B1	6	$\phi 8$	$\phi 20$	8	14	22.7
<b>S1D 56B – 0608</b>	56	$\phi 56$	$\phi 58$	B1	6	$\phi 8$	$\phi 20$	8	14	23.4
<b>S1D 60B – 0608</b>	60	$\phi 60$	$\phi 62$	B1	6	$\phi 8$	$\phi 20$	8	14	26.5
<b>S1D 64B – 0608</b>	64	$\phi 64$	$\phi 66$	B1	6	$\phi 8$	$\phi 20$	8	14	29.8
<b>S1D 70B – 0608</b>	70	$\phi 70$	$\phi 72$	B1	6	$\phi 8$	$\phi 20$	8	14	35.1
<b>S1D 72B – 0608</b>	72	$\phi 72$	$\phi 74$	B1	6	$\phi 8$	$\phi 20$	8	14	37.0
<b>S1D 80B – 0608</b>	80	$\phi 80$	$\phi 82$	B1	6	$\phi 8$	$\phi 20$	8	14	45.1
<b>S1D 90B – 0608</b>	90	$\phi 90$	$\phi 92$	B1	6	$\phi 8$	$\phi 30$	8	14	60.8
<b>S1D 100B – 0608</b>	100	$\phi 100$	$\phi 102$	B1	6	$\phi 8$	$\phi 30$	8	14	73.4
<b>S1D 120B – 0608</b>	120	$\phi 120$	$\phi 122$	B1	6	$\phi 8$	$\phi 30$	8	14	102.7



2D • 3D CAD

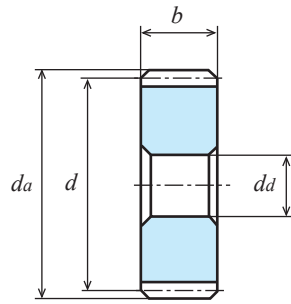

A1 type [-]

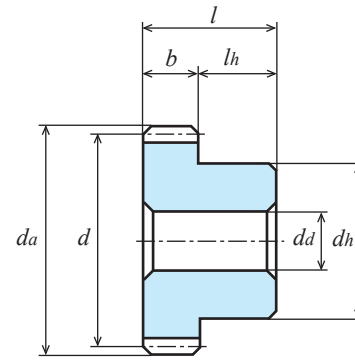

B1 type [-]

Catalogue number	Allowable transfer capability table for different revolutions per minute, Bending strength, (Unit: W)						
	10rpm	100rpm	200rpm	400rpm	800rpm	1,200rpm	1,500rpm
<b>S1D 12A – 1206</b>	0.88	8.82	17.64	35.25	70.40	105.44	131.66
<b>S1D 14A – 1206</b>	1.03	10.29	20.57	41.11	82.09	122.93	153.47
<b>S1D 15A – 1206</b>	1.10	11.03	22.04	44.05	87.93	131.66	164.35
<b>S1D 16A – 1206</b>	1.18	11.76	23.51	46.98	93.77	140.39	175.23
<b>S1D 17B – 0806</b>	0.83	8.33	16.65	33.27	66.41	99.41	124.07
<b>S1D 18B – 0808</b>	0.88	8.82	17.63	35.22	70.30	105.22	131.31
<b>S1D 20B – 0808</b>	0.98	9.80	19.59	39.13	78.07	116.82	145.76
<b>S1D 22B – 0808</b>	1.08	10.78	21.54	43.03	85.83	128.41	160.19
<b>S1D 23B – 0808</b>	1.13	11.27	22.52	44.98	89.71	134.20	167.40
<b>S1D 24B – 0808</b>	1.18	11.76	23.50	46.93	93.59	139.98	174.60
<b>S1D 25B – 0808</b>	1.23	12.25	24.48	48.88	97.47	145.76	181.79
<b>S1D 26B – 0808</b>	1.27	12.74	25.45	50.83	101.34	151.54	188.98
<b>S1D 28B – 0808</b>	1.37	13.72	27.41	54.73	109.09	163.08	203.33
<b>S1D 30B – 0808</b>	1.47	14.70	29.36	58.62	116.82	174.60	217.65
<b>S1D 32B – 0608</b>	2.10	20.97	41.90	83.65	166.65	249.01	310.33
<b>S1D 34B – 0608</b>	2.23	22.28	44.52	88.85	176.98	264.39	328.97
<b>S1D 35B – 0608</b>	2.30	22.94	45.82	91.46	182.14	272.06	338.26
<b>S1D 36B – 0608</b>	2.36	23.59	47.13	94.06	187.30	279.73	347.53
<b>S1D 38B – 0608</b>	2.49	24.90	49.74	99.26	197.61	295.06	366.00
<b>S1D 40B – 0608</b>	2.62	26.21	52.36	104.46	207.91	310.33	384.38
<b>S1D 42B – 0608</b>	2.75	27.52	54.97	109.66	218.20	325.25	402.67
<b>S1D 44B – 0608</b>	2.89	28.83	57.58	114.85	228.48	340.12	420.87
<b>S1D 45B – 0608</b>	2.9	28.92	57.76	115.21	229.17	340.98	421.74
<b>S1D 48B – 0608</b>	3.15	31.44	62.80	125.23	249.01	369.68	457.01
<b>S1D 50B – 0608</b>	3.28	32.75	65.40	130.42	259.26	384.38	474.95
<b>S1D 52B – 0608</b>	3.41	34.06	68.01	135.60	269.50	399.02	492.80
<b>S1D 55B – 0608</b>	3.61	36.02	71.92	143.37	284.84	420.87	519.41
<b>S1D 56B – 0608</b>	3.67	36.68	73.23	145.96	289.95	428.13	528.23
<b>S1D 60B – 0608</b>	3.94	39.29	78.44	156.31	310.33	457.01	563.31
<b>S1D 64B – 0608</b>	4.20	41.92	83.65	166.65	330.21	485.67	597.95
<b>S1D 70B – 0608</b>	4.59	45.82	91.46	182.14	359.85	528.23	647.51
<b>S1D 72B – 0608</b>	4.72	47.13	94.06	187.30	369.68	542.31	663.79
<b>S1D 80B – 0608</b>	5.25	52.36	104.46	207.91	408.74	597.95	727.65
<b>S1D 90B – 0608</b>	5.90	58.88	117.45	233.62	457.01	663.79	804.69
<b>S1D 100B – 0608</b>	6.56	65.40	130.42	259.26	504.65	727.65	875.66
<b>S1D 120B – 0608</b>	7.87	78.44	156.31	310.33	597.95	849.11	997.80





Unit: mm

Accuracy Class ②	Material	Pressure angle	Machining method	Tooth surface hardness	Backlash ①
[JIS B 1702-1] N9 to N10	White POM	20°	Cutting	—	0.02 to 0.06

★ Gears with a [\*] are provided with two screw holes and two set screws.

★ This allowable transfer capability table was prepared by using the Lewis formula. For the unit conversion method, refer to P. 20 in "References."

★ Because of the material characteristics, the dimensions and accuracy change with time and due to temperature changes.

① This is a theoretical value obtained when a pair of gears of the same type and material are meshed with each other. ② Accuracy at the time of manufacture.

Catalogue number	Number of teeth <i>z</i>	Refer- ence diameter <i>d</i>	Tip diameter <i>d<sub>a</sub></i>	Type	Face width <i>b</i>	Hole diameter <i>d<sub>i</sub></i>	Hub diameter <i>d<sub>h</sub></i>	Hub length <i>l<sub>h</sub></i>	Overall length <i>l</i>	Screw		Weight <i>W(g)</i>
										2-M(120°)	<i>l<sub>s</sub></i>	
<b>S50D 14K * 0803</b>	14	φ 7	φ 8	K2	8	φ3	φ 9	10	18	2-M3	3	1.10
<b>S50D 15K * 0803</b>	15	φ 7.5	φ 8.5	K2	8	φ3	φ 9	10	18	2-M3	3	1.17
<b>S50D 18K * 0803</b>	18	φ 9	φ10	K2	8	φ3	φ10	10	18	2-M3	3	1.59
<b>S50D 20B * 0303</b>	20	φ10	φ11	B1	3	φ3	φ 8	5	8	2-M3	3	0.57
<b>S50D 24B * 0303</b>	24	φ12	φ13	B1	3	φ3	φ10	5	8	2-M3	3	0.90
<b>S50D 30B * 0303</b>	30	φ15	φ16	B1	3	φ3	φ12	5	8	2-M3	3	1.39
<b>S50D 32B * 0303</b>	32	φ16	φ17	B1	3	φ3	φ14	5	8	2-M3	3	1.77
<b>S50D 36B * 0303</b>	36	φ18	φ19	B1	3	φ3	φ15	5	8	2-M3	3	2.15
<b>S50D 40B * 0303</b>	40	φ20	φ21	B1	3	φ3	φ15	5	8	2-M3	3	2.40
<b>S50D 45B * 0303</b>	45	φ22.5	φ23.5	B1	3	φ3	φ15	5	8	2-M3	3	2.75
<b>S50D 50B * 0303</b>	50	φ25	φ26	B1	3	φ3	φ15	5	8	2-M3	3	3.15
<b>S50D 56B * 0303</b>	56	φ28	φ29	B1	3	φ3	φ15	5	8	2-M3	3	3.67
<b>S50D 60B * 0303</b>	60	φ30	φ31	B1	3	φ3	φ15	5	8	2-M3	3	4.06
<b>S50D 64B * 0303</b>	64	φ32	φ33	B1	3	φ3	φ15	5	8	2-M3	3	4.47
<b>S50D 70B * 0304</b>	70	φ35	φ36	B1	3	φ4	φ16	5	8	2-M3	3	5.25
<b>S50D 72B * 0304</b>	72	φ36	φ37	B1	3	φ4	φ16	5	8	2-M3	3	5.48
<b>S50D 80B * 0304</b>	80	φ40	φ41	B1	3	φ4	φ16	5	8	2-M3	3	6.49
<b>S50D 90B * 0305</b>	90	φ45	φ46	B1	3	φ5	φ18	5	8	2-M3	3	8.20
<b>S50D 100B * 0305</b>	100	φ50	φ51	B1	3	φ5	φ18	5	8	2-M3	3	9.77
<b>S50D 120B * 0305</b>	120	φ60	φ61	B1	3	φ5	φ18	5	8	2-M3	3	13.43



2D • 3D CAD

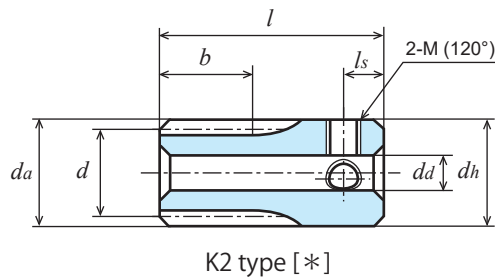

K2 type [\*]

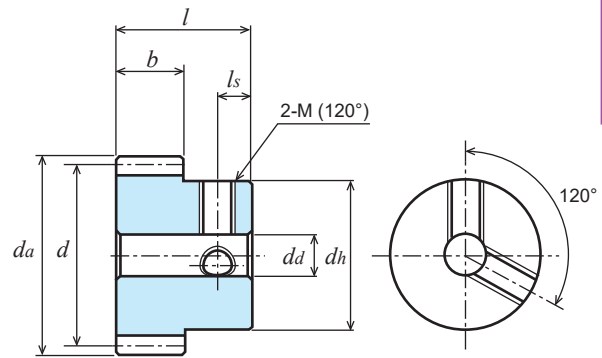

B1 type [\*]

Catalogue number	Allowable transfer capability table for different revolutions per minute, Bending strength, (Unit: W)						
	10rpm	100rpm	200rpm	400rpm	800rpm	1,200rpm	1,500rpm
S50D 14K * 0803	0.22	2.24	4.48	8.95	17.89	26.82	33.50
S50D 15K * 0803	0.24	2.40	4.80	9.59	19.17	28.73	35.88
S50D 18K * 0803	0.29	2.88	5.76	11.51	22.99	34.45	43.03
S50D 20B * 0303	0.12	1.20	2.40	4.79	9.58	14.35	17.92
S50D 24B * 0303	0.17	1.74	3.48	6.96	13.90	20.82	25.99
S50D 30B * 0303	0.22	2.18	4.35	8.70	17.36	25.99	32.45
S50D 32B * 0303	0.23	2.32	4.64	9.27	18.51	27.71	34.59
S50D 36B * 0303	0.26	2.61	5.22	10.43	20.82	31.16	38.88
S50D 40B * 0303	0.29	2.90	5.80	11.59	23.12	34.59	43.16
S50D 45B * 0303	0.33	3.26	6.52	13.03	25.99	38.88	48.50
S50D 50B * 0303	0.36	3.63	7.25	14.47	28.86	43.16	53.83
S50D 56B * 0303	0.41	4.06	8.12	16.21	32.30	48.29	60.21
S50D 60B * 0303	0.44	4.35	8.70	17.36	34.59	51.70	64.45
S50D 64B * 0303	0.46	4.64	9.27	18.51	36.88	55.11	68.68
S50D 70B * 0304	0.51	5.08	10.14	20.24	40.31	60.21	74.86
S50D 72B * 0304	0.52	5.22	10.43	20.82	41.45	61.91	76.91
S50D 80B * 0304	0.58	5.80	11.59	23.12	46.01	68.68	85.07
S50D 90B * 0305	0.65	6.52	13.03	25.99	51.70	76.91	95.15
S50D 100B * 0305	0.73	7.25	14.47	28.86	57.38	85.07	105.11
S50D 120B * 0305	0.87	8.70	17.36	34.59	68.68	101.14	124.67

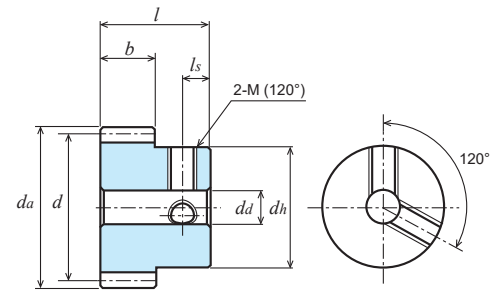

B1 type [\*]

Unit: mm

Accuracy Class ②	Material	Pressure angle	Machining method	Tooth surface hardness	Backlash ①
[JIS B 1702-1] N9 to N10	White POM	20°	Cutting	—	0.06 to 0.12

★ Gears with a [\*] are provided with two screw holes and two set screws.

★ This allowable transfer capability table was prepared by using the Lewis formula. For the unit conversion method, refer to P. 20 in "References."

★ Because of the material characteristics, the dimensions and accuracy change with time and due to temperature changes.

① This is a theoretical value obtained when a pair of gears of the same type and material are meshed with each other. ② Accuracy at the time of manufacture.

Catalogue number	Number of teeth <i>z</i>	Refer-ence diameter <i>d</i>	Tip diameter <i>da</i>	Type	Face width <i>b</i>	Hole diameter <i>dd</i>	Hub diameter <i>dh</i>	Hub length <i>lh</i>	Overall length <i>l</i>	Screw		Weight <i>W(g)</i>
										2-M(120°)	<i>ls</i>	
<b>S80D 16B * 0503</b>	16	φ12.8	φ14.4	B1	5	φ3	φ10	7	12	2-M3	4	1.5
<b>S80D 20B * 0503</b>	20	φ16	φ17.6	B1	5	φ3	φ12	7	12	2-M3	4	2.4
<b>S80D 25B * 0503</b>	25	φ20	φ21.6	B1	5	φ3	φ16	7	12	2-M3	4	4.0
<b>S80D 28B * 0503</b>	28	φ22.4	φ24	B1	5	φ3	φ20	7	12	2-M3	4	5.7
<b>S80D 30B * 0503</b>	30	φ24	φ25.6	B1	5	φ3	φ20	7	12	2-M3	4	6.1
<b>S80D 32B * 0503</b>	32	φ25.6	φ27.2	B1	5	φ3	φ20	7	12	2-M3	4	6.6
<b>S80D 36B * 0504</b>	36	φ28.8	φ30.4	B1	5	φ4	φ22	7	12	2-M4	4	8.1
<b>S80D 40B * 0504</b>	40	φ32	φ33.6	B1	5	φ4	φ22	7	12	2-M4	4	9.2
<b>S80D 60B * 0504</b>	60	φ48	φ49.6	B1	5	φ4	φ22	7	12	2-M4	4	16.3

Catalogue number	Allowable transfer capability table for different revolutions per minute, Bending strength, (Unit: W)						
	10rpm	100rpm	200rpm	400rpm	800rpm	1,200rpm	1,500rpm
<b>S80D 16B * 0503</b>	0.41	4.10	8.19	16.36	32.67	48.93	61.10
<b>S80D 20B * 0503</b>	0.51	5.12	10.23	20.44	40.81	61.10	76.26
<b>S80D 25B * 0503</b>	0.64	6.40	12.79	25.54	50.96	76.26	95.15
<b>S80D 28B * 0503</b>	0.72	7.16	14.32	28.60	57.05	85.34	106.46
<b>S80D 30B * 0503</b>	0.77	7.68	15.34	30.64	61.10	91.38	113.98
<b>S80D 32B * 0503</b>	0.82	8.19	16.36	32.67	65.14	97.41	121.49
<b>S80D 36B * 0504</b>	0.92	9.21	18.40	36.74	73.23	109.47	136.47
<b>S80D 40B * 0504</b>	1.02	10.23	20.44	40.81	81.30	121.49	151.40
<b>S80D 60B * 0504</b>	1.54	15.34	30.64	61.10	121.49	180.36	222.96

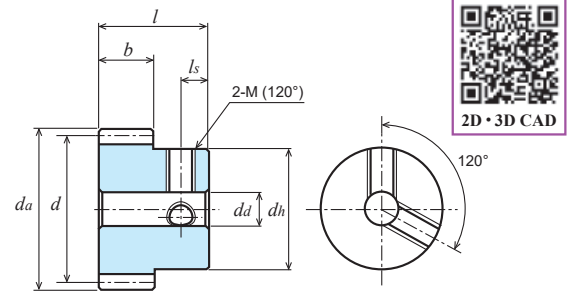

Unit: mm

B1 type [\*]

Accuracy Class ②	Material	Pressure angle	Machining method	Tooth surface hardness	Backlash ①
[JIS B 1702-1] N9 to N10	White POM	20°	Cutting	—	0.06 to 0.12

★ Gears with a [\*] are provided with two screw holes and two set screws.

★ This allowable transfer capability table was prepared by using the Lewis formula. For the unit conversion method, refer to P. 20 in "References."

★ Because of the material characteristics, the dimensions and accuracy change with time and due to temperature changes.

① This is a theoretical value obtained when a pair of gears of the same type and material are meshed with each other. ② Accuracy at the time of manufacture.

Catalogue number	Number of teeth <i>z</i>	Refer-ence diameter <i>d</i>	Tip diameter <i>da</i>	Type	Face width <i>b</i>	Hole diameter <i>da</i>	Hub diameter <i>dh</i>	Hub length <i>lh</i>	Overall length <i>l</i>	Screw		Weight <i>W(g)</i>
										2-M(120°)	<i>ls</i>	
S1D 17B * 0804	17	φ 17	φ 19	B1	8	φ4	φ14	8	16	2-M4	4	4.0
S1D 18B * 0804	18	φ 18	φ 20	B1	8	φ4	φ15	8	16	2-M4	4	4.5
S1D 20B * 0805	20	φ 20	φ 22	B1	8	φ5	φ16	8	16	2-M4	4	5.3
S1D 24B * 0805	24	φ 24	φ 26	B1	8	φ5	φ20	8	16	2-M4	4	8.2
S1D 25B * 0805	25	φ 25	φ 27	B1	8	φ5	φ22	8	16	2-M4	4	9.3
S1D 26B * 0805	26	φ 26	φ 28	B1	8	φ5	φ22	8	16	2-M4	4	9.8
S1D 30B * 0805	30	φ 30	φ 32	B1	8	φ5	φ24	8	16	2-M4	4	12.6
S1D 32B * 0605	32	φ 32	φ 34	B1	6	φ5	φ24	8	14	2-M4	4	11.5
S1D 36B * 0605	36	φ 36	φ 38	B1	6	φ5	φ24	8	14	2-M4	4	13.3
S1D 38B * 0605	38	φ 38	φ 40	B1	6	φ5	φ24	8	14	2-M4	4	14.3
S1D 40B * 0605	40	φ 40	φ 42	B1	6	φ5	φ24	8	14	2-M4	4	15.3
S1D 48B * 0605	48	φ 48	φ 50	B1	6	φ5	φ24	8	14	2-M4	4	20.0
S1D 50B * 0605	50	φ 50	φ 52	B1	6	φ5	φ24	8	14	2-M4	4	21.3
S1D 60B * 0605	60	φ 60	φ 62	B1	6	φ5	φ24	8	14	2-M4	4	28.6
S1D 64B * 0605	64	φ 64	φ 66	B1	6	φ5	φ24	8	14	2-M4	4	31.9
S1D 72B * 0605	72	φ 72	φ 74	B1	6	φ5	φ24	8	14	2-M4	4	39.1
S1D 80B * 0605	80	φ 80	φ 82	B1	6	φ5	φ24	8	14	2-M4	4	47.2

Catalogue number	Allowable transfer capability table for different revolutions per minute, Bending strength, (Unit: W)						
	10rpm	100rpm	200rpm	400rpm	800rpm	1,200rpm	1,500rpm
S1D 17B * 0804	0.83	8.33	16.65	33.27	66.41	99.41	124.07
S1D 18B * 0804	0.88	8.82	17.63	35.22	70.30	105.22	131.31
S1D 20B * 0805	0.98	9.80	19.59	39.13	78.07	116.82	145.76
S1D 24B * 0805	1.18	11.76	23.50	46.93	93.59	139.98	174.60
S1D 25B * 0805	1.23	12.25	24.48	48.88	97.47	145.76	181.79
S1D 26B * 0805	1.27	12.74	25.45	50.83	101.34	151.54	188.98
S1D 30B * 0805	1.47	14.70	29.36	58.62	116.82	174.60	217.65
S1D 32B * 0605	2.10	20.97	41.90	83.65	166.65	249.01	310.33
S1D 36B * 0605	2.36	23.59	47.13	94.06	187.30	279.73	347.53
S1D 38B * 0605	2.49	24.90	49.74	99.26	197.61	295.06	366.00
S1D 40B * 0605	2.62	26.21	52.36	104.46	207.91	310.33	384.38
S1D 48B * 0605	3.15	31.44	62.80	125.23	249.01	369.68	457.01
S1D 50B * 0605	3.28	32.75	65.40	130.42	259.26	384.38	474.95
S1D 60B * 0605	3.94	39.29	78.44	156.31	310.33	457.01	563.31
S1D 64B * 0605	4.20	41.92	83.65	166.65	330.21	485.67	597.95
S1D 72B * 0605	4.72	47.13	94.06	187.30	369.68	542.31	663.79
S1D 80B * 0605	5.25	52.36	104.46	207.91	408.74	597.95	727.65

CONTENTS

INFORMATION

GEARBOXES

ANTI-BACKLASH  
SPUR GEARS

**SPUR GEARS**

RACKS

HELICAL GEARS AND  
SCREW GEARS

MITTER GEARS

BEVEL GEARS

WORMS AND WORM  
WHEELS

REFERENCES

Module size

# Rack gears

## RK series

## ORK series



\* These are samples

### How to Read Catalogue Numbers

**RK 1.5 SD 10 – 16 16**

Gear type	Module	Material	Overall length		Face width	Height
RK: Rack gear	Represents the module size. When the module is less than 1, it indicates a value 100 times the actual module. Example: Module 0.5 → "50" Module 0.8 → "80"	SD: S45C SU: Stainless steel SUS304 B : Brass C3604B BP: Acetal Blue POM	Unit: mm The actual length indicates a value 100 times. Example: 2 → "200mm" 3 → "300mm"		Unit: mm	Unit: mm

**ORK 50 SU 2 – 08 15**

Gear type	Module	Material	Overall length		Face width	Effective contact length
ORK: Round rack gear	Represents the module size. When the module is less than 1, it indicates a value 100 times the actual module. Example: Module 0.5 → "50" Module 0.8 → "80"	SU: Stainless steel SUS304	Unit: mm The actual length indicates a value 100 times. Example: 2 → "200mm" 3 → "300mm"		Unit: mm	Unit: mm The actual length indicates a value 10 times.

Catalogue number	RK	ORK	RK	RK	RK
Shape					
Page	P. 183	P. 184	P. 184	P. 185	P. 185
Material	S45C	SUS304	SUS304	Brass	Blue POM
Module	m1 to 3	m0.5 to 1	m0.5 to 1.5	m0.3 to 0.8	m0.5 to 1
Heat treatment	—	—	—	—	—
Teeth process sequence	Cutting	Cutting	Cutting	Cutting	Cutting

# Rack gear information

CONTENTS  
INFORMATION  
GEARBOXES  
ANTI-BACKLASH SPUR GEARS  
SPUR GEARS  
RACKS  
HELICAL GEARS AND SCREW GEARS  
MITER GEARS  
BEVEL GEARS  
WORMS AND WORM WHEELS  
REFERENCES

## Both-end machining (pitch alignment machining for coupling)

Our racks are finished to have a both-end machining dimension P so that one rack can be coupled to another.

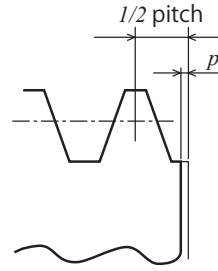

Rack end machining shape

## How to calculate the rack assembly distance

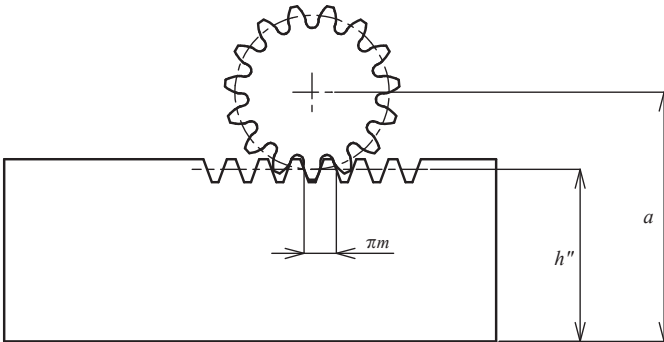

$$a = h'' + \frac{m \times z}{2} + xm$$

Explanation

$a$  : Assembly distance (distance from the rack bottom to the spur gear center)

$h''$  : Rack datum line

$m$  : Module

$x$  : Rack shift coefficient

$z$  : Number of teeth

(When the module is 1 or more:  
 $x = 0.5$  when the number of teeth is 8 to 11  
 $x = 0$  when the number teeth is 12 or more)

\*This is for our standard products.

## How to couple racks

When coupling multiple racks, align their pitch by using another rack as shown in the figure to the right in order to set the optimal pitch between racks ㊶ and ㊷.

Note: We do not offer racks designed exclusively for coupling.

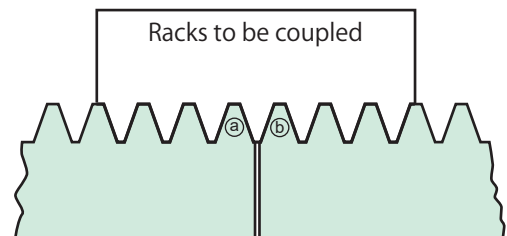



2D • 3D CAD

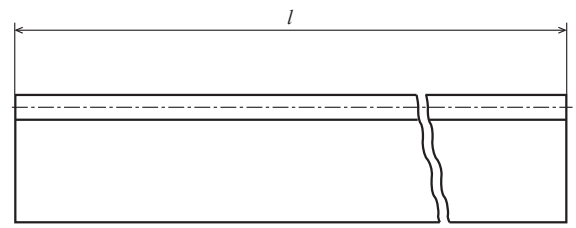
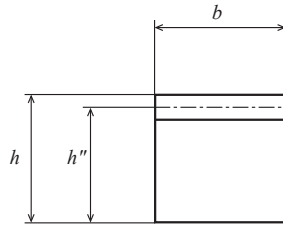

Unit: mm

Accuracy Class	Material	Pressure angle	Heat treatment	Tooth surface hardness
Not specified by JIS	S45C	20°	—	—

- ★ No surface treatment is applied. **The racks that have gone through both-end machining can be coupled with one another.**
- ★ This product is made of a drawn material, and therefore is finished to have dimensional tolerances of h12 to h13 for both the face width and height.
- ★ Straightening is done after tooth cutting, but bending may occur due to material aging.
- ★ When the teeth are treated by induction hardening, the surface hardness of this product may not increase because the drawn material has a decarbonized layer on the surface. Also be aware that the pitch may change due to distortion or bending.

Mating gear



S45C spur gear

Catalogue number	Module	Overall length	Both-end machining	Effective number of teeth	Datum line	Face width	Height	Weight
	<i>m</i>	<i>l</i>	<i>p</i>	<i>z</i>	<i>h''</i>	<i>b</i>	<i>h</i>	<i>W(kg)</i>
<b>RK1SD 3 – 1010</b>	1	303 to 306	-	94	9	10	10	0.20
<b>RK1SD 5 – 1010</b>		505 to 508	-	158	9	10	10	0.34
<b>RK1SD 10 – 1015</b>		1021.0	0.1 to 0.3	325	14	10	15	1.12
<b>RK1.5SD 3 – 1616</b>	1.5	303 to 306	-	62	14.5	16	16	0.53
<b>RK1.5SD 5 – 1216</b>		505 to 508	-	105	14.5	12	16	0.66
<b>RK1.5SD 5 – 1616</b>		503 to 506	-	105	14.5	16	16	0.90
<b>RK1.5SD 10 – 1616</b>		1008.5	0.1 to 0.3	214	14.5	16	16	1.84
<b>RK1.5SD 5 – 1620</b>		503 to 506	-	105	18.5	16	20	1.16
<b>RK1.5SD 16 – 1620</b>		1602.2	0.1 to 0.3	340	18.5	16	20	3.72
<b>RK2SD 3 – 2020</b>		2	303 to 306	-	46	18	20	20
<b>RK2SD 5 – 2020</b>	503 to 506		-	78	18	20	20	1.40
<b>RK2SD 5 – 2025</b>	501 to 506		-	78	23	20	25	1.80
<b>RK2SD 10 – 1420</b>	1005.3		0.1 to 0.3	160	18	14	20	1.95
<b>RK2SD 10 – 2020</b>	1005.3		0.1 to 0.3	160	18	20	20	2.80
<b>RK2SD 10 – 2025</b>	1005.3		0.1 to 0.3	160	23	20	25	3.63
<b>RK2SD 16 – 2025</b>	1602.2		0.1 to 0.3	255	23	20	25	5.80
<b>RK2.5SD 3 – 2525</b>	2.5	303 to 306	-	36	22.5	25	25	1.32
<b>RK2.5SD 5 – 2525</b>		503 to 506	-	62	22.5	25	25	2.20
<b>RK2.5SD 10 – 1825</b>		1005.3	0.1 to 0.4	128	22.5	18	25	3.13
<b>RK2.5SD 10 – 2525</b>		1005.3	0.1 to 0.4	128	22.5	25	25	4.40
<b>RK3SD 3 – 3030</b>	3	300 to 306	-	30	27	30	30	1.90
<b>RK3SD 5 – 3030</b>		503 to 506	-	52	27	30	30	3.20
<b>RK3SD 10 – 2230</b>		1008.5	0.1 to 0.4	107	27	22	30	4.80
<b>RK3SD 10 – 3030</b>		1008.5	0.1 to 0.4	107	27	30	30	6.40



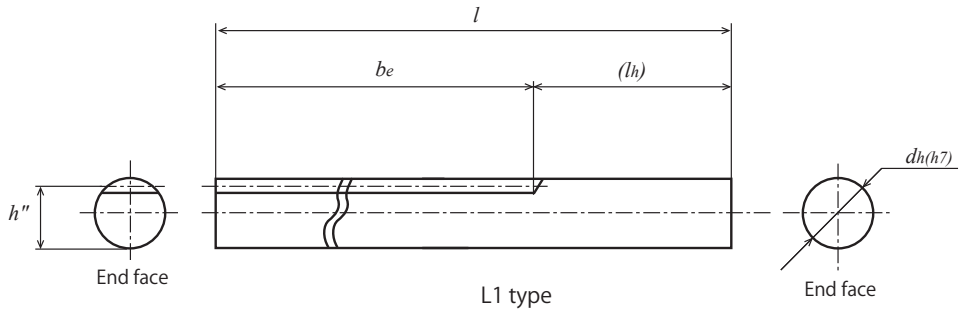

Unit: mm

Accuracy Class	Material	Pressure angle	Heat treatment	Tooth surface hardness
Not specified by JIS	SUS304	20°	—	—

Mating gear



- ★ No surface treatment is applied. This product cannot be coupled with another rack as it has not been both-end machined.
- ★ The dimensional tolerance of the material is 202 ± 1 mm when the nominal overall length is 200 mm, and 305 ± 1 mm when the nominal overall length is 300 mm.

Catalogue number	Module	Overall length	Effective number of teeth	Effective contact length	Datum line	Shaft diameter	Stem length	Weight
	<i>m</i>	<i>l</i>	<i>z</i>	<i>b<sub>e</sub></i>	<i>h''</i>	<i>d<sub>h</sub>(h7)</i>	<i>l<sub>h</sub></i>	<i>W(g)</i>
<b>ORK50SU 2 – 0815</b>	0.5	200	95	149	7.5	φ 8	50	78
<b>ORK75SU 2 – 0815</b>	0.75	200	63	148	7.25	φ 8	50	76
<b>ORK80SU 2 – 0815</b>	0.8	200	59	148	7.2	φ 8	50	76
<b>ORK1SU 3 – 1024</b>	1	300	76	238	9	φ 10	60	177

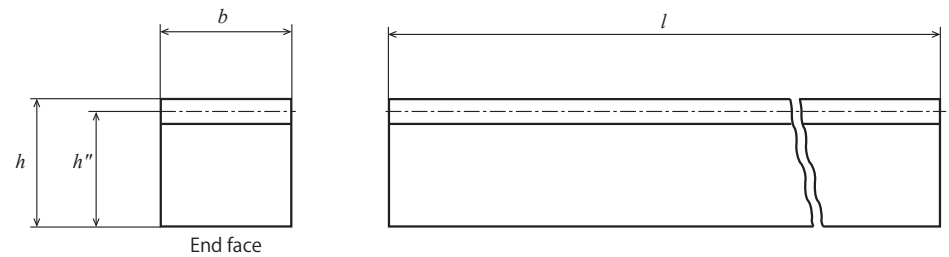

Unit: mm

Accuracy Class	Material	Pressure angle	Heat treatment	Tooth surface hardness
Not specified by JIS	SUS304	20°	—	—

Mating gear



- ★ No surface treatment is applied. **The racks that have gone through both-end machining can be coupled with one another.**
- ★ Overall length: If both-end machining is done, the overall length is obtained by subtracting 0.06 to 0.5 mm from the theoretical value.
- ★ This product is made of a drawn material, and therefore is finished to have dimensional tolerances of h12 to h13 for both the face width and height.
- ★ Straightening is done after tooth cutting, but bending may occur due to material aging.

Catalogue number	Module	Overall length	Both-end machining	Effective number of teeth	Datum line	Face width	Height	Weight
	<i>m</i>	<i>l</i>	<i>p</i>	<i>z</i>	<i>h''</i>	<i>b</i>	<i>h</i>	<i>W(g)</i>
<b>RK50SU 2 – 0310</b>	0.5	202 to 205	-	126	9.5	3	10	45
<b>RK50SU 2 – 0808</b>		202 to 205	-	126	7.5	8	8	95
<b>RK50SU 5 – 0810</b>		505 to 508	-	319	9.5	8	10	300
<b>RK75SU 2 – 0310</b>	0.75	202 to 205	-	83	9.25	3	10	44
<b>RK75SU 2 – 0808</b>		202 to 205	-	83	7.25	8	8	91
<b>RK75SU 5 – 0810</b>		505 to 508	-	212	9.25	8	10	295
<b>RK80SU 2 – 0707</b>	0.8	202 to 205	-	78	6.2	7	7	70
<b>RK80SU 5 – 0510</b>		505 to 508	-	198	9.2	5	10	183
<b>RK80SU 5 – 0710</b>		505 to 508	-	198	9.2	7	10	256
<b>RK1SU 3 – 1010</b>	1	303 to 306	-	94	9	10	10	210
<b>RK1SU 5 – 0810</b>		505 to 508	-	158	9	8	10	280
<b>RK1SU 5 – 1010</b>		505 to 508	-	158	9	10	10	360
<b>RK1.5SU 3 – 1616</b>	1.5	303 to 306	-	62	14.5	16	16	0.55(kg)
<b>RK1.5SU 5 – 1616</b>		503 to 506	-	105	14.5	16	16	0.92(kg)
<b>RK1.5SU 10 – 1616</b>		1008.5	0.1 to 0.3	214	14.5	16	16	1.83(kg)

# RK

## Rack (Brass)

Module 0.3/0.5/0.75/0.8

(Full Depth Tooth)



2D • 3D CAD

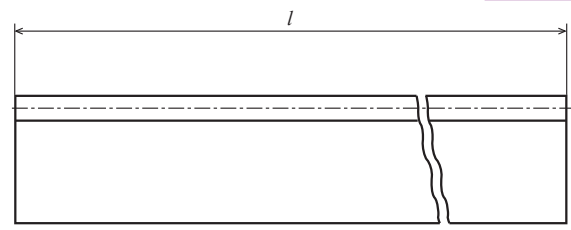
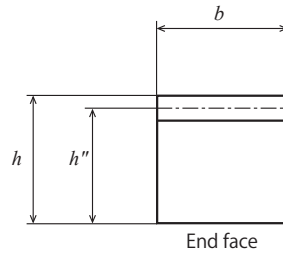
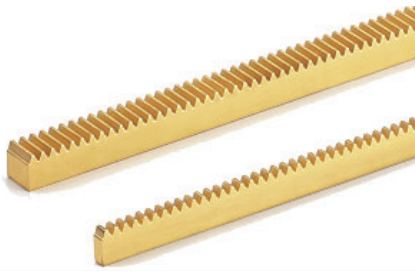

Unit: mm

Accuracy Class	Material	Pressure angle	Heat treatment	Tooth surface hardness
Not specified by JIS	C3604B	20°	—	—

Mating gear



Metallic spur gear

- ★ No surface treatment is applied. This product cannot be coupled with another rack as it has not been both-end machined.
- ★ The dimensional tolerance for the overall length of the material (200 mm and 505 mm) is 0 to +3 mm.

Catalogue number	Module	Overall length	Effective number of teeth	Datum line	Face width	Height	Weight
	<i>m</i>	<i>l</i>	<i>z</i>	<i>h''</i>	<i>b(h1l)</i>	<i>h(h1l)</i>	<i>W(g)</i>
<b>RK30B 2 – 0308</b>	0.3	200	210	7.7	3	8	38
<b>RK50B 2 – 0308</b>	0.5	200	125	7.5	3	8	37
<b>RK50B 2 – 0808</b>		200	125	7.5	8	8	98
<b>RK50B 5 – 0810</b>		505	319	9.5	8	10	313
<b>RK75B 2 – 0308</b>	0.75	200	82	7.25	3	8	35
<b>RK75B 2 – 0808</b>		200	82	7.25	8	8	95
<b>RK75B 5 – 0310</b>		505	212	9.25	3	10	115
<b>RK75B 5 – 0810</b>		505	212	9.25	8	10	307
<b>RK80B 2 – 0707</b>	0.8	200	77	6.2	7	7	70
<b>RK80B 5 – 0510</b>		505	198	9.2	5	10	191
<b>RK80B 5 – 0710</b>		505	198	9.2	7	10	268

# RK

## Rack (Blue POM)

Module 0.5/0.8/1

(Full Depth Tooth)

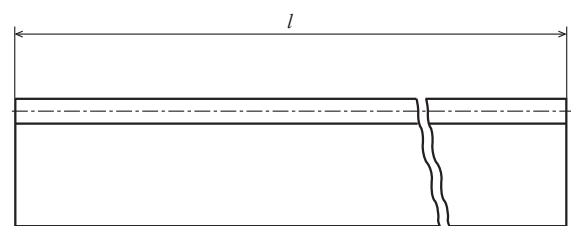
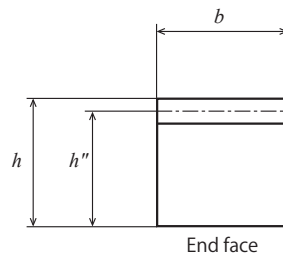

Unit: mm

Accuracy Class	Material	Pressure angle	Heat treatment	Tooth surface hardness
Not specified by JIS	Blue POM	20°	—	—

Mating gear



SG/SGR/ Blue POM Spur gear

- ★ This product cannot be coupled with another rack as it has not been both-end machined.
- ★ Straightening of bend: Straightening is done after tooth cutting, but bending may occur due to material aging or temperature changes. Straighten the bend before installation.
- ★ Because of the characteristics of the blue POM material, the dimensions change with time and due to temperature changes.
- ★ For details on blue POM, refer to P. 22.

When a polyacetal gear is meshed with a polyacetal gear, the strength is approximately 75% of that when a polyacetal gear is meshed with a metallic gear.

When a polyacetal gear is used, it is recommended to use a metallic spur gear with ground tooth surfaces as the mating gear.

Catalogue number	Module	Overall length	Effective number of teeth	Datum line	Face width	Height	Weight
	<i>m</i>	<i>l</i>	<i>z</i>	<i>h''</i>	<i>b</i>	<i>h</i>	<i>W(g)</i>
<b>RK50BP 2 – 0510</b>	0.5	202 to 205	126	9.5	5	10	13.4
<b>RK80BP 2 – 0510</b>	0.8	202 to 205	78	9.2	5	10	13.0
<b>RK80BP 5 – 0510</b>		505 to 508	198	9.2	5	10	32.6
<b>RK1BP 3 – 1010</b>	1	303 to 306	94	9	10	10	38.2
<b>RK1BP 5 – 1010</b>		502 to 506	158	9	10	10	63.7
<b>RK1BP 5 – 1012</b>		502 to 506	158	11	10	12	77.9

CONTENTS

INFORMATION

GEARBOXES

ANTI-BACKLASH SPUR GEARS

SPUR GEARS

RACKS

HELICAL GEARS AND SCREW GEARS

MITER GEARS

BEVEL GEARS

WORMS AND WORM WHEELS

REFERENCES

CONTENTS

INFORMATION

GEARBOXES

ANTI-BACKLASH  
SPUR GEARS

SPUR GEARS

**RACKS**

HELICAL GEARS AND  
SCREW GEARS

MITTER GEARS

BEVEL GEARS

WORMS AND WORM  
WHEELS

REFERENCES

Circular pitch size  
**CP Rack gears**  
**RKP series**  
**CP Pinion gears**  
**SP series**

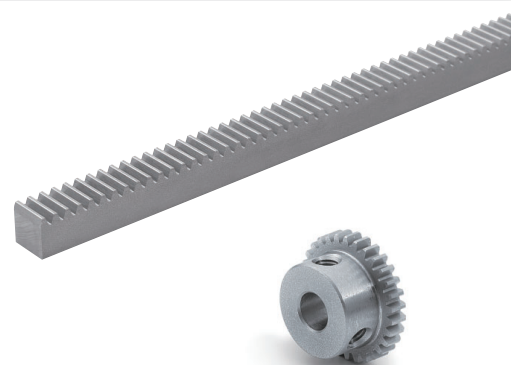

\* These are samples





### How to Read Catalogue Numbers

**RKP      5      SD      5      –      16 16**

Gear type	Pitch	Material	Overall length	Face width	Height
RKP: CP Rack gear (Circular pitch)	Represents the size of the circumferential pitch between adjacent teeth. In case of 5, the circumferential pitch is 5mm.	B : Brass C3604B SD: S45C	Unit: mm The actual length indicates a value 100 times. Example: 2 → "200mm" 3 → "300mm"	Unit: mm	Unit: mm

**SP      5      S      –      15**

Gear type	Pitch	Material	Hole finish	Number of teeth
SP: CP Pinion / Spur gear (Circular pitch)	Represents the size of the circumferential pitch between adjacent teeth. In case of 5, the circumferential pitch is 5mm. The distance per revolution is the number of teeth x 5mm.	S: S45C	Lathe turning [-]: No screw holes provided, no key grooves provided. [*]: Two screw holes provided.	Example: When the number of teeth is 15: "15"

Catalogue number	RKP	SP	RKP	SP
Shape				
Page	P. 188	P. 188	P. 189	P. 189
Material	Brass	S45C	S45C	S45C
Circular Pitch (CP)	CP2	CP2	CP5 / CP10	CP5 / CP10
Heat treatment	—	—	—	—
Teeth process sequence	Cutting	Cutting	Cutting	Cutting

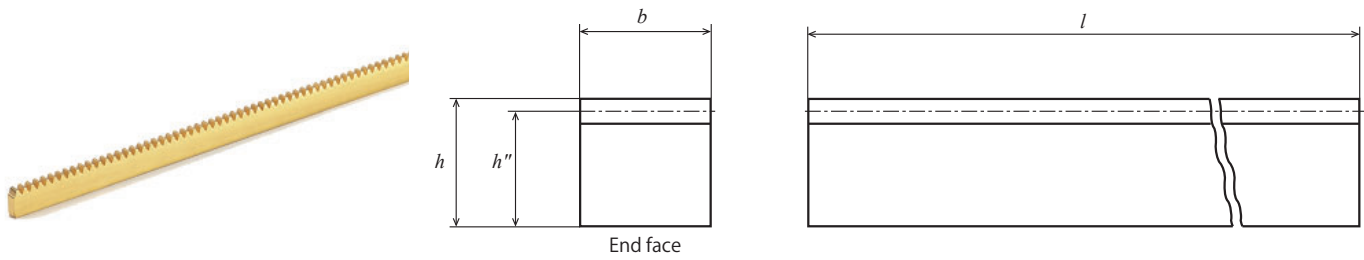

Unit: mm

Accuracy Class	Material	Pressure angle	Heat treatment	Tooth surface hardness
Not specified by JIS	C3604B	20°	—	—

- ★ No surface treatment is applied. This product cannot be coupled with another rack as it has not been both-end machined.
- ★ The dimensional tolerance for the overall length of the material (200 mm and 505 mm) is 0 to +3 mm.
- ★ The tooth size is based on the circular pitch (CP), and therefore, this product cannot be meshed with a gear with a module size.
- ★ Select the mating pinion from KG's SP Series pinions designed exclusively for CP racks.
- ★ For details such as how to calculate the rack assembly distance, refer to "Rack gear information" on the next page.

Catalogue number	Pitch	Overall length	Effective number of teeth	Datum line	Face width	Height	Weight
	<i>cp</i>	<i>l</i>	<i>z</i>	<i>h''</i>	<i>b(h11)</i>	<i>h(h11)</i>	<i>W(g)</i>
<b>RKP2B 2 - 0308</b>	2	200	98	7.36	3	8	35.8
<b>RKP2B 5 - 0310</b>		505	248	9.36	3	10	113.7

# SP

## CP Pinion (S45C)

### Pitch 2 (Module 0.6366)

### (Full Depth Tooth)

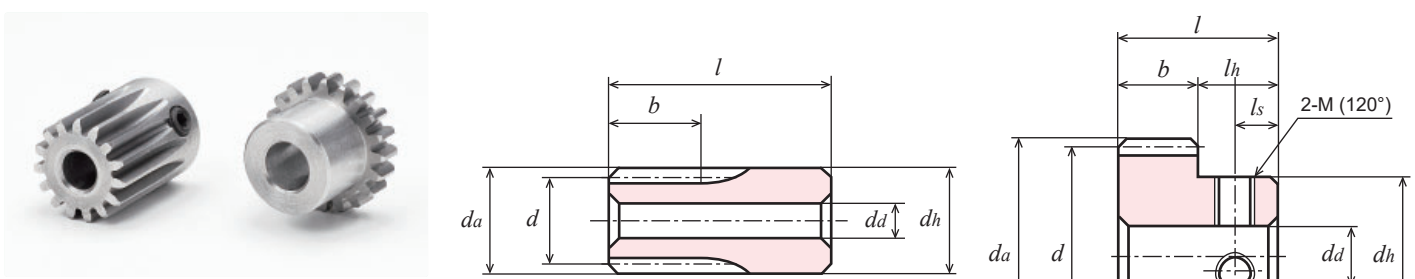

Unit: mm

Accuracy Class	Material	Pressure angle	Heat treatment	Tooth surface hardness
[JIS B 1702-1] N8	S45C	20°	—	—

- ★ No surface treatment is applied. [\*] Two screw holes and set screws are provided.
- ★ The tooth size is based on the circular pitch (CP), and therefore, this product cannot be meshed with a rack with a module size.
- ★ This allowable transfer capability table was prepared by using the formulas presented by the JGMA (Japan Gear Manufacturers Association). For the unit conversion method, refer to P. 20 in "References."
- ★ Select the mating rack from KG's RKP Series CP racks.

Catalogue number	Pitch	Number of teeth	Reference diameter	Tip diameter	Type	Face width	Hole diameter	Hub outside diameter	Hub length	Overall length	Screw		Distance per revolution	Weight
											2-M(120°)	ls		
	<i>cp</i>	<i>z</i>	<i>d</i>	<i>da</i>		<i>b</i>	<i>dd(H7)</i>	<i>dh</i>	<i>lh</i>				Note)	<i>W(g)</i>
<b>SP2S - 15</b>	2	15	φ 9.55	φ 10.82	K2	5	φ4(H8)	φ10.82	10	15	-	-	30	8.54
<b>SP2S - 20</b>		20	φ 12.73	φ 14.01	B1	3	φ 5	φ10	7	10	-	-	40	5.78
<b>SP2S * 20</b>		20	φ 12.73	φ 14.01	B1	3	φ 5	φ10	7	10	2-M3	3.5	40	5.55
<b>SP2S - 25</b>		25	φ 15.92	φ 17.19	B1	3	φ 6	φ12	7	10	-	-	50	8.67
<b>SP2S - 30</b>		30	φ 19.10	φ 20.37	B1	3	φ 6	φ15	7	10	-	-	60	14.2
<b>SP2S * 30</b>		30	φ 19.10	φ 20.37	B1	3	φ 6	φ15	7	10	2-M4	3.5	60	13.5

Catalogue number	Allowable transfer capability for different revolutions per minute Bending strength (Unit: W)						
	10rpm	100rpm	200rpm	400rpm	800rpm	1,200rpm	1,500rpm
<b>SP2S - 15</b>	0.88	8.78	17.55	35.10	70.21	105.31	131.64
<b>SP2S - 20</b>	0.83	8.25	16.50	33.00	66.01	99.01	117.89
<b>SP2S - 25</b>	1.14	11.36	22.71	45.43	90.86	131.38	154.87
<b>SP2S - 30</b>	1.46	14.56	29.12	58.25	116.49	162.56	189.99

Catalogue number	Allowable transfer capability for different revolutions per minute Surface durability (Unit: W)						
	10rpm	100rpm	200rpm	400rpm	800rpm	1,200rpm	1,500rpm
<b>SP2S - 15</b>	0.03	0.29	0.59	1.21	2.42	3.63	4.54
<b>SP2S - 20</b>	0.03	0.33	0.66	1.32	2.63	3.95	4.81
<b>SP2S - 25</b>	0.05	0.53	1.05	2.10	4.27	6.19	7.34
<b>SP2S - 30</b>	0.08	0.77	1.55	3.10	6.27	8.76	10.41



2D • 3D CAD

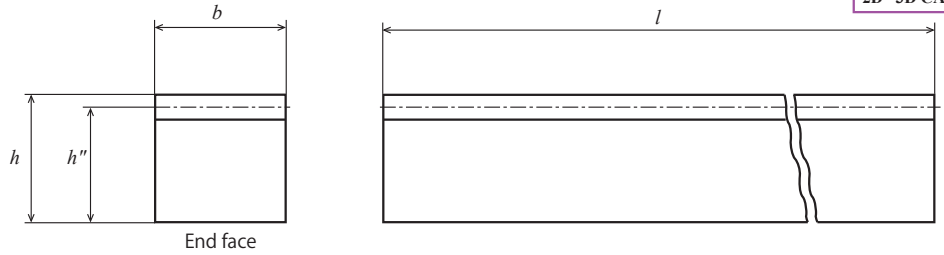

Unit: mm

Accuracy Class	Material	Pressure angle	Heat treatment	Tooth surface hardness
Not specified by JIS	S45C	20°	—	—

- ★ No surface treatment is applied. The racks (ex. length 1,000mm) that have gone through both-end machining can be coupled with one another.
- ★ The tooth size is based on the circular pitch (CP), and therefore, this product cannot be meshed with a gear with a module size.
- ★ Select the mating pinion from KG' s SP Series pinions designed exclusively for CP racks.
- ★ For details such as how to calculate the rack assembly distance, refer to "Rack gear information" on the next page.
- ★ This product is made of a drawn material, and therefore is finished to have dimensional tolerances of h11 to h12 for both the face width and height.

Catalogue number	Pitch	Overall length	Both-end machining	Effective number of teeth	Datum line	Face width	Height	Weight
	<i>cp</i>	<i>l</i>	<i>p</i>	<i>z</i>	<i>h''</i>	<i>b</i>	<i>h</i>	<i>W(kg)</i>
<b>RKP5SD 5 – 1616</b>	5	503 to 506	-	98	14.41	16	16	0.92
<b>RKP5SD 10 – 1616</b>	5	1,000	0.1 to 0.3	200	14.41	16	16	1.80
<b>RKP10SD 10 – 3030</b>	10	1,000	0.1 to 0.4	100	26.82	30	30	6.32

# SP

## CP Pinion (S45C)

Pitch 5 (Module 1.5915) / 10 (Module 3.1831) (Full Depth Tooth)

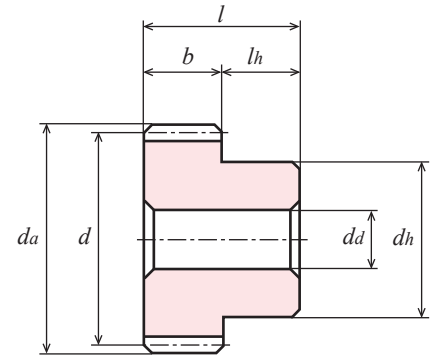

Unit: mm

Accuracy Class	Material	Pressure angle	Heat treatment	Tooth surface hardness
[JIS B 1702-1] N8	S45C	20°	—	—

- ★ No surface treatment is applied.
- ★ The tooth size is based on the circular pitch (CP), and therefore, this product cannot be meshed with a rack with a module size.
- ★ This allowable transfer capability table was prepared by using the formulas presented by the JGMA (Japan Gear Manufacturers Association). For the unit conversion method, refer to P. 20 in "References."
- ★ Select the mating rack from KG' s RKP Series CP racks.

Catalogue number	Pitch	Number of teeth	Reference diameter	Tip diameter	Type	Face width	Hole diameter	Hub outside diameter	Hub length	Overall length	Distance per revolution	Weight
	<i>cp</i>	<i>z</i>	<i>d</i>	<i>da</i>		<i>b</i>	<i>da(H7)</i>	<i>dh</i>	<i>lh</i>	<i>l</i>	Note)	<i>W(g)</i>
<b>SP5S – 15</b>	5	15	φ23.87	φ 27.06	B1	16	φ 8	φ18	10	26	75	65.9
<b>SP5S – 20</b>		20	φ31.83	φ 35.01	B1	16	φ10	φ25	10	26	100	122.4
<b>SP5S – 24</b>		24	φ38.20	φ 41.38	B1	16	φ10	φ25	10	26	120	166.3
<b>SP10S – 20</b>	10	20	φ63.66	φ 70.03	B1	30	φ18	φ50	15	45	200	0.89(kg)
<b>SP10S – 30</b>		30	φ95.49	φ101.86	B1	30	φ18	φ60	15	45	300	1.93(kg)

Catalogue number	Allowable transfer capability for different revolutions per minute Bending strength (Unit: W)						
	10rpm	100rpm	200rpm	400rpm	800rpm	1,200rpm	1,500rpm
<b>SP5S – 15</b>	17.55	175.51	351.03	702.06	1353.35	1861.80	2149.14
<b>SP5S – 20</b>	27.51	275.13	550.27	1048.12	2000.97	2695.23	3134.46
<b>SP5S – 24</b>	35.75	357.55	715.09	1312.09	2487.24	3300.42	3972.78
<b>SP10S – 20</b>	206.4	2063.5	3751.8	6603.2	12537.7	17687.1	21265.0
<b>SP10S – 30</b>	364.1	3509.2	5944.2	10787.6	20804.7	29453.5	36408.2

Catalogue number	Allowable transfer capability for different revolutions per minute Surface durability (Unit: W)						
	10rpm	100rpm	200rpm	400rpm	800rpm	1,200rpm	1,500rpm
<b>SP5S – 15</b>	0.65	6.55	13.21	26.63	51.62	71.99	84.51
<b>SP5S – 20</b>	1.20	12.03	24.28	46.78	89.93	123.79	147.26
<b>SP5S – 24</b>	1.76	17.69	35.76	66.51	127.17	173.46	213.09
<b>SP10S – 20</b>	9.67	97.83	181.2	327.2	632.5	932.7	1169.8
<b>SP10S – 30</b>	22.78	223.3	389.8	732.0	1458.7	2192.2	2850.5

# Rack gear information

CONTENTS

INFORMATION

GEARBOXES

ANTI-BACKLASH  
SPUR GEARS

SPUR GEARS

RACKS

HELICAL GEARS AND  
SCREW GEARS

MITER GEARS

BEVEL GEARS

WORMS AND WORM  
WHEELS

REFERENCES

## How to calculate the rack assembly distance

For gears whose size is based on the circular pitch, their size can be converted to a module size by dividing the circular pitch by pi.

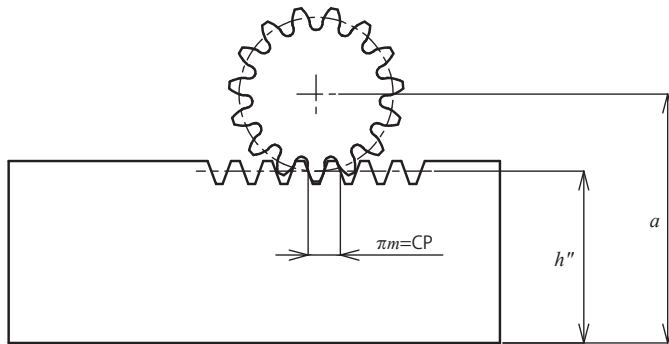

$$a = h'' + \frac{m \times z}{2} + xm$$

Explanation

- $a$  : Assembly distance (distance from the rack bottom to the spur gear center)
- $h''$  : Rack datum line
- $m$  : Module
- $z$  : Number of teeth

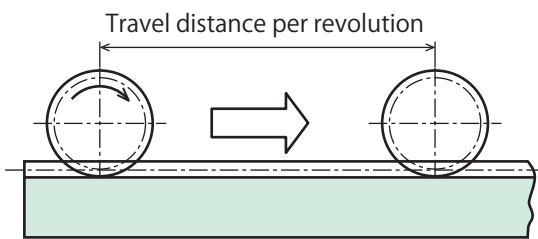

Note) Travel distance per revolution ... Distance that a pinion travels when it rotates once on a rack

## How to couple racks

When coupling multiple racks, align their pitch by using another rack as shown in the figure to the right in order to set the optimal pitch between racks ① and ②.

Note: We do not offer racks designed exclusively for coupling.

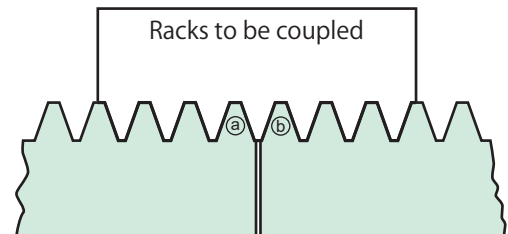

# Helical gears

# Screw gears

## H series



\* These are samples

### How to Read Catalogue Numbers

**H 1 S 13 R - B**

Gear type	Module	Material	Number of teeth	Hand of helix	Hole finish	Shape
H: Helical gear	Represents the module size. Example: When the module is 1: "1"	S : S45C SU: Stainless steel SUS304 BP: Acetal Blue POM D : Acetal White POM	Example: When the number of teeth is 15: "15"	R: Right hand helix L: Left hand helix	Lathe turning [-]: No screw holes provided, no key grooves provided. [*]: Two screw holes provided.	B: Hub provided on one side

Catalogue number	H	H	H	H
Shape				
Page	P. 194	P. 196	P. 198	P. 202
Material	S45C	SUS304	Blue POM	White POM
Module	m1 to 3	m1 to 1.5	m1 to 3	m1 to 1.5
Accuracy grade	JIS Class N9	JIS Class N9	JIS Class N9 to N10 *	JIS Class N9 to N10 *
Teeth process sequence	Induction hardening after cutting	Cutting	Cutting	Cutting

※ Accuracy at the time of manufacture.



# Helical gear information

## 1. Cautions on Assembly

### 1) Shaft angle:

The hands of helix of the gears to be coupled depends on the shaft angle.

- In case of helical gears with the shaft twisted  $90^\circ$  : Combine gears with the same hand of helix.
- In case of helical gears with the shaft parallel: Combine gears with different hands of helix.

To achieve ideal intermeshing, install each helical gear at as accurate a shaft angle as possible.

When the shafts are parallel, low noise and high strength can be expected with a high contact ratio.

### 2) Thrust load on helical gears:

Helical gears provide smoother intermeshing than spur gears but have the disadvantage of generating a thrust load in the axial direction because they have helical teeth. Therefore, the bearings must be designed so that they can adequately support the axial thrust load.

A failure could occur if this product is used with a product other than ours.

If your device is designed with specifications other than our standard ones, consult with us.

## 2. Thrust Load Applied to a Helical Gear in the Axial Direction

In case of helical gears with the shaft twisted  $90^\circ$  : Combine gears with the same hand of helix.

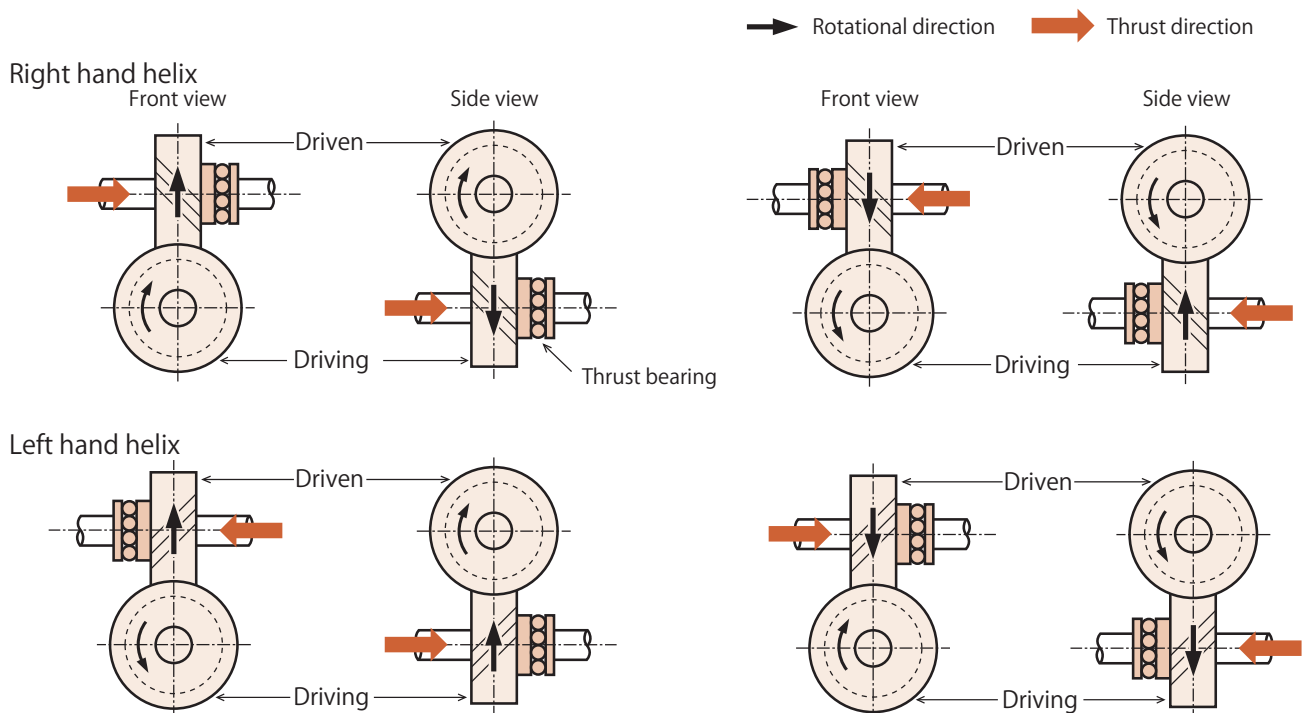

In case of helical gears with the shaft parallel: Combine gears with different hands of helix.

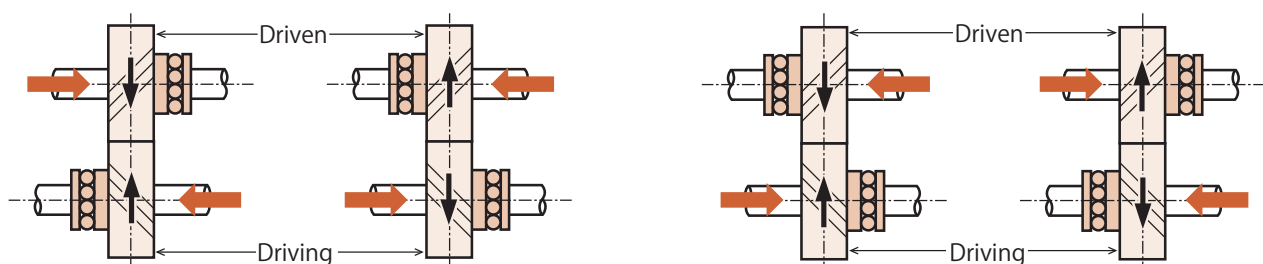

# Helical gear information

## 3. Relationship between hand of helix and assembly

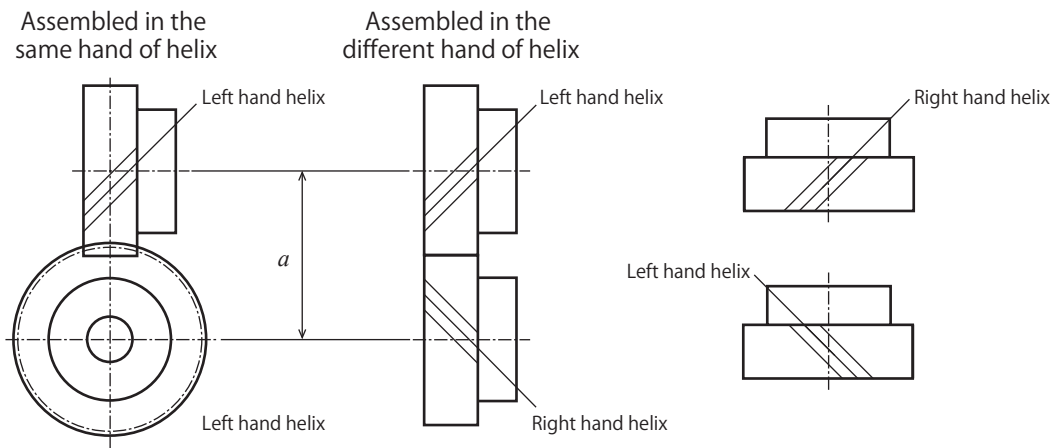

# H: Hardened

## Helical Gear/Screw Gear (S45C)

Normal Module 1/1.5/2/2.5/3

(Full Depth Tooth)



Unit: mm

Accuracy Class	Material	Pressure angle	Helix angle	Heat treatment	Tooth surface hardness	Backlash ①
[JIS B 1702-1] N9	S45C	20°	45°	Induction hardening of teeth	HRC47 to 53	See the table below

★ No surface treatment is applied.

★ This allowable transfer capability table was prepared by using the formulas presented by the JGMA (Japan Gear Manufacturers Association). For the unit conversion method, refer to P. 20 in "References."

★ Assembly method and allowable transfer capability: When gears are assembled with the shafts parallel, check the allowable transfer capability table. In this case, the teeth have surface contact. When gears are assembled with the shafts intersecting, the allowable transfer capability is significantly lower than when they are assembled with the shafts parallel. In this case, the teeth have point contact.

① This is a theoretical value obtained when a pair of gears of the same type and material are meshed with each other. The backlash is a circumferential backlash.

Catalogue number	Hand of helix	Module	Number of teeth	Reference diameter	Tip diameter	Face width	Hole diameter	Hub diameter	Hub length	Overall length	Weight
		<i>m</i>									
<b>H1S 13R — B</b>	R	1	13	φ 18.38	φ 20.4	12	φ 8	φ15	10	22	0.03
<b>H1S 13L — B</b>	L	1	13	φ 18.38	φ 20.4	12	φ 8	φ15	10	22	0.03
<b>H1S 26R — B</b>	R	1	26	φ 36.77	φ 38.8	12	φ10	φ32	10	22	0.15
<b>H1S 26L — B</b>	L	1	26	φ 36.77	φ 38.8	12	φ10	φ32	10	22	0.15
<b>H1.5S 13R — B</b>	R	1.5	13	φ 27.58	φ 30.6	15	φ10	φ23	10	25	0.09
<b>H1.5S 13L — B</b>	L	1.5	13	φ 27.58	φ 30.6	15	φ10	φ23	10	25	0.09
<b>H1.5S 26R — B</b>	R	1.5	26	φ 55.15	φ 58.2	15	φ12	φ40	10	25	0.36
<b>H1.5S 26L — B</b>	L	1.5	26	φ 55.15	φ 58.2	15	φ12	φ40	10	25	0.36
<b>H2S 13R — B</b>	R	2	13	φ 36.77	φ 40.8	20	φ12	φ30	13	33	0.21
<b>H2S 13L — B</b>	L	2	13	φ 36.77	φ 40.8	20	φ12	φ30	13	33	0.21
<b>H2S 26R — B</b>	R	2	26	φ 73.54	φ 77.5	20	φ16	φ55	13	33	0.86
<b>H2S 26L — B</b>	L	2	26	φ 73.54	φ 77.5	20	φ16	φ55	13	33	0.86
<b>H2.5S 13R — B</b>	R	2.5	13	φ 45.96	φ 50.9	22	φ14	φ38	14	36	0.37
<b>H2.5S 13L — B</b>	L	2.5	13	φ 45.96	φ 50.9	22	φ14	φ38	14	36	0.37
<b>H2.5S 26R — B</b>	R	2.5	26	φ 91.92	φ 96.9	22	φ18	φ63	14	36	1.41
<b>H3S 13R — B</b>	R	3	13	φ 55.15	φ 61.2	25	φ16	φ44	15	40	0.58
<b>H3S 26L — B</b>	L	3	26	φ110.31	φ116.3	25	φ22	φ70	15	40	2.21

CONTENTS

INFORMATION

GEARBOXES

ANTI-BACKLASH  
SPUR GEARS

SPUR GEARS

RACKS

HELICAL GEARS AND  
SCREW GEARS

MITER GEARS

BEVEL GEARS

WORMS AND WORM  
WHEELS

REFERENCES



2D • 3D CAD

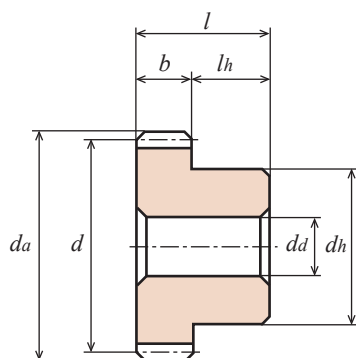

B1 type [-]

Allowable transfer capability for different revolutions per minute (for parallel shafts) Bending strength (Unit: kW)							Allowable transfer capability for different revolutions per minute (for parallel shafts) Surface durability (Unit: kW)							Backlash of parallel shafts (Unit: mm)	Catalogue number
10 rpm	100 rpm	200 rpm	400 rpm	800 rpm	1,200 rpm	1,500 rpm	10 rpm	100 rpm	200 rpm	400 rpm	800 rpm	1,200 rpm	1,500 rpm		
0.009	0.09	0.19	0.38	0.77	1.13	1.36	0.003	0.03	0.07	0.14	0.28	0.42	0.51	0.04 to 0.10	H1S 13R – B H1S 13L – B
0.022	0.22	0.45	0.90	1.67	2.26	2.64	0.015	0.15	0.31	0.64	1.20	1.65	1.95	0.04 to 0.10	H1S 26R – B H1S 26L – B
0.027	0.27	0.54	1.08	2.12	2.94	3.47	0.010	0.10	0.20	0.41	0.81	1.14	1.36	0.06 to 0.15	H1.5S 13R – B H1.5S 13L – B
0.063	0.63	1.27	2.48	4.25	5.76	6.98	0.045	0.45	0.91	1.81	3.16	4.37	5.35	0.06 to 0.15	H1.5S 26R – B H1.5S 26L – B
0.06	0.64	1.29	2.58	4.77	6.47	7.54	0.02	0.24	0.49	0.99	1.87	2.57	3.03	0.08 to 0.20	H2S 13R – B H2S 13L – B
0.15	1.50	2.99	5.53	9.17	12.99	15.73	0.11	1.07	2.16	4.06	6.91	9.98	12.23	0.08 to 0.20	H2S 26R – B H2S 26L – B
0.11	1.10	2.21	4.41	7.75	10.31	12.43	0.04	0.52	0.85	1.71	3.06	4.14	5.04	0.10 to 0.25	H2.5S 13R – B H2.5S 13L – B
0.26	2.57	5.15	9.04	15.34	21.67	26.20	0.19	1.87	3.79	6.78	11.83	17.08	20.92	0.10 to 0.25	H2.5S 26R – B
0.18	1.82	3.63	7.10	12.14	16.47	19.93	0.07	0.71	1.42	2.82	4.92	6.79	8.31	0.12 to 0.30	H3S 13R – B
0.42	4.22	8.24	14.10	24.43	34.56	42.17	0.31	3.11	6.15	10.75	19.22	27.82	34.40	0.12 to 0.30	H3S 26L – B

# H

## Helical Gear/Screw Gear (SUS304)

Normal Module 1/1.5

(Full Depth Tooth)



Unit: mm

Accuracy Class	Material	Pressure angle	Helix angle	Heat treatment	Tooth surface hardness	Backlash ①
[JIS B 1702-1] N9	SUS304	20°	45°	—	—	See the table below

★ No surface treatment is applied.

★ This allowable transfer capability table was prepared by using the formulas presented by the JGMA (Japan Gear Manufacturers Association). For the unit conversion method, refer to P. 20 in "References."

★ Assembly method and allowable transfer capability: When gears are assembled with the shafts parallel, check the allowable transfer capability table. In this case, the teeth have surface contact. When gears are assembled with the twisted axes, the allowable transfer capability is significantly lower than when they are assembled with the shafts parallel. In this case, the teeth have point contact.

① This is a theoretical value obtained when a pair of gears of the same type and material are meshed with each other. The backlash is a circumferential backlash.

Catalogue number	Hand of helix	Module	Number of teeth	Reference diameter	Tip diameter	Face width	Hole diameter	Hub diameter	Hub length	Overall length	Weight
		<i>m</i>	<i>z</i>	<i>d</i>	<i>d<sub>a</sub></i>	<i>b</i>	<i>d<sub>a</sub>(H8)</i>	<i>d<sub>h</sub></i>	<i>l<sub>h</sub></i>	<i>l</i>	<i>W(g)</i>
<b>H1SU 13R — B</b>	R	1	13	φ18.38	φ20.4	12	φ 8	φ15	10	22	30.5
<b>H1SU 13L — B</b>	L	1	13	φ18.38	φ20.4	12	φ 8	φ15	10	22	30.5
<b>H1SU 26R — B</b>	R	1	26	φ36.77	φ38.8	12	φ10	φ32	10	22	151.1
<b>H1.5SU 13R — B</b>	R	1.5	13	φ27.58	φ30.6	15	φ10	φ23	10	25	88.4
<b>H1.5SU 26R — B</b>	R	1.5	26	φ55.15	φ58.2	15	φ12	φ40	10	25	361.4

For gears with a [\*], two tap holes have been drilled. No set screws are provided for the SUS304 products.

Catalogue number	Hand of helix	Module	Number of teeth	Reference diameter	Tip diameter	Face width	Hole diameter	Hub diameter	Hub length	Overall length	Screw		Weight
											<i>2-M(120°)</i>	<i>l<sub>s</sub></i>	
<b>H1.5SU 13R * B</b>	R	1.5	13	φ27.58	φ30.6	15	φ10	φ23	10	25	2-M4	5	87.4



2D • 3D CAD

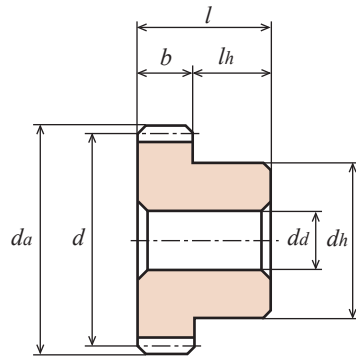

B1 type [-]

Allowable transfer capability for different revolutions per minute (for parallel shafts), Bending strength (Unit: W)							Backlash of parallel shafts (Unit: mm)	Catalogue number
10rpm	100rpm	200rpm	400rpm	800rpm	1,200rpm	1,500rpm		
4.07	40.68	81.36	162.73	325.46	477.08	572.13	0.06 to 0.12	<b>H1SU 13R – B</b> <b>H1SU 13L – B</b>
9.50	95.02	190.03	380.06	703.15	952.90	1,110.70	0.06 to 0.12	<b>H1SU 26R – B</b>
11.44	114.42	228.83	457.67	894.52	1,237.04	1,460.79	0.09 to 0.18	<b>H1.5SU 13R – B</b>
26.72	267.23	534.46	1,044.61	1,786.69	2,423.37	2,933.19	0.09 to 0.18	<b>H1.5SU 26R – B</b>

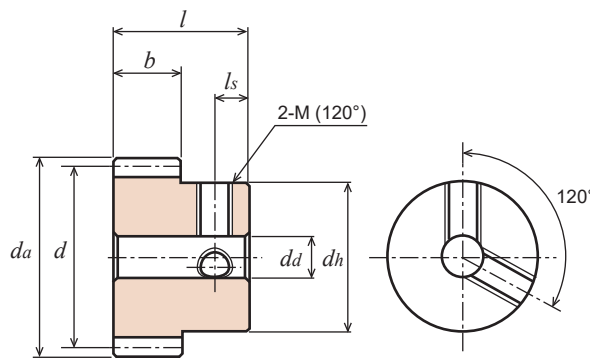

B1 type [\*]

Allowable transfer capability for different revolutions per minute (for parallel shafts), Bending strength (Unit: W)							Backlash of parallel shafts (Unit: mm)	Catalogue number
10rpm	100rpm	200rpm	400rpm	800rpm	1,200rpm	1,500rpm		
11.44	114.42	228.83	457.67	894.52	1,237.04	1,460.79	0.09 to 0.18	<b>H1.5SU 13R * B</b>

# H

## Helical Gear/Screw Gear (Blue POM)

Normal Module 1/1.5/2

(Full Depth Tooth)



Unit: mm

Accuracy Class ②	Material	Pressure angle	Helix angle	Heat treatment	Tooth surface hardness	Backlash ①
[JIS B 1702-1] N9 to N10	Blue POM	20°	45°	—	—	See the table below

★ This allowable transfer capability table was prepared by using the Lewis formula. For the unit conversion method, refer to P. 20 in "References."

★ Assembly method and allowable transfer capability: When gears are assembled with the twisted axes, check the allowable transfer capability table. In this case, the teeth have point contact.

★ Because of the material characteristics, the dimensions and accuracy change with time and due to temperature changes.

★ For details on blue POM, refer to P. 22.

① This is a theoretical value obtained when a pair of gears of the same type and material are meshed with each other.

② Accuracy at the time of manufacture. The backlash is a circumferential backlash.

Catalogue number	Hand of helix	Module	Number of teeth	Reference diameter	Tip diameter	Face width	Hole diameter	Hub diameter	Hub length	Overall length	Weight
		<i>m</i>		<i>d</i>	<i>d<sub>a</sub></i>		<i>d<sub>a</sub></i>	<i>d<sub>h</sub></i>			
H1BP 10R — B	R	1	10	φ14.14	φ16.1	12	φ 4	φ10	10	22	3.4
H1BP 10L — B	L	1	10	φ14.14	φ16.1	12	φ 4	φ10	10	22	3.4
H1BP 13R — B	R	1	13	φ18.38	φ20.4	12	φ 5	φ14	10	22	6.0
H1BP 13L — B	L	1	13	φ18.38	φ20.4	12	φ 5	φ14	10	22	6.0
H1BP 15R — B	R	1	15	φ21.21	φ23.2	12	φ 6	φ15	10	22	7.6
H1BP 15L — B	L	1	15	φ21.21	φ23.2	12	φ 6	φ15	10	22	7.6
H1BP 20R — B	R	1	20	φ28.28	φ30.3	12	φ 6	φ22	10	22	15.1
H1BP 20L — B	L	1	20	φ28.28	φ30.3	12	φ 6	φ22	10	22	15.1
H1BP 26R — B	R	1	26	φ36.77	φ38.8	12	φ 8	φ32	10	22	27.7
H1BP 26L — B	L	1	26	φ36.77	φ38.8	12	φ 8	φ32	10	22	27.7
H1.5BP 10R — B	R	1.5	10	φ21.21	φ24.2	15	φ 6	φ16	10	25	9.3
H1.5BP 10L — B	L	1.5	10	φ21.21	φ24.2	15	φ 6	φ16	10	25	9.3
H1.5BP 13R — B	R	1.5	13	φ27.58	φ30.6	15	φ 8	φ23	10	25	16.6
H1.5BP 13L — B	L	1.5	13	φ27.58	φ30.6	15	φ 8	φ23	10	25	16.6
H1.5BP 15R — B	R	1.5	15	φ31.82	φ34.8	15	φ 8	φ25	10	25	22.0
H1.5BP 15L — B	L	1.5	15	φ31.82	φ34.8	15	φ 8	φ25	10	25	22.0
H1.5BP 20R — B	R	1.5	20	φ42.43	φ45.4	15	φ10	φ30	10	25	37.1
H1.5BP 20L — B	L	1.5	20	φ42.43	φ45.4	15	φ10	φ30	10	25	37.1
H1.5BP 26R — B	R	1.5	26	φ55.15	φ58.2	15	φ10	φ40	10	25	65.5
H1.5BP 26L — B	L	1.5	26	φ55.15	φ58.2	15	φ10	φ40	10	25	65.5
H2BP 10R — B	R	2	10	φ28.28	φ32.3	20	φ10	φ22	15	35	21.9
H2BP 10L — B	L	2	10	φ28.28	φ32.3	20	φ10	φ22	15	35	21.9
H2BP 13R — B	R	2	13	φ36.77	φ40.8	20	φ10	φ30	15	35	41.0
H2BP 13L — B	L	2	13	φ36.77	φ40.8	20	φ10	φ30	15	35	41.0
H2BP 15R — B	R	2	15	φ42.43	φ46.4	20	φ10	φ35	15	35	56.3
H2BP 15L — B	L	2	15	φ42.43	φ46.4	20	φ10	φ35	15	35	56.3
H2BP 20R — B	R	2	20	φ56.57	φ60.6	20	φ12	φ45	15	35	98.9
H2BP 20L — B	L	2	20	φ56.57	φ60.6	20	φ12	φ45	15	35	98.9
H2BP 26R — B	R	2	26	φ73.54	φ77.5	20	φ12	φ55	15	35	164.4
H2BP 26L — B	L	2	26	φ73.54	φ77.5	20	φ12	φ55	15	35	164.4



2D • 3D CAD

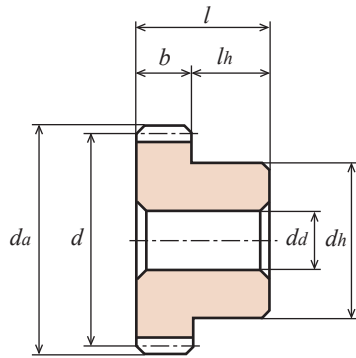

B1 type [-]

Allowable transfer capability for different revolutions per minute for helical gears with twisted axes Surface durability (Unit: W)							Backlash of parallel shafts (Unit: mm)	Catalogue number
10rpm	100rpm	200rpm	400rpm	800rpm	1,200rpm	1,500rpm		
0.06	0.51	1.03	2.05	3.29	3.70	4.62	0.06 to 0.12	H1BP 10R – B H1BP 10L – B
0.13	1.23	2.47	4.11	6.57	8.63	9.24	0.06 to 0.12	H1BP 13R – B H1BP 13L – B
0.21	1.95	3.70	6.16	9.86	12.32	13.86	0.06 to 0.12	H1BP 15R – B H1BP 15L – B
0.50	4.62	8.42	14.38	22.18	27.11	29.27	0.06 to 0.12	H1BP 20R – B H1BP 20L – B
1.10	9.86	17.46	28.75	42.72	50.52	53.91	0.06 to 0.12	H1BP 26R – B H1BP 26L – B
0.21	1.95	3.70	6.16	9.86	12.32	13.86	0.09 to 0.18	H1.5BP 10R – B H1.5BP 10L – B
0.46	4.11	7.80	13.14	20.54	24.65	27.73	0.09 to 0.18	H1.5BP 13R – B H1.5BP 13L – B
0.72	6.47	11.71	19.72	29.58	35.74	38.51	0.09 to 0.18	H1.5BP 15R – B H1.5BP 15L – B
1.69	14.89	26.08	42.31	60.79	71.47	77.02	0.09 to 0.18	H1.5BP 20R – B H1.5BP 20L – B
3.71	31.42	53.81	83.39	115.01	130.62	138.63	0.09 to 0.18	H1.5BP 26R – B H1.5BP 26L – B
0.50	4.62	8.42	14.38	22.18	27.11	29.27	0.12 to 0.24	H2BP 10R – B H2BP 10L – B
1.10	9.86	17.46	28.75	42.72	50.52	53.91	0.12 to 0.24	H2BP 13R – B H2BP 13L – B
1.69	14.89	26.08	42.31	60.79	71.47	77.02	0.12 to 0.24	H2BP 15R – B H2BP 15L – B
4.00	33.79	57.51	88.73	121.59	139.25	147.87	0.12 to 0.24	H2BP 20R – B H2BP 20L – B
8.74	70.55	116.25	171.70	225.92	251.39	264.94	0.12 to 0.24	H2BP 26R – B H2BP 26L – B



# H

## Helical Gear/Screw Gear (Blue POM)

Normal Module 2.5/3

(Full Depth Tooth)



Unit: mm

Accuracy Class ②	Material	Pressure angle	Helix angle	Heat treatment	Tooth surface hardness	Backlash ①
[JIS B 1702-1] N9 to N10	Blue POM	20°	45°	—	—	See the table below

★ This allowable transfer capability table was prepared by using the Lewis formula. For the unit conversion method, refer to P. 20 in "References."

★ Assembly method and allowable transfer capability: When gears are assembled with the twisted axes, check the allowable transfer capability table. In this case, the teeth have point contact.

★ Because of the material characteristics, the dimensions and accuracy change with time and due to temperature changes.

★ For details on blue POM, refer to P. 22.

① This is a theoretical value obtained when a pair of gears of the same type and material are meshed with each other.

② Accuracy at the time of manufacture. The backlash is a circumferential backlash.

Catalogue number	Hand of helix	Module	Number of teeth	Reference diameter	Tip diameter	Face width	Hole diameter	Hub diameter	Hub length	Overall length	Weight
		<i>m</i>	<i>z</i>	<i>d</i>	<i>d<sub>a</sub></i>	<i>b</i>	<i>d<sub>d</sub></i>	<i>d<sub>h</sub></i>	<i>l<sub>h</sub></i>	<i>l</i>	<i>W(g)</i>
<b>H2.5BP 10R — B</b>	R	2.5	10	φ 35.36	φ 40.4	22	φ10	φ26	16	38	38.2
<b>H2.5BP 10L — B</b>	L	2.5	10	φ 35.36	φ 40.4	22	φ10	φ26	16	38	38.2
<b>H2.5BP 13R — B</b>	R	2.5	13	φ 45.96	φ 50.9	22	φ12	φ38	16	38	71.0
<b>H2.5BP 13L — B</b>	L	2.5	13	φ 45.96	φ 50.9	22	φ12	φ38	16	38	71.0
<b>H2.5BP 15R — B</b>	R	2.5	15	φ 53.03	φ 58.0	22	φ12	φ40	16	38	90.8
<b>H2.5BP 15L — B</b>	L	2.5	15	φ 53.03	φ 58.0	22	φ12	φ40	16	38	90.8
<b>H2.5BP 20R — B</b>	R	2.5	20	φ 70.71	φ 75.7	22	φ12	φ60	16	38	179.5
<b>H2.5BP 20L — B</b>	L	2.5	20	φ 70.71	φ 75.7	22	φ12	φ60	16	38	179.5
<b>H2.5BP 26R — B</b>	R	2.5	26	φ 91.92	φ 96.9	22	φ16	φ70	16	38	281.9
<b>H2.5BP 26L — B</b>	L	2.5	26	φ 91.92	φ 96.9	22	φ16	φ70	16	38	281.9
<b>H3BP 10R — B</b>	R	3	10	φ 42.43	φ 48.4	25	φ12	φ34	18	43	66.0
<b>H3BP 10L — B</b>	L	3	10	φ 42.43	φ 48.4	25	φ12	φ34	18	43	66.0
<b>H3BP 13R — B</b>	R	3	13	φ 55.15	φ 61.2	25	φ15	φ45	18	43	113.8
<b>H3BP 13L — B</b>	L	3	13	φ 55.15	φ 61.2	25	φ15	φ45	18	43	113.8
<b>H3BP 15R — B</b>	R	3	15	φ 63.64	φ 69.6	25	φ15	φ50	18	43	151.2
<b>H3BP 15L — B</b>	L	3	15	φ 63.64	φ 69.6	25	φ15	φ50	18	43	151.2
<b>H3BP 20R — B</b>	R	3	20	φ 84.85	φ 90.9	25	φ15	φ60	18	43	260.3
<b>H3BP 20L — B</b>	L	3	20	φ 84.85	φ 90.9	25	φ15	φ60	18	43	260.3
<b>H3BP 26R — B</b>	R	3	26	φ110.31	φ116.3	25	φ18	φ80	18	43	449.0
<b>H3BP 26L — B</b>	L	3	26	φ110.31	φ116.3	25	φ18	φ80	18	43	449.0



2D • 3D CAD

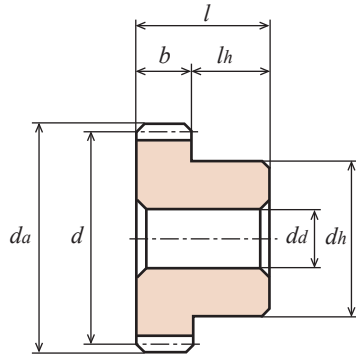

B1 type [-]

Allowable transfer capability for different revolutions per minute for helical gears with twisted axes Surface durability (Unit: W)							Backlash of parallel shafts (Unit: mm)	Catalogue number
10rpm	100rpm	200rpm	400rpm	800rpm	1,200rpm	1,500rpm		
0.98	8.73	15.81	25.88	38.61	45.60	49.29	0.15 to 0.3	H2.5BP 10R – B H2.5BP 10L – B
2.15	18.69	32.66	52.17	73.94	86.26	92.42	0.15 to 0.3	H2.5BP 13R – B H2.5BP 13L – B
3.30	28.14	48.27	75.17	104.33	119.53	127.85	0.15 to 0.3	H2.5BP 15R – B H2.5BP 15L – B
7.77	63.26	104.74	155.68	206.20	230.44	241.84	0.15 to 0.3	H2.5BP 20R – B H2.5BP 20L – B
16.96	130.83	208.67	296.98	376.26	414.05	429.76	0.15 to 0.3	H2.5BP 26R – B H2.5BP 26L – B
1.69	14.89	26.08	42.31	60.79	71.47	77.02	0.18 to 0.36	H3BP 10R – B H3BP 10L – B
3.71	31.42	53.81	83.39	115.01	130.62	138.63	0.18 to 0.36	H3BP 13R – B H3BP 13L – B
5.68	47.03	79.07	119.53	161.02	182.38	192.55	0.18 to 0.36	H3BP 15R – B H3BP 15L – B
13.37	104.95	169.44	244.40	313.82	346.27	361.98	0.18 to 0.36	H3BP 20R – B H3BP 20L – B
29.12	215.24	333.54	460.05	567.67	616.14	637.71	0.18 to 0.36	H3BP 26R – B H3BP 26L – B

# H

## Helical Gear/Screw Gear (White POM)

Normal Module 1/1.5

(Full Depth Tooth)



Unit: mm

Accuracy Class ②	Material	Pressure angle	Helix angle	Heat treatment	Tooth surface hardness	Backlash ①
[JIS B 1702-1] N9 to N10	White POM	20°	45°	—	—	See the table below

★ This allowable transfer capability table was prepared by using the Lewis formula. For the unit conversion method, refer to P. 20 in "References."

★ Assembly method and allowable transfer capability: When gears are assembled with the shafts parallel, check the allowable transfer capability table. In this case, the teeth have surface contact. When gears are assembled with the twisted axes, the allowable transfer capability is significantly lower than when they are assembled with the shafts parallel. In this case, the teeth have point contact.

★ Because of the material characteristics, the dimensions and accuracy change with time and due to temperature changes.

① This is a theoretical value obtained when a pair of gears of the same type and material are meshed with each other.

② Accuracy at the time of manufacture. The backlash is a circumferential backlash.

Catalogue number	Hand of helix	Module <i>m</i>	Number of teeth <i>z</i>	Reference diameter <i>d</i>	Tip diameter <i>d<sub>a</sub></i>	Face width <i>b</i>	Hole diameter <i>d<sub>d</sub></i>	Hub diameter <i>d<sub>h</sub></i>	Hub length <i>l<sub>h</sub></i>	Overall length <i>l</i>	Weight <i>W(g)</i>
<b>H1D 13R — B</b>	R	1	13	φ18.38	φ20.4	12	φ 8	φ15	10	22	5.4
<b>H1D 13L — B</b>	L	1	13	φ18.38	φ20.4	12	φ 8	φ15	10	22	5.4
<b>H1D 26R — B</b>	R	1	26	φ36.77	φ38.8	12	φ10	φ32	10	22	26.9
<b>H1D 26L — B</b>	L	1	26	φ36.77	φ38.8	12	φ10	φ32	10	22	26.9
<b>H1.5D 13R — B</b>	R	1.5	13	φ27.58	φ30.6	15	φ10	φ23	10	25	15.7
<b>H1.5D 13L — B</b>	L	1.5	13	φ27.58	φ30.6	15	φ10	φ23	10	25	15.7

For gears with a [\*], two tap holes have been drilled. Also, two set screws are provided.

Catalogue number	Hand of helix	Module <i>m</i>	Number of teeth <i>z</i>	Reference diameter <i>d</i>	Tip diameter <i>d<sub>a</sub></i>	Face width <i>b</i>	Hole diameter <i>d<sub>d</sub></i>	Hub diameter <i>d<sub>h</sub></i>	Hub length <i>l<sub>h</sub></i>	Overall length <i>l</i>	Screw		Weight <i>W(g)</i>
											2-M(120°)	l <sub>s</sub>	
<b>H1.5D 13R * B</b>	R	1.5	13	φ27.58	φ30.6	15	φ10	φ23	10	25	2-M4	5	15.5

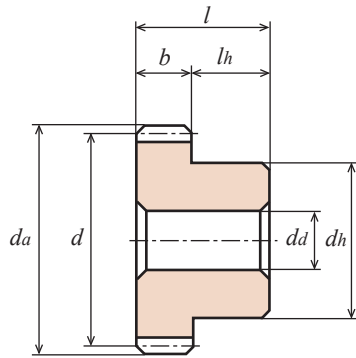

B1 type [-]

Allowable transfer capability for different revolutions per minute (for parallel shafts), Bending strength (Unit: W)							Backlash of parallel shafts (Unit: mm)	Catalogue number
10rpm	100rpm	200rpm	400rpm	800rpm	1,200rpm	1,500rpm		
2.98	29.75	59.46	118.79	237.06	354.80	442.76	0.06 to 0.12	H1D 13R – B H1D 13L – B
5.95	59.46	118.79	237.06	472.02	704.88	875.19	0.06 to 0.12	H1D 26R – B H1D 26L – B
4.71	47.10	94.12	187.93	374.61	560.04	698.30	0.09 to 0.18	H1.5D 13R – B H1.5D 13L – B

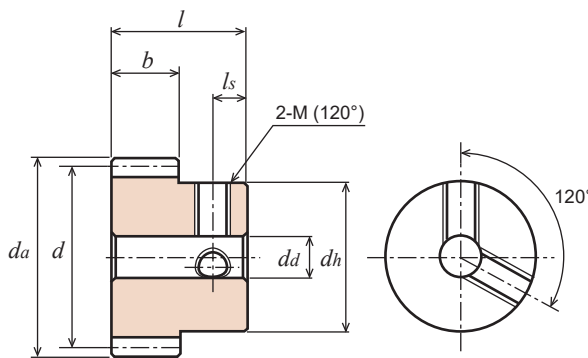

B1 type [\*]

Allowable transfer capability for different revolutions per minute (for parallel shafts), Bending strength (Unit: W)							Backlash of parallel shafts (Unit: mm)	Catalogue number
10rpm	100rpm	200rpm	400rpm	800rpm	1,200rpm	1,500rpm		
4.71	47.10	94.12	187.93	374.61	560.04	698.30	0.09 to 0.18	H1.5D 13R * B

# Memo

CONTENTS

INFORMATION

GEARBOXES

ANTI-BACKLASH  
SPUR GEARS

SPUR GEARS

RACKS

HELICAL GEARS AND  
SCREW GEARS

MITTER GEARS

BEVEL GEARS

WORMS AND WORM  
WHEELS

REFERENCES

# Ground miter gears

## Miter gears

MG series  
MGE series  
M series

MGH series  
ML series  
ML-N series



\* These are samples.

### How to read catalogue numbers

**MG 1.5 S 20 R – 30 08 H**

Gear type	Module	Material	Number of teeth	Tooth trace shape	Hole finish	Assembly distance	Hole diameter	Type
MG : Ground spiral miter gear (Accuracy grade: JIS Class 1) MGE: Ground spiral miter gear (Accuracy grade: JIS Class 2) ML : B-LOCK miter gear M : Miter gear	Represents the module size. When the module is less than 1, the figure indicates a value 100 times the actual module size. Example: Module 0.5 → "50" Module 0.8 → "80"	MG Series S: SCM440  MGE Series S: SCM435, 440  ML and M Series S : S45C B : Brass C3604B SU : Stainless steel SUS304 SUM: Stainless steel SUS304L BP : Acetal Blue POM D : Acetal White POM	Example: When the number of teeth is 20: "20"	Blank : Straight R : Right-hand spiral L : Left-hand spiral	MG and MGE Series Ground finish [-]: No screw holes provided, no key grooves provided [=]: Key groove provided  ML and M Series Lathe turning finish [-]: No screw holes provided, no key grooves provided [+]: One screw hole provided [*]: Two screw holes provided [=]: Key groove provided [#]: One key groove and one screw hole provided	Unit: mm	Unit: mm	H: Induction hardening of teeth HB: Induction hardening of teeth + Black oxide finish

**MGH R + 8**

#### Features of the MGH Series

The teeth have been treated by induction hardening, and the holes have been finished by grinding. Also, keys and set screws are provided. Therefore, the MGH Series can be used without additional machining. [Note] For details on modules, refer to the respective product description pages.

Gear type	Tooth trace shape	Hole finish	Hub length
MGH: Miter gear	Blank :Straight R :Right-hand spiral L :Left-hand spiral	Grinding finish [+]: One screw hole provided [=]: Key groove provided	Unit: mm

Catalogue number	MG	MGE	M	M	M	MGH
Shape						
Page	P. 212	P. 214	P. 216	P. 218	P. 220	P. 222
Material	SCM440	SCM435・440	S45C	S45C	S45C	S45C
Module	m1.5 to 3	m1.5 to 3	m0.8 to 3	m1 to 3	m1 to 3	m1 to 2
Tooth trace shape	Spiral	Spiral	Spiral	Spiral	Spiral	Spiral
Accuracy grade	JIS Class 1	JIS Class 2	JIS Class 3	JIS Class 4	JIS Class 4	JIS Class 4
Teeth process sequence	Grinding after Induction hardening	Grinding after Induction hardening	Cutting	Induction hardening & black oxide after cutting	Induction hardening after cutting	Induction hardening after cutting

Catalogue number	ML-N	ML	M	M	MGH	M
Shape						
Page	P. 224	P. 224	P. 226	P. 228	P. 230	P. 232
Material	S45C	SUS304	S45C	S45C	S45C	SUS304
Module	m1 to 2.5	m0.8 to 2	m0.5 to 4	m1.5 to 4	m2.5 to 3	m0.8 to 3
Tooth trace shape	Straight	Straight	Straight	Straight	Straight	Straight
Accuracy grade	JIS Class 3	JIS Class 4	JIS Class 3	JIS Class 4	JIS Class 4	JIS Class 4
Teeth process sequence	Cutting	Cutting	Cutting	Induction hardening after cutting	Induction hardening after cutting	Cutting

Catalogue number	M	M	M	M
Shape				
Page	P. 232	P. 234	P. 234	P. 236
Material	SUS304L	Brass	White POM	Blue POM
Module	m0.5 to 1	m0.5 to 1	m 1	m 0.8 to 3
Tooth trace shape	Straight	Straight	Straight	Straight
Accuracy grade	—	JIS Class 4	—	—
Teeth process sequence	MIM (metal injection molding)	Cutting	Cutting	Cutting

# Miter gear information

## 1. What are Miter Gears?

### 1) Miter gears and bevel gears

Among our standard bevel gears, those with a gear ratio (pinion shaft P : gear shaft G) of 1:1 are referred to as miter gears.

Gear ratio (P : G)	Miter gears	Bevel gears					
		1: 1.5		1: 2		1: 3	
Pitch angle	45°	Pinion	33° 41'	Pinion	26° 34'	Pinion	18° 26'
		Gear	56° 19'	Gear	63° 26'	Gear	71° 34'
Shaft angle	90°						

### 2) Differences between straight miter gears and spiral miter gears

	Tooth trace	Tooth surface grinding	High-speed rotation	Circumferential velocity of pitch circle*	Contact ratio	Rotation smoothness	Thrust
Straight miter gears	Linear	Not possible	○	Less than 5.5 m/s	Low	○	Small
Spiral miter gears	Curved	Possible	◎	5.5 m/s or more <u>When the velocity is 15 m/s or more, use of a ground gear is recommended.</u>	High	◎	Large

$$* \text{Circumferential velocity [m/s]} = \frac{\pi \times \text{Reference diameter [mm]} \times \text{Revolutions per minute [rpm]}}{1000 \times 60}$$

- Spiral miter gear:
- ① Low noise can be expected with a high contact ratio.
  - ② Right-hand and left-hand gears can be combined.

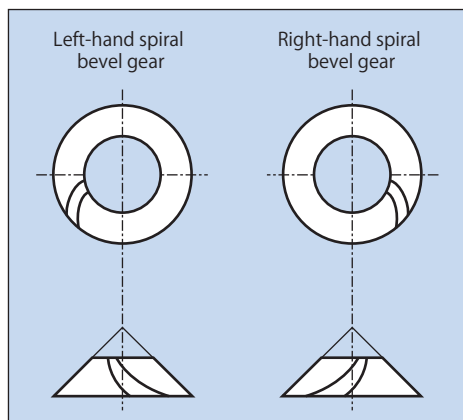

Left hand



Right hand

# Miter gear information

## 2. Cautions on Assembly

### 1) Installation

Particular attention is required when installing miter gears. In general, miter gears have a bearing only on one side and their shafts bend easily when subjected to a load, which is one of their main disadvantages. This results in poor, uneven tooth contact. Make sure that the gear shafts and bearings have adequate toughness and the bearings are located close to the gears. Assemble miter gears so that they can be adjusted in the axial direction and insert a shim into the hub end face. This enables easy adjustment of the tooth contact.

### 2) Mating gear

This product cannot be used with other companies' products. If your device is designed with a product other than the standard products, use our customization service. Use a ground gear with a ground gear, and a cut gear with a cut gear.

### 3) Lubrication

Select an appropriate lubrication method according to the revolutions per minute and load conditions. For details, refer to "Lubrication of Gears" in "References."

### 4) Gear shafts and backlash

To achieve ideal intermeshing, assemble gears at as accurate a shaft angle as possible with an appropriate backlash. For both ground gears and cut gears, the recommended shaft angle and shaft center height misalignment are  $\pm 15'$  and  $\pm 0.015$  mm or less, respectively.

Backlash: Our products are designed to have the backlash shown in Table 1 when the gears are assembled with the assembly distance given in the catalogue.

For details, refer to "How to Measure the Backlash" in "References."

Thrust acting on spiral miter gears

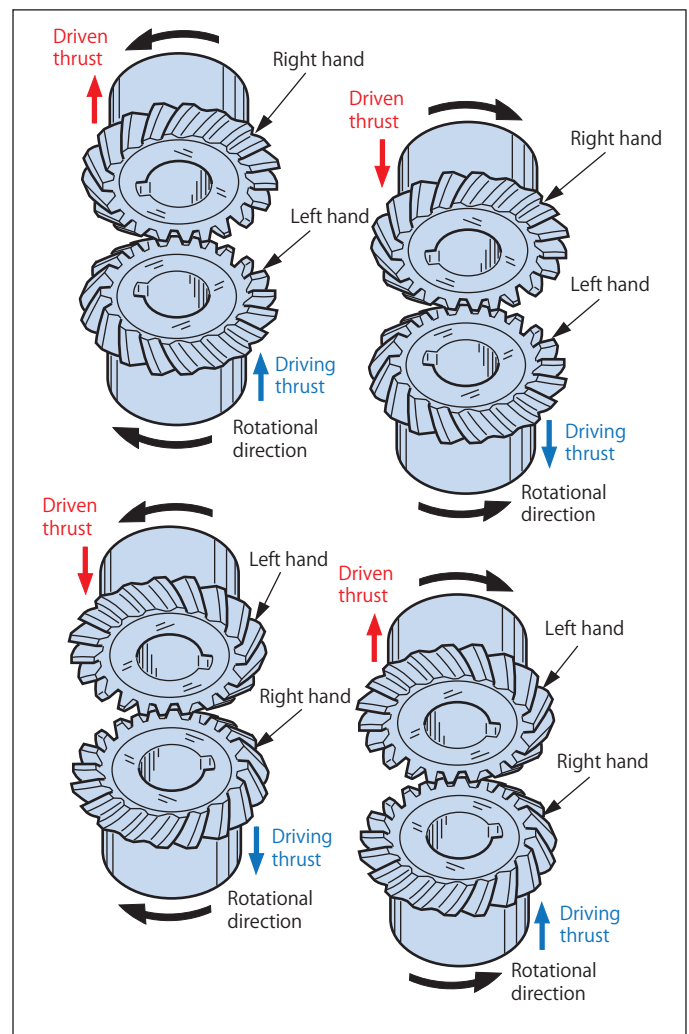

Table 1 Backlash of miter gears (when a pair of gears are meshed, same for straight and spiral miter gears)

Backlash of ground miter gears

Module	Backlash [mm]
	SCM440
m =1.5	0.03 to 0.06
m =2	0.04 to 0.08
m =2.5	0.05 to 0.1
m =3	0.06 to 0.12

Backlash of cut miter gears

Module	Backlash [ mm ]	
	SCM435 · 440, S45C, SUS304, C3604B	White/blue POM
m ≤ 0.9	0.02 to 0.08	0.03 to 0.10
More than 0.9 and 2 or less	0.05 to 0.12	0.05 to 0.16
More than 2 and 4 or less	0.06 to 0.15	-
More than 4 and 6 or less	0.08 to 0.20	-

- Adjustment: The assembly distance, backlash, and tooth contact can easily be adjusted by inserting a shim in the hub end face.
- Change in circumferential backlash (when a miter gear is moved in the axial direction)  
 Straight miter gear:  $J_t = J_x \times 0.51$   
 Spiral miter gear:  $J_t = J_x \times 0.63$

$J_t$ : Change in circumferential backlash

$J_x$ : Axial displacement

\* The backlash may not be as estimated depending on machining or assembly accuracy.



# Miter gear information

## Features of Ground Spiral Miter Gears (MG Series)

Accuracy grade	Hardening	Tooth surface finish	Grinding areas	Module	Gear ratio	Backlash	High-speed rotation	Noise	Tooth surface hardness
JIS B 1704 Class 1	Induction hardening	Grinding	Hole diameter Hub lateral face Hub circumference Tooth tip circumference Tooth lateral face	$m = 1.5$ $2.0$ $2.5$ $3.0$	$u = 1:1$	Settable to up to $30 \mu\text{m}$	◎	Low	HRC52 to 60

\* Do not mesh a ground gear with a cut gear.

### Cautions on additional machining for ground spiral miter gears

- 1) The hub circumference and tooth tip circumference have been finished by grinding to ensure adequate accuracy and workability at the time of additional machining by customers.  
(The tooth tip circumference has been chamfered parallel to the shaft center, which enables accurate chucking.)  
For the cautions on additional machining, refer to Fig. 1 and "Precautions for additional processing" in this catalogue.
- 2) Be sure to use a soft jaw and scroll chuck. Adjust the runout of the product to as close to zero as possible.  
(The runout should be 0.003 mm or less.)

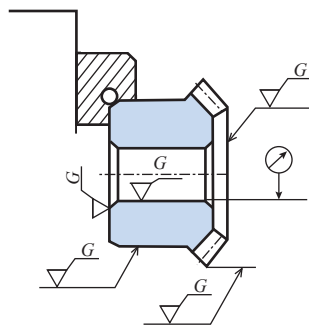

The hub circumference and end faces have been finished by grinding for high-accuracy additional machining.

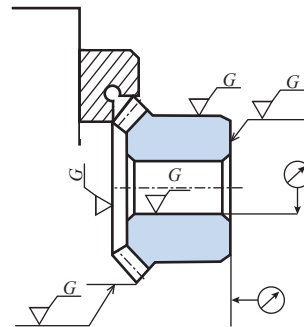

The tooth tip circumference and end faces have been finished by grinding for high-accuracy additional machining.

Fig. 1 Additional machining

# Miter gear information

## Features of Ground Spiral Miter Gears (MGE Series)

Accuracy grade	Hardening	Tooth surface finish*	Grinding areas	Module	Gear ratio	Backlash	High-speed rotation	Noise	Tooth surface hardness	Cost balance
JIS B 1704 Class 2	Induction hardening	Grinding	Hole diameter Hub lateral face	m = 1.5 2.0 2.5 3.0	u = 1:1	Refer to the respective product description pages.	○	Low	HRC49 to 55	Good

### 1) Design focused on size reduction

(1) Number of teeth: 19 and 23. Optimal for compact designs.

(2) The bearing and oil seal specifications have been taken into consideration.

Compared with conventional spiral miter gears with 20 or 25 teeth, this product enables further size reduction including design around the gears, such as the bearing size.

### 2) Assembly example

In general, a gearbox is assembled by assembling a gear unit (gear, bearing, shaft, etc.) in advance and passing it through the hole in the bearing housing.

Therefore, as shown in Fig. 2, the outside diameter of the gear unit must be smaller than the outside diameter of the bearing or oil seal.

Dimensional conditions

(Outside diameter of gear)  $\approx$  (Diameter of pitch circle)  $A = (1 + r)$  mm or more

(Diameter of bearing  $D$ )  $\geq$  (Outside diameter of gear) + (2  $\times$  A)

The table below shows the bearing and oil seal specifications assuming the above conditions when the number of teeth is 19 and 20 for reference.

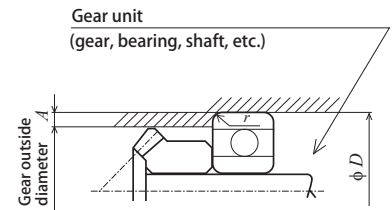

Fig. 2 Bearing housing

Table Gear outside diameter, bearing diameter, and oil seal diameter

m	Number of teeth	Gear outside diameter	Shaft diameter	Bearing diameter		Oil seal diameter	m	Number of teeth	Gear outside diameter	Shaft diameter	Bearing diameter		Oil seal diameter
				$\phi D$	r						$\phi D$	r	
1.5	19	$\phi 28.5$	$\phi 12$	$\phi 32$	0.6	$\phi 32$	2.5	19	$\phi 47.5$	$\phi 20$	$\phi 52$	1.1	—
			$\phi 15$	$\phi 32$	0.3	$\phi 32$				$\phi 25$	$\phi 52$	1.0	$\phi 52$
	20	$\phi 30.0$	$\phi 12$	$\phi 37$	1.0	—		20	$\phi 50.0$	$\phi 20$	—	—	—
			$\phi 15$	$\phi 35$	0.6	$\phi 35$				$\phi 25$	$\phi 62$	1.1	—
2.0	19	$\phi 38.0$	$\phi 15$	$\phi 42$	1.0	—	3.0	19	$\phi 57.0$	$\phi 25$	$\phi 62$	1.1	—
			$\phi 20$	$\phi 42$	0.6	$\phi 42$				$\phi 28$	$\phi 68$	1.1	—
	20	$\phi 40.0$	$\phi 15$	—	—	—		20	$\phi 60.0$	$\phi 25$	—	—	—
			$\phi 20$	$\phi 47$	1.0	$\phi 47$				$\phi 28$	$\phi 68$	1.1	—

This table indicates the values when the outside diameter of the gear is used as the diameter of the pitch circle.

- CONTENTS
- INFORMATION
- GEARBOXES
- ANTI-BACKLASH SPUR GEARS
- SPUR GEARS
- RACKS
- HELICAL GEARS AND SCREW GEARS
- MITER GEARS
- BEVEL GEARS
- WORMS AND WORM WHEELS
- REFERENCES

# Miter gear information

## Features of B-LOCK Miter Gears (ML Series and the new ML-N Series)

This product has the following features with the boss fastening mechanism:

Method of fastening with shaft	Damage to shaft	Tuning of intermeshing	Machining of shaft (key groove, D-shape cutting, etc.)
Friction fastening	Little	Optimal	Not required



This product is designed to be compatible with our standard straight miter gears, so it can be used as the mating gears of the standard gears.

### 1) How to adjust the backlash

B-LOCK uses a fastening mechanism at the boss of the gear to secure the gear and shaft, which, unlike when they are secured with screws, prevents the shaft from being dented.

In general, adjust the backlash by following the steps below:

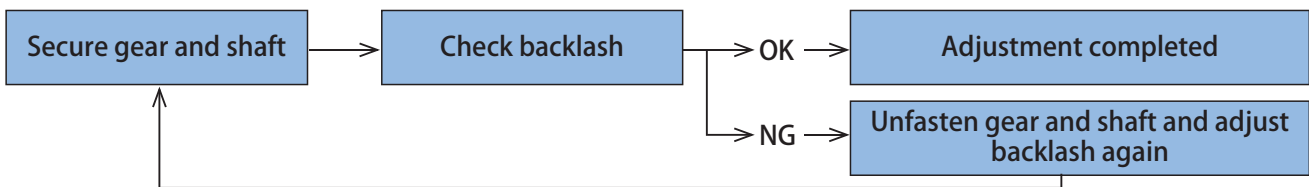

### 2) Cautions

- (1) Selection:** Select a product whose maximum operating torque is less than or equal to the torque value given in the allowable transfer capability table. To prevent accidents, take the motor startup torque into consideration.
- (2) Accuracy of the shaft to be installed:** Use a shaft whose shaft diameter tolerance is h7 or more and surface roughness is Ra1.6 (6.3 S) or more.
- (3) Warm-up operation at low load:** Avoid high-load operation immediately after assembly. Perform warm-up operation at low load to check the operation, and then, perform operation at the actual operating load. After warm-up operation at low load, tighten the set screws again to the specified torque with a torque wrench.
- (4) Additional machining and heat treatment:** Perform additional machining and heat treatment to the extent not affecting the tightening force.  
Do not perform additional machining or heat treatment for the hole length, hole diameter, and hub diameter.
- (5) If the number of startups is large:** We recommend using a product with a key groove, except for B-LOCK miter gears.
- (6) When the gear spins out:** Be sure to inspect and clean other mechanical components.  
The teeth may be damaged when the gears are disengaged. Also, broken pieces may adversely affect other mechanical components.

Please note that this product is subject to dimensional changes without prior notice to the extent not adversely affecting its functionality.

### 3) Cautions on installing gears

- To fasten the boss, use bolts with a JIS strength class of 10.9 or higher.
- Checking the tightening torque and preventing loose set screws
  - Applying a screw locking agent to the threaded portions of the screws is recommended.
  - When tightening a set screw, tighten it to the specified torque using a torque wrench.

CONTENTS

INFORMATION

GEARBOXES

ANTI-BACKLASH  
SPUR GEARS

SPUR GEARS

RACKS

HELICAL GEARS AND  
SCREW GEARS

**MITER GEARS**

BEVEL GEARS

WORMS AND WORM  
WHEELS

REFERENCES



Unit: mm

Accuracy Class	Material	Pressure angle	Helix angle	Heat treatment	Tooth surface hardness	Backlash ①
[JIS B 1704] 1	SCM440	20°	35°	Induction hardening of teeth	HRC52 to 60	See the table below.

★ No surface treatment is applied.

★ The allowable transfer capability table was prepared based on the assumption that a left-hand gear is used on the input side.

★ This allowable transfer capability table was prepared by using the formulas presented by the JGMA (Japan Gear Manufacturers Association). For the unit conversion method, refer to P. 20 in "References."

★ The values in parentheses below "Tip diameter  $d_a$ " are theoretical values. The actual maximum diameter is the value obtained after the teeth are chamfered parallel to the shaft center.

① This is a theoretical value obtained when a pair of gears of the same type and material are meshed with each other.

Catalogue number	Gear ratio	Number of teeth	Reference diameter	Tip diameter	Assembly distance	Hole diameter	Hub diameter	Hub length	Hole length	Overall length	Distance from end face to tip	Face width	Tip angle	Counterbore diameter (Reference value)	Weight
MG1.5S 20R – 3008H	1 : 1	20	$\phi 30$	$\phi 30.5$ ( $\phi 31.92$ )	30	$\phi 8$	$\phi 26$	13	19	21.11	15.96	8	50°08'	$\phi 15.37$	74.4
MG1.5S 20L – 3008H		20	$\phi 30$	$\phi 30.5$ ( $\phi 31.92$ )	30	$\phi 8$	$\phi 26$	13	19	21.11	15.96	8	50°08'	$\phi 15.37$	74.4
MG1.5S 25R – 3410H		25	$\phi 37.5$	$\phi 38$ ( $\phi 39.43$ )	34	$\phi 10$	$\phi 32$	12.5	19	22.1	16.21	9	49°18'	$\phi 19.54$	118.2
MG1.5S 25L – 3410H		25	$\phi 37.5$	$\phi 38$ ( $\phi 39.43$ )	34	$\phi 10$	$\phi 32$	12.5	19	22.1	16.21	9	49°18'	$\phi 19.54$	118.2
MG1.5S 30R – 4310H		30	$\phi 45$	$\phi 45.2$ ( $\phi 46.81$ )	43	$\phi 10$	$\phi 40$	18	25	28.13	21.41	10	47°48'	$\phi 25.72$	240.6
MG1.5S 30L – 4310H		30	$\phi 45$	$\phi 45.2$ ( $\phi 46.81$ )	43	$\phi 10$	$\phi 40$	18	25	28.13	21.41	10	47°48'	$\phi 25.72$	240.6
MG2S 20R – 3712H		20	$\phi 40$	$\phi 41$ ( $\phi 42.53$ )	37	$\phi 12$	$\phi 35$	14.5	22	24.71	18.27	10	50°04'	$\phi 21.72$	152.3
MG2S 20L – 3712H		20	$\phi 40$	$\phi 41$ ( $\phi 42.53$ )	37	$\phi 12$	$\phi 35$	14.5	22	24.71	18.27	10	50°04'	$\phi 21.72$	152.3
MG2S 25R – 4012H		25	$\phi 50$	$\phi 51$ ( $\phi 52.58$ )	40	$\phi 12$	$\phi 44$	12	20	24.12	16.29	12	49°25'	$\phi 26.06$	238.4
MG2S 25L – 4012H		25	$\phi 50$	$\phi 51$ ( $\phi 52.58$ )	40	$\phi 12$	$\phi 44$	12	20	24.12	16.29	12	49°25'	$\phi 26.06$	238.4
MG2S 30R – 5012H		30	$\phi 60$	$\phi 60.8$ ( $\phi 62.41$ )	50	$\phi 12$	$\phi 52$	16	25	29.12	21.21	12	47°52'	$\phi 36.06$	427.8
MG2S 30L – 5012H		30	$\phi 60$	$\phi 60.8$ ( $\phi 62.41$ )	50	$\phi 12$	$\phi 52$	16	25	29.12	21.21	12	47°52'	$\phi 36.06$	427.8
MG2.5S 20R – 4814H		20	$\phi 50$	$\phi 51.5$ ( $\phi 53.22$ )	48	$\phi 14$	$\phi 44$	20	29	32.28	24.61	12	50°32'	$\phi 28.06$	321.2
MG2.5S 20L – 4814H		20	$\phi 50$	$\phi 51.5$ ( $\phi 53.22$ )	48	$\phi 14$	$\phi 44$	20	29	32.28	24.61	12	50°32'	$\phi 28.06$	321.2
MG2.5S 25R – 5016H		25	$\phi 62.5$	$\phi 64$ ( $\phi 65.61$ )	50	$\phi 16$	$\phi 54$	14.5	26	30.21	20.31	15	48°49'	$\phi 34.57$	456.8
MG2.5S 25L – 5016H		25	$\phi 62.5$	$\phi 64$ ( $\phi 65.61$ )	50	$\phi 16$	$\phi 54$	14.5	26	30.21	20.31	15	48°49'	$\phi 34.57$	456.8
MG2.5S 30R – 6216H		30	$\phi 75$	$\phi 76.5$ ( $\phi 78.03$ )	62	$\phi 16$	$\phi 66$	20	32	36.08	26.01	15	47°56'	$\phi 47.57$	848.3
MG2.5S 30L – 6216H		30	$\phi 75$	$\phi 76.5$ ( $\phi 78.03$ )	62	$\phi 16$	$\phi 66$	20	32	36.08	26.01	15	47°56'	$\phi 47.57$	848.3
MG3S 20R – 5816H		20	$\phi 60$	$\phi 62$ ( $\phi 63.8$ )	58	$\phi 16$	$\phi 52$	24	35	39.57	29.9	15	50°04'	$\phi 31.57$	556.1
MG3S 20L – 5816H		20	$\phi 60$	$\phi 62$ ( $\phi 63.8$ )	58	$\phi 16$	$\phi 52$	24	35	39.57	29.9	15	50°04'	$\phi 31.57$	556.1

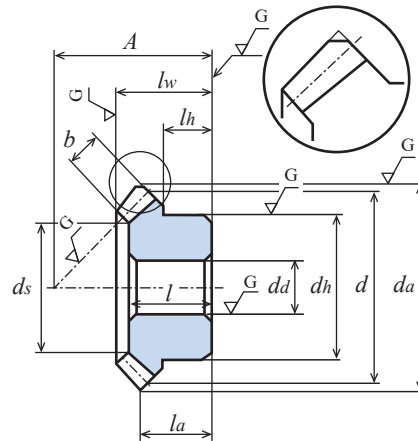

Allowable transfer capability for different revolutions per minute Bending strength (Unit: kW)									Allowable transfer capability for different revolutions per minute Surface durability (Unit: kW)								Backlash (Unit: mm)	Catalogue number	
250 rpm	500 rpm	800 rpm	1,000 rpm	1,500 rpm	2,000 rpm	2,500 rpm	3,000 rpm	4,000 rpm	250 rpm	500 rpm	800 rpm	1,000 rpm	1,500 rpm	2,000 rpm	2,500 rpm	3,000 rpm			4,000 rpm
0.15	0.31	0.48	0.59	0.86	1.11	1.36	1.61	2.09	0.08	0.17	0.27	0.33	0.49	0.64	0.79	0.94	1.24	0.03 to 0.06	<b>MG1.5S 20R – 3008H</b> <b>MG1.5S 20L – 3008H</b>
0.23	0.47	0.72	0.89	1.27	1.66	2.03	2.40	3.11	0.15	0.32	0.50	0.62	0.91	1.20	1.48	1.76	2.32	0.03 to 0.06	<b>MG1.5S 25R – 3410H</b> <b>MG1.5S 25L – 3410H</b>
0.33	0.65	1.01	1.23	1.77	2.30	2.83	3.33	4.26	0.26	0.53	0.84	1.04	1.52	2.00	2.48	2.95	3.82	0.03 to 0.06	<b>MG1.5S 30R – 4310H</b> <b>MG1.5S 30L – 4310H</b>
0.35	0.69	1.07	1.31	1.88	2.45	3.00	3.55	4.58	0.19	0.39	0.61	0.76	1.11	1.46	1.80	2.15	2.81	0.04 to 0.08	<b>MG2S 20R – 3712H</b> <b>MG2S 20L – 3712H</b>
0.55	1.08	1.66	2.03	2.93	3.80	4.66	5.49	6.95	0.37	0.76	1.19	1.47	2.16	2.84	3.51	4.17	5.35	0.04 to 0.08	<b>MG2S 25R – 4012H</b> <b>MG2S 25L – 4012H</b>
0.72	1.41	2.16	2.63	3.80	4.95	6.05	7.04	8.79	0.59	1.19	1.86	2.29	3.37	4.44	5.49	6.43	8.13	0.04 to 0.08	<b>MG2S 30R – 5012H</b> <b>MG2S 30L – 5012H</b>
0.66	1.29	1.99	2.43	3.50	4.55	5.58	6.57	8.32	0.37	0.74	1.17	1.44	2.12	2.78	3.44	4.09	5.24	0.05 to 0.1	<b>MG2.5S 20R – 4814H</b> <b>MG2.5S 20L – 4814H</b>
1.07	2.07	3.16	3.86	5.58	7.26	8.86	10.28	-	0.74	1.49	2.32	2.86	4.21	5.55	6.83	7.99	-	0.05 to 0.1	<b>MG2.5S 25R – 5016H</b> <b>MG2.5S 25L – 5016H</b>
1.41	2.69	4.09	5.02	7.27	9.43	11.33	13.08	-	1.18	2.33	3.61	4.48	6.59	8.66	10.51	12.23	-	0.05 to 0.1	<b>MG2.5S 30R – 6216H</b> <b>MG2.5S 30L – 6216H</b>
1.16	2.25	3.44	4.19	6.07	7.90	9.66	11.23	14.03	0.66	1.32	2.06	2.53	3.74	4.92	6.08	7.13	9.01	0.06 to 0.12	<b>MG3S 20R – 5816H</b> <b>MG3S 20L – 5816H</b>



This product has the same shape as the former MF Series and its tooth surfaces have been finished by grinding.

Unit: mm

Accuracy Class	Material	Pressure angle	Helix angle	Heat treatment	Tooth surface hardness	Backlash ①
[JIS B 1704] 2	SCM435/440	20°	35°	Induction hardening of teeth	HRC49 to 55	See the table below.

★ No surface treatment is applied.

★ The allowable transfer capability table was prepared based on the assumption that a left-hand gear is used on the input side.

★ This allowable transfer capability table was prepared by using the formulas presented by the JGMA (Japan Gear Manufacturers Association). For the unit conversion method, refer to P. 20 in "References."

★ The values in parentheses below "Tip diameter  $d_a$ " are theoretical values. The actual maximum diameter is the value obtained after the teeth are chamfered parallel to the shaft center.

★ Gears with a [#] are provided with key grooves, keys, two screw holes, and two set screws.

① This is a theoretical value obtained when a pair of gears of the same type and material are meshed with each other.

Catalogue number	Gear ratio	Number of teeth	Reference diameter	Tip diameter	As-sembly distance	Hole diameter	Hub diameter	Hub length	Hole length	Over-all length	Dis-tance from end face to tip	Face width	Key groove	Screw		Tip angle	Counterbore diameter (Reference value)	Weight	
														$M$	$l_s$				
	$u$	$z$	$d$	$d_a$	$A$	$d_d(H7)$	$d_h$	$l_h$	$l$	$l_w$	$l_a$	$b$	$b_2 \times t_2$			$\delta_a$	$d_s$	$W(g)$	
MGE1.5S 19R – 2810H	1 : 1	19	$\phi 28.5$	$\phi 28.5$ <sup>(<math>\phi 30.34</math>)</sup>	28	$\phi 10$	$\phi 25$	12	16	18.19	14.67	5.5	-	-	-	50°23'	$\phi 17.4$	54.7	
MGE1.5S 19L – 2810H		19	$\phi 28.5$	$\phi 28.5$ <sup>(<math>\phi 30.34</math>)</sup>	28	$\phi 10$	$\phi 25$	12	16	18.19	14.67	5.5	-	-	-	50°23'	$\phi 17.4$	54.7	
MGE2S 19R – 3512H		19	$\phi 38$	$\phi 38.0$	$\phi 38.0$ <sup>(<math>\phi 40.43</math>)</sup>	35	$\phi 12$	$\phi 32$	13	19	22.09	17.21	7.5	-	-	-	49°39'	$\phi 22.8$	113.4
MGE2S 19L – 3512H		19	$\phi 38$	$\phi 38.0$	$\phi 38.0$ <sup>(<math>\phi 40.43</math>)</sup>	35	$\phi 12$	$\phi 32$	13	19	22.09	17.21	7.5	-	-	-	49°39'	$\phi 22.8$	113.4
MGE2S 23R – 4015H		23	$\phi 46$	$\phi 46.0$	$\phi 46.0$ <sup>(<math>\phi 48.52</math>)</sup>	40	$\phi 15$	$\phi 40$	14	21	24.43	18.26	9.5	-	-	-	49°39'	$\phi 27.1$	191.9
MGE2S 23L – 4015H		23	$\phi 46$	$\phi 46.0$	$\phi 46.0$ <sup>(<math>\phi 48.52</math>)</sup>	40	$\phi 15$	$\phi 40$	14	21	24.43	18.26	9.5	-	-	-	49°39'	$\phi 27.1$	191.9
MGE2S 23R # 4020H		23	$\phi 46$	$\phi 46.0$	$\phi 46.0$ <sup>(<math>\phi 48.52</math>)</sup>	40	$\phi 20$	$\phi 40$	14	21	24.43	18.26	9.5	6 × 2.8	2-M5	9	49°39'	$\phi 27.1$	166.5
MGE2S 23L # 4020H		23	$\phi 46$	$\phi 46.0$	$\phi 46.0$ <sup>(<math>\phi 48.52</math>)</sup>	40	$\phi 20$	$\phi 40$	14	21	24.43	18.26	9.5	6 × 2.8	2-M5	9	49°39'	$\phi 27.1$	166.5
MGE2.5S 19R – 4215H		19	$\phi 47.5$	$\phi 47.5$	$\phi 47.5$ <sup>(<math>\phi 50.55</math>)</sup>	42	$\phi 15$	$\phi 40$	14.5	23	25.93	19.78	9.5	-	-	-	49°48'	$\phi 30.1$	210.8
MGE2.5S 19L – 4215H		19	$\phi 47.5$	$\phi 47.5$	$\phi 47.5$ <sup>(<math>\phi 50.55</math>)</sup>	42	$\phi 15$	$\phi 40$	14.5	23	25.93	19.78	9.5	-	-	-	49°48'	$\phi 30.1$	210.8
MGE2.5S 23R – 4815H		23	$\phi 57.5$	$\phi 57.5$	$\phi 57.5$ <sup>(<math>\phi 60.63</math>)</sup>	48	$\phi 15$	$\phi 50$	15.5	24	28.30	20.81	11.5	-	-	-	49°30'	$\phi 34.5$	363.9
MGE2.5S 23L – 4815H		23	$\phi 57.5$	$\phi 57.5$	$\phi 57.5$ <sup>(<math>\phi 60.63</math>)</sup>	48	$\phi 15$	$\phi 50$	15.5	24	28.30	20.81	11.5	-	-	-	49°30'	$\phi 34.5$	363.9
MGE3S 19R – 5020H		19	$\phi 57$	$\phi 57.0$	$\phi 57.0$ <sup>(<math>\phi 60.68</math>)</sup>	50	$\phi 20$	$\phi 48$	17	27	31.09	23.34	12.0	-	-	-	49°56'	$\phi 34.1$	347.8
MGE3S 19L – 5020H		19	$\phi 57$	$\phi 57.0$	$\phi 57.0$ <sup>(<math>\phi 60.68</math>)</sup>	50	$\phi 20$	$\phi 48$	17	27	31.09	23.34	12.0	-	-	-	49°56'	$\phi 34.1$	347.8
MGE3S 23R – 5520H		23	$\phi 69$	$\phi 68.0$	$\phi 68.0$ <sup>(<math>\phi 72.73</math>)</sup>	55	$\phi 20$	$\phi 60$	16	27	31.51	22.36	14.0	-	-	-	49°22'	$\phi 42.4$	571.3
MGE3S 23L – 5520H		23	$\phi 69$	$\phi 68.0$	$\phi 68.0$ <sup>(<math>\phi 72.73</math>)</sup>	55	$\phi 20$	$\phi 60$	16	27	31.51	22.36	14.0	-	-	-	49°22'	$\phi 42.4$	571.3



2D • 3D CAD

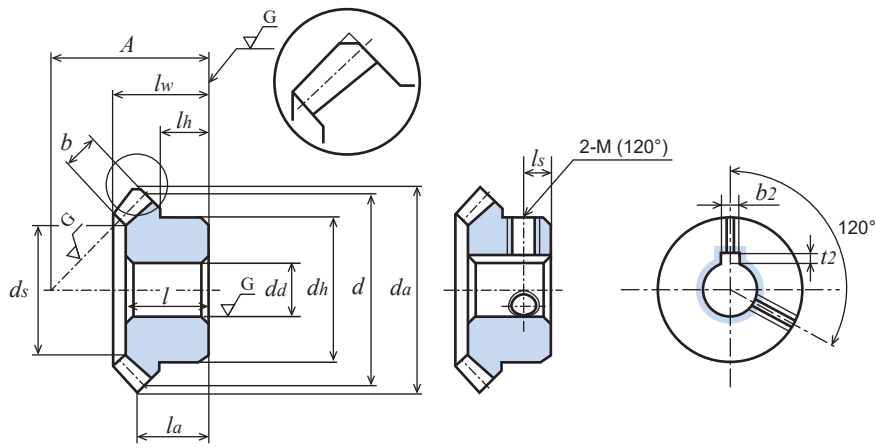

Allowable transfer capability for different revolutions per minute Bending strength (Unit: kW)							Allowable transfer capability for different revolutions per minute Surface durability (Unit: kW)							Backlash (Unit: mm)	Catalogue number
100 rpm	250 rpm	500 rpm	800 rpm	1,000 rpm	1,500 rpm	2,000 rpm	100 rpm	250 rpm	500 rpm	800 rpm	1,000 rpm	1,500 rpm	2,000 rpm		
0.054	0.137	0.274	0.432	0.525	0.736	0.922	0.025	0.067	0.138	0.223	0.273	0.391	0.495	0.05 to 0.12	MGE1.5S 19R – 2810H MGE1.5S 19L – 2810H
0.133	0.334	0.668	1.014	1.223	1.685	2.150	0.064	0.167	0.344	0.533	0.649	0.911	1.178	0.05 to 0.12	MGE2S 19R – 3512H MGE2S 19L – 3512H
0.215	0.539	1.060	1.587	1.901	2.640	3.359	0.123	0.320	0.648	0.991	1.199	1.694	2.183	0.05 to 0.12	MGE2S 23R – 4015H MGE2S 23L – 4015H MGE2S 23R # 4020H MGE2S 23L # 4020H
0.264	0.662	1.298	1.939	2.321	3.228	4.103	0.128	0.335	0.678	1.034	1.250	1.769	2.278	0.06 to 0.15	MGE2.5S 19R – 4215H MGE2.5S 19L – 4215H
0.414	1.036	1.980	2.923	3.474	4.897	6.240	0.240	0.624	1.230	1.853	2.224	3.192	4.119	0.06 to 0.15	MGE2.5S 23R – 4815H MGE2.5S 23L – 4815H
0.472	1.188	2.274	3.360	3.995	5.626	7.166	0.233	0.608	1.201	1.812	2.176	3.119	4.023	0.06 to 0.15	MGE3S 19R – 5020H MGE3S 19L – 5020H
0.726	1.815	3.374	4.916	5.923	8.319	10.061	0.425	1.108	2.123	3.157	3.841	5.493	7.098	0.06 to 0.15	MGE3S 23R – 5520H MGE3S 23L – 5520H





Unit: mm

Accuracy Class	Material	Pressure angle	Helix angle	Heat treatment	Tooth surface hardness	Backlash ①
[JIS B 1704] 3	S45C	20°	35°	—	—	See the table below.

- ★ No surface treatment is applied.
  - ★ The allowable transfer capability table was prepared based on the assumption that a left-hand gear is used on the input side.
  - ★ This allowable transfer capability table was prepared by using the formulas presented by the JGMA (Japan Gear Manufacturers Association). For the unit conversion method, refer to P. 20 in "References."
  - ★ The values in parentheses below "Tip diameter  $d_a$ " are theoretical values. The actual maximum diameter is the value obtained after the teeth are chamfered parallel to the shaft center. (See Fig. 1.)
  - ★ Gears with a [\*] are provided with two screw holes and two set screws.
- ① This is a theoretical value obtained when a pair of gears of the same type and material are meshed with each other.

Catalogue number	Gear ratio	Number of teeth	Reference diameter	Tip diameter	As-sembly distance	Hole diameter	Hub diameter	Hub length	Hole length	Over-all length	Distance from end face to tip	Face width	Screw		Tip angle	Counterbore diameter (Reference value)	Weight
													M	ls			
<b>M80S20R — 1605</b>	1 : 1	20	$\phi 16$	$\phi 17.06$	16	$\phi 5$	$\phi 12$	6	10	10.86	8.53	3.7	-	-	51°15'	$\phi 9.54$	10.5
<b>M80S20L — 1605</b>		20	$\phi 16$	$\phi 17.06$	16	$\phi 5$	$\phi 12$	6	10	10.86	8.53	3.7	-	-	51°15'	$\phi 9.54$	10.5
<b>M80S25R — 1805</b>		25	$\phi 20$	$\phi 21.05$	18	$\phi 5$	$\phi 16$	6	10.5	11.56	8.53	4.7	-	-	49°56'	$\phi 11.71$	18.5
<b>M80S25L — 1805</b>		25	$\phi 20$	$\phi 21.05$	18	$\phi 5$	$\phi 16$	6	10.5	11.56	8.53	4.7	-	-	49°56'	$\phi 11.71$	18.5
<b>M80S30R — 2006</b>		30	$\phi 24$	$\phi 25.06$	20	$\phi 6$	$\phi 18$	6	11	12.2	8.53	5.6	-	-	49°13'	$\phi 14.16$	25.5
<b>M80S30L — 2006</b>		30	$\phi 24$	$\phi 25.06$	20	$\phi 6$	$\phi 18$	6	11	12.2	8.53	5.6	-	-	49°13'	$\phi 14.16$	25.5
<b>M1S 20R — 2106</b>		20	$\phi 20$	$\phi 21.12$	21	$\phi 6$	$\phi 16$	9	13	14.43	11.56	4.5	-	-	50°31'	$\phi 11.3$	19.7
<b>M1S 20L — 2106</b>		20	$\phi 20$	$\phi 21.12$	21	$\phi 6$	$\phi 16$	9	13	14.43	11.56	4.5	-	-	50°31'	$\phi 11.3$	19.7
<b>M1S 20R * 2108</b>		20	$\phi 20$	$\phi 21.12$	21	$\phi 8$	$\phi 16$	9	13	14.43	11.56	4.5	2-M4	4.5	50°31'	$\phi 11.3$	16.9
<b>M1S 20L * 2108</b>		20	$\phi 20$	$\phi 21.12$	21	$\phi 8$	$\phi 16$	9	13	14.43	11.56	4.5	2-M4	4.5	50°31'	$\phi 11.3$	16.9
<b>M1S25R — 2306</b>		25	$\phi 25$	$\phi 26.3$	23	$\phi 6$	$\phi 20$	8	13	14.58	11.15	5.30	-	-	49°47'	$\phi 15.0$	32.9
<b>M1S25L — 2306</b>		25	$\phi 25$	$\phi 26.3$	23	$\phi 6$	$\phi 20$	8	13	14.58	11.15	5.30	-	-	49°47'	$\phi 15.0$	32.9
<b>M1S 30R — 2610</b>		30	$\phi 30$	$\phi 31.09$	26	$\phi 10$	$\phi 22$	9	14.5	15.67	11.54	6.2	-	-	48°21'	$\phi 19.4$	43.0
<b>M1S 30L — 2610</b>		30	$\phi 30$	$\phi 31.09$	26	$\phi 10$	$\phi 22$	9	14.5	15.67	11.54	6.2	-	-	48°21'	$\phi 19.4$	43.0
<b>M1.5S 20R — 2810</b>		20	$\phi 30$	$\phi 31.85$	28	$\phi 10$	$\phi 24$	10	16.5	18.44	13.93	7	-	-	50° 5'	$\phi 17.2$	54.7
<b>M1.5S 20L — 2810</b>		20	$\phi 30$	$\phi 31.85$	28	$\phi 10$	$\phi 24$	10	16.5	18.44	13.93	7	-	-	50° 5'	$\phi 17.2$	54.7
<b>M1.5S25R — 3410</b>		25	$\phi 37.5$	$\phi 39.38$	34	$\phi 10$	$\phi 30$	11.5	19	21.10	16.19	7.5	-	-	49°12'	$\phi 23.79$	105.7
<b>M1.5S25L — 3410</b>		25	$\phi 37.5$	$\phi 39.38$	34	$\phi 10$	$\phi 30$	11.5	19	21.10	16.19	7.5	-	-	49°12'	$\phi 23.79$	105.7
<b>M1.5S 30R — 3812</b>		30	$\phi 45$	$\phi 46.79$	38	$\phi 12$	$\phi 33$	12	21	22.64	16.4	9.3	-	-	47°54'	$\phi 29.7$	152.0
<b>M1.5S 30L — 3812</b>		30	$\phi 45$	$\phi 46.79$	38	$\phi 12$	$\phi 33$	12	21	22.64	16.4	9.3	-	-	47°54'	$\phi 29.7$	152.0
<b>M2S25R — 4012</b>	25	$\phi 50$	$\phi 51.33$ ( $\phi 52.53$ )	40	$\phi 12$	$\phi 42$	11	21	23.13	16.27	10.5	-	-	49°21'	$\phi 32.3$	224.9	
<b>M2S25L — 4012</b>	25	$\phi 50$	$\phi 51.33$ ( $\phi 52.53$ )	40	$\phi 12$	$\phi 42$	11	21	23.13	16.27	10.5	-	-	49°21'	$\phi 32.3$	224.9	
<b>M2S 30R — 5116</b>	30	$\phi 60$	$\phi 60.94$ ( $\phi 62.42$ )	51	$\phi 16$	$\phi 44$	17	28	30.53	22.21	12.4	-	-	47°54'	$\phi 38.9$	358.4	
<b>M2S 30L — 5116</b>	30	$\phi 60$	$\phi 60.94$ ( $\phi 62.42$ )	51	$\phi 16$	$\phi 44$	17	28	30.53	22.21	12.4	-	-	47°54'	$\phi 38.9$	358.4	
<b>M2.5S25R — 5016</b>	25	$\phi 62.5$	$\phi 64.16$ ( $\phi 65.69$ )	50	$\phi 16$	$\phi 52$	13.5	27	29.14	20.35	13.5	-	-	49°30'	$\phi 40.82$	437.6	
<b>M2.5S25L — 5016</b>	25	$\phi 62.5$	$\phi 64.16$ ( $\phi 65.69$ )	50	$\phi 16$	$\phi 52$	13.5	27	29.14	20.35	13.5	-	-	49°30'	$\phi 40.82$	437.6	
<b>M3S25R — 6020</b>	25	$\phi 75$	$\phi 77.0$ ( $\phi 78.66$ )	60	$\phi 20$	$\phi 65$	17.5	32	35.06	24.33	16.2	-	-	48°37'	$\phi 48.18$	777.6	
<b>M3S25L — 6020</b>	25	$\phi 75$	$\phi 77.0$ ( $\phi 78.66$ )	60	$\phi 20$	$\phi 65$	17.5	32	35.06	24.33	16.2	-	-	48°37'	$\phi 48.18$	777.6	



2D • 3D CAD

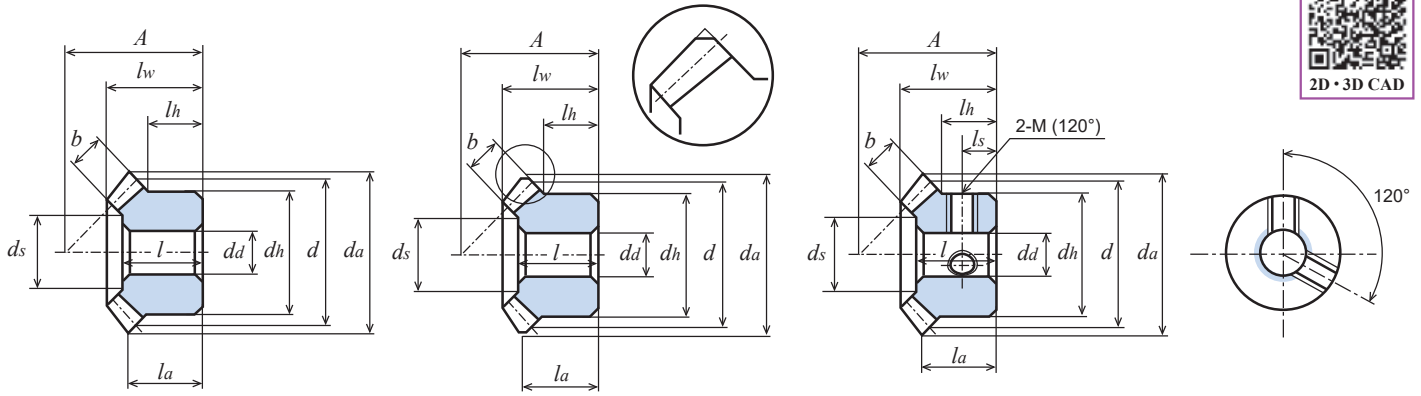

Fig. 1 (Tip chamfering)

Allowable transfer capability for different revolutions per minute Bending strength (Unit: W)							Allowable transfer capability for different revolutions per minute Surface durability (Unit: W)							Backlash (Unit: mm)	Catalogue number
300 rpm	600 rpm	900 rpm	1,200 rpm	1,500 rpm	1,800 rpm	2,000 rpm	300 rpm	600 rpm	900 rpm	1,200 rpm	1,500 rpm	1,800 rpm	2,000 rpm		
17.9	35.8	53.7	71.6	86.2	99.9	108.4	2.3	4.7	7.1	9.5	11.5	13.4	14.7	0.02 to 0.08	<b>M80S20R – 1605</b> <b>M80S20L – 1605</b>
30.6	61.3	92.0	118.1	141.2	162.4	175.6	4.8	9.7	14.7	19.1	23.0	26.6	28.9	0.02 to 0.08	<b>M80S25R – 1805</b> <b>M80S25L – 1805</b>
46.0	92.1	135.6	171.3	203.4	232.5	250.4	8.6	17.4	25.9	33.0	39.5	45.6	49.4	0.02 to 0.08	<b>M80S30R – 2006</b> <b>M80S30L – 2006</b>
34.9	69.9	104.9	134.6	161.0	185.2	200.2	4.6	9.4	14.1	18.2	21.9	25.4	27.6	0.05 to 0.12	<b>M1S 20R – 2106</b> <b>M1S 20L – 2106</b> <b>M1S 20R * 2108</b> <b>M1S 20L * 2108</b>
57.0	113.9	166.4	209.9	248.9	284.0	305.6	9.1	18.3	27.0	34.3	41.0	47.3	51.3	0.05 to 0.12	<b>M1S25R – 2306</b> <b>M1S25L – 2306</b>
84.0	168.0	222.5	279.2	329.7	395.6	428.5	16.1	32.5	49.1	58.7	69.9	80.3	87.7	0.05 to 0.12	<b>M1S 30R – 2610</b> <b>M1S 30L – 2610</b>
123.2	246.4	348.1	435.2	512.0	580.3	628.6	16.7	33.9	48.4	61.1	72.8	83.6	91.3	0.05 to 0.12	<b>M1.5S 20R – 2810</b> <b>M1.5S 20L – 2810</b>
187.5	365.2	504.4	623.1	725.6	847.8	928.3	30.9	61.0	85.4	107.1	126.8	150.5	166.5	0.05 to 0.12	<b>M1.5S25R – 3410</b> <b>M1.5S25L – 3410</b>
286.5	539.5	735.8	899.5	1,079.8	1,262.1	1,378.5	57.1	109.2	151.4	188.7	231.0	274.0	303.9	0.05 to 0.12	<b>M1.5S 30R – 3812</b> <b>M1.5S 30L – 3812</b>
0.462 (kW)	0.851 (kW)	1.152 (kW)	1.414 (kW)	1.716 (kW)	2.001 (kW)	2.188 (kW)	0.078 (kW)	0.147 (kW)	0.203 (kW)	0.254 (kW)	0.315 (kW)	0.375 (kW)	0.416 (kW)	0.05 to 0.12	<b>M2S25R – 4012</b> <b>M2S25L – 4012</b>
0.682 (kW)	1.205 (kW)	1.607 (kW)	2.040 (kW)	2.463 (kW)	2.880 (kW)	3.154 (kW)	0.140 (kW)	0.253 (kW)	0.346 (kW)	0.450 (kW)	0.557 (kW)	0.669 (kW)	0.744 (kW)	0.05 to 0.12	<b>M2S 30R – 5116</b> <b>M2S 30L – 5116</b>
0.923 (kW)	1.612 (kW)	2.143 (kW)	2.742 (kW)	3.306 (kW)	3.873 (kW)	4.238 (kW)	0.160 (kW)	0.286 (kW)	0.391 (kW)	0.513 (kW)	0.635 (kW)	0.764 (kW)	0.849 (kW)	0.06 to 0.15	<b>M2.5S25R – 5016</b> <b>M2.5S25L – 5016</b>
1.557 (kW)	2.657 (kW)	3.615 (kW)	4.615 (kW)	5.591 (kW)	6.530 (kW)	- (kW)	0.276 (kW)	0.485 (kW)	0.681 (kW)	0.896 (kW)	1.122 (kW)	1.346 (kW)	- (kW)	0.06 to 0.15	<b>M3S25R – 6020</b> <b>M3S25L – 6020</b>



Unit: mm

Accuracy Class	Material	Pressure angle	Helix angle	Heat treatment	Tooth surface hardness	Surface treatment	Backlash ①
[JIS B 1704] 4	S45C	20°	35°	Induction hardening of teeth	HRC47 to 53	Black oxide finish	See the table below.

★ The allowable transfer capability table was prepared based on the assumption that a left-hand gear is used on the input side.

★ This allowable transfer capability table was prepared by using the formulas presented by the JGMA (Japan Gear Manufacturers Association). For the unit conversion method, refer to P. 20 in "References."

★ The values in parentheses below "Tip diameter  $d_a$ " are theoretical values. The actual maximum diameter is the value obtained after the teeth are chamfered parallel to the shaft center. (See Fig. 1.)

① This is a theoretical value obtained when a pair of gears of the same type and material are meshed with each other.

Catalogue number	Gear ratio	Number of teeth	Reference diameter	Tip diameter	Assembly distance	Hole diameter	Hub diameter	Hub length	Hole length	Overall length	Distance from end face to tip	Face width	Tip angle	Counterbore diameter (Reference value)	Weight
	$u$	$z$	$d$	$d_a$	$A$	$d_a(H8)$	$d_h$	$l_h$	$l$	$l_w$	$l_a$	$b$	$\delta_a$	$d_s$	$W(g)$
M1S25R – 2306HB	1 : 1	25	$\phi 25$	$\phi 26.3$	23	$\phi 6$	$\phi 20$	8	13	14.58	11.15	5.30	49°47'	$\phi 15.01$	32.9
M1S25L – 2306HB		25	$\phi 25$	$\phi 26.3$	23	$\phi 6$	$\phi 20$	8	13	14.58	11.15	5.30	49°47'	$\phi 15.01$	32.9
M1.5S25R – 3410HB		25	$\phi 37.5$	$\phi 39.38$	34	$\phi 10$	$\phi 30$	11.5	19	21.10	16.19	7.5	49°12'	$\phi 23.79$	105.7
M1.5S25L – 3410HB		25	$\phi 37.5$	$\phi 39.38$	34	$\phi 10$	$\phi 30$	11.5	19	21.10	16.19	7.5	49°12'	$\phi 23.79$	105.7
M2S25R – 4012HB		25	$\phi 50$	$\phi 51.33^{(\phi 52.53)}$	40	$\phi 12$	$\phi 42$	11	21	23.13	16.27	10.5	49°21'	$\phi 32.3$	224.9
M2S25L – 4012HB		25	$\phi 50$	$\phi 51.33^{(\phi 52.53)}$	40	$\phi 12$	$\phi 42$	11	21	23.13	16.27	10.5	49°21'	$\phi 32.3$	224.9
M2.5S25R – 5016HB		25	$\phi 62.5$	$\phi 64.16^{(\phi 65.69)}$	50	$\phi 16$	$\phi 52$	13.5	27	29.14	20.35	13.5	49°30'	$\phi 40.82$	437.6
M2.5S25L – 5016HB		25	$\phi 62.5$	$\phi 64.16^{(\phi 65.69)}$	50	$\phi 16$	$\phi 52$	13.5	27	29.14	20.35	13.5	49°30'	$\phi 40.82$	437.6
M3S25R – 6020HB		25	$\phi 75$	$\phi 77.0^{(\phi 78.66)}$	60	$\phi 20$	$\phi 65$	17.5	32	35.06	24.33	16.2	48°37'	$\phi 48.18$	777.6
M3S25L – 6020HB		25	$\phi 75$	$\phi 77.0^{(\phi 78.66)}$	60	$\phi 20$	$\phi 65$	17.5	32	35.06	24.33	16.2	48°37'	$\phi 48.18$	777.6

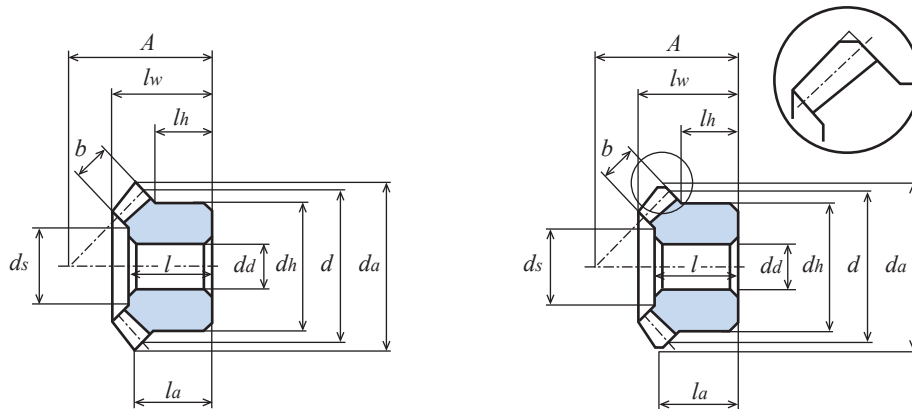

Fig. 1 (Tip chamfering)

Allowable transfer capability for different revolutions per minute Bending strength (Unit: W)							Allowable transfer capability for different revolutions per minute Surface durability (Unit: W)							Backlash (Unit: mm)	Catalogue number
300 rpm	600 rpm	900 rpm	1,200 rpm	1,500 rpm	1,800 rpm	2,000 rpm	300 rpm	600 rpm	900 rpm	1,200 rpm	1,500 rpm	1,800 rpm	2,000 rpm		
49.7	99.4	145.6	184.4	219.6	251.7	271.4	24.9	51.3	76.5	98.1	118.0	136.3	147.7	0.05 to 0.12	<b>M1S 25R – 2306HB</b> <b>M1S 25L – 2306HB</b>
163.6	319.4	444.2	552.1	646.4	756.7	829.3	83.8	168.7	238.9	300.7	355.5	419.4	461.9	0.05 to 0.12	<b>M1.5S 25R – 3410HB</b> <b>M1.5S 25L – 3410HB</b>
0.403 (kW)	0.748 (kW)	1.021 (kW)	1.261 (kW)	1.533 (kW)	1.791 (kW)	-	0.210 (kW)	0.403 (kW)	0.559 (kW)	0.699 (kW)	0.859 (kW)	1.011 (kW)	-	0.05 to 0.12	<b>M2S 25R – 4012HB</b> <b>M2S 25L – 4012HB</b>
0.805 (kW)	1.423 (kW)	1.909 (kW)	2.449 (kW)	2.961 (kW)	-	-	0.427 (kW)	0.778 (kW)	1.062 (kW)	1.380 (kW)	1.685 (kW)	-	-	0.06 to 0.15	<b>M2.5S 25R – 5016HB</b> <b>M2.5S 25L – 5016HB</b>
1.362 (kW)	2.354 (kW)	3.226 (kW)	4.131 (kW)	-	-	-	0.732 (kW)	1.305 (kW)	1.820 (kW)	2.360 (kW)	-	-	-	0.06 to 0.15	<b>M3S 25R – 6020HB</b> <b>M3S 25L – 6020HB</b>



Unit: mm

Accuracy Class	Material	Pressure angle	Helix angle	Heat treatment	Tooth surface hardness	Backlash ①
[JIS B 1704] 4	S45C	20°	35°	Induction hardening of teeth	HRC47 to 53	See the table below.

- ★ No surface treatment is applied.
  - ★ The allowable transfer capability table was prepared based on the assumption that a left-hand gear is used on the input side.
  - ★ This allowable transfer capability table was prepared by using the formulas presented by the JGMA (Japan Gear Manufacturers Association). For the unit conversion method, refer to P. 20 in "References."
  - ★ Gears with a [\*] are provided with two screw holes and two set screws. Gears with a [#] are provided with key grooves, keys, screw holes, and set screws.
  - ★ The values in parentheses below "Tip diameter  $d_a$ " are theoretical values. The actual maximum diameter is the value obtained after the teeth are chamfered parallel to the shaft center. (See Fig. 1.)
- ① This is a theoretical value obtained when a pair of gears of the same type and material are meshed with each other.

Catalogue number	Gear ratio	Number of teeth	Reference diameter	Tip diameter	Assembly distance	Hole diameter	Hub diameter	Hub length	Hole length	Overall length	Distance from end face to tip	Face width	Key groove	Screw		Tip angle	Counter-bore diameter (Reference value)	Weight	
														M	ls				
	$u$	$z$	$d$	$d_a$	$A$	$d_a(H8)$	$d_h$	$l_h$	$l$	$l_w$	$l_a$	$b$	$b_2 \times t_2$	$\delta_a$	$d_s$	$W(g)$			
M1S25R – 2306H	1 : 1	25	$\phi 25$	$\phi 26.3$	23	$\phi 6$	$\phi 20$	8	13	14.58	11.15	5.30	-	-	-	49°47'	$\phi 15.01$	32.9	
M1S25L – 2306H		25	$\phi 25$	$\phi 26.3$	23	$\phi 6$	$\phi 20$	8	13	14.58	11.15	5.30	-	-	-	49°47'	$\phi 15.01$	32.9	
M1S 30R * 2610H		30	$\phi 30$	$\phi 31.09$	26	$\phi 10$	$\phi 22$	9	14.5	15.67	11.54	6.2	-	2-M5	4.5	48°21'	$\phi 19.4$	41.5	
M1S 30L * 2610H		30	$\phi 30$	$\phi 31.09$	26	$\phi 10$	$\phi 22$	9	14.5	15.67	11.54	6.2	-	2-M5	4.5	48°21'	$\phi 19.4$	41.5	
M1.5S 20R – 2810H		20	$\phi 30$	$\phi 31.85$	28	$\phi 10$	$\phi 24$	10	16.5	18.44	13.93	7	-	-	-	50° 5'	$\phi 17.2$	54.7	
M1.5S 20L – 2810H		20	$\phi 30$	$\phi 31.85$	28	$\phi 10$	$\phi 24$	10	16.5	18.44	13.93	7	-	-	-	50° 5'	$\phi 17.2$	54.7	
M1.5S 20R # 2812H		20	$\phi 30$	$\phi 31.85$	28	$\phi 12$	$\phi 24$	10	16.5	18.44	13.93	7	4 × 1.8	2-M4	5	50° 5'	$\phi 17.2$	49.1	
M1.5S 20L # 2812H		20	$\phi 30$	$\phi 31.85$	28	$\phi 12$	$\phi 24$	10	16.5	18.44	13.93	7	4 × 1.8	2-M4	5	50° 5'	$\phi 17.2$	49.1	
M1.5S25R – 3410H		25	$\phi 37.5$	$\phi 39.38$	34	$\phi 10$	$\phi 30$	11.5	19	21.10	16.19	7.5	-	-	-	49°12'	$\phi 23.79$	105.7	
M1.5S25L – 3410H		25	$\phi 37.5$	$\phi 39.38$	34	$\phi 10$	$\phi 30$	11.5	19	21.10	16.19	7.5	-	-	-	49°12'	$\phi 23.79$	105.7	
M1.5S 30R – 3812H		30	$\phi 45$	$\phi 46.79$	38	$\phi 12$	$\phi 33$	12	21	22.64	16.4	9.3	-	-	-	47°54'	$\phi 29.7$	152.0	
M1.5S 30L – 3812H		30	$\phi 45$	$\phi 46.79$	38	$\phi 12$	$\phi 33$	12	21	22.64	16.4	9.3	-	-	-	47°54'	$\phi 29.7$	152.0	
For all the weight values below, the unit is kg.																			
M2S 20R – 3712H		1 : 1	20	$\phi 40$	$\phi 40.8$ ( $\phi 42.28$ )	37	$\phi 12$	$\phi 34$	14	21	24.16	18.14	9	-	-	-	48° 3'	$\phi 22.5$	0.14
M2S 20L – 3712H			20	$\phi 40$	$\phi 40.8$ ( $\phi 42.28$ )	37	$\phi 12$	$\phi 34$	14	21	24.16	18.14	9	-	-	-	48° 3'	$\phi 22.5$	0.14
M2S 20R # 3715H			20	$\phi 40$	$\phi 40.8$ ( $\phi 42.28$ )	37	$\phi 15$	$\phi 34$	14	21	24.16	18.14	9	5 × 2.3	2-M5	7	48° 3'	$\phi 22.5$	0.13
M2S 20L # 3715H	20		$\phi 40$	$\phi 40.8$ ( $\phi 42.28$ )	37	$\phi 15$	$\phi 34$	14	21	24.16	18.14	9	5 × 2.3	2-M5	7	48° 3'	$\phi 22.5$	0.13	
M2S 20R – 2812H	20		$\phi 40$	$\phi 40.8$ ( $\phi 42.28$ )	28	$\phi 12$	$\phi 34$	5	12	15.16	9.14	9	-	-	-	48° 3'	$\phi 22.5$	0.09	
M2S 20L – 2812H	20		$\phi 40$	$\phi 40.8$ ( $\phi 42.28$ )	28	$\phi 12$	$\phi 34$	5	12	15.16	9.14	9	-	-	-	48° 3'	$\phi 22.5$	0.09	
M2S25R – 4012H	25		$\phi 50$	$\phi 51.33$ ( $\phi 52.53$ )	40	$\phi 12$	$\phi 42$	11	21	23.13	16.27	10.5	-	-	-	49°21'	$\phi 32.3$	0.23	
M2S25L – 4012H	25		$\phi 50$	$\phi 51.33$ ( $\phi 52.53$ )	40	$\phi 12$	$\phi 42$	11	21	23.13	16.27	10.5	-	-	-	49°21'	$\phi 32.3$	0.23	
M2S 30R – 5116H	30		$\phi 60$	$\phi 60.94$ ( $\phi 62.42$ )	51	$\phi 16$	$\phi 44$	17	28	30.53	22.21	12.4	-	-	-	47°54'	$\phi 38.9$	0.36	
M2S 30L – 5116H	30		$\phi 60$	$\phi 60.94$ ( $\phi 62.42$ )	51	$\phi 16$	$\phi 44$	17	28	30.53	22.21	12.4	-	-	-	47°54'	$\phi 38.9$	0.36	
M2.5S 20R – 4814H	20		$\phi 50$	$\phi 51.14$ ( $\phi 53.02$ )	48	$\phi 14$	$\phi 42$	19	28	31.77	24.51	11.1	-	-	-	49°20'	$\phi 28.6$	0.30	
M2.5S 20L – 4814H	20		$\phi 50$	$\phi 51.14$ ( $\phi 53.02$ )	48	$\phi 14$	$\phi 42$	19	28	31.77	24.51	11.1	-	-	-	49°20'	$\phi 28.6$	0.30	
M2.5S 20R # 4820H	20		$\phi 50$	$\phi 51.14$ ( $\phi 53.02$ )	48	$\phi 20$	$\phi 42$	19	28	31.77	24.51	11.1	6 × 2.8	2-M5	9.5	49°20'	$\phi 28.6$	0.26	
M2.5S 20L # 4820H	20		$\phi 50$	$\phi 51.14$ ( $\phi 53.02$ )	48	$\phi 20$	$\phi 42$	19	28	31.77	24.51	11.1	6 × 2.8	2-M5	9.5	49°20'	$\phi 28.6$	0.26	
M2.5S25R – 5016H	25		$\phi 62.5$	$\phi 64.16$ ( $\phi 65.69$ )	50	$\phi 16$	$\phi 52$	13.5	27	29.14	20.35	13.5	-	-	-	49°30'	$\phi 40.82$	0.44	
M2.5S25L – 5016H	25		$\phi 62.5$	$\phi 64.16$ ( $\phi 65.69$ )	50	$\phi 16$	$\phi 52$	13.5	27	29.14	20.35	13.5	-	-	-	49°30'	$\phi 40.82$	0.44	
M2.5S 30R – 6318H	30	$\phi 75$	$\phi 76.2$ ( $\phi 78.05$ )	63	$\phi 18$	$\phi 55$	20	34.5	37.07	27.03	15	-	-	-	48° 3'	$\phi 50.6$	0.71		
M2.5S 30L – 6318H	30	$\phi 75$	$\phi 76.2$ ( $\phi 78.05$ )	63	$\phi 18$	$\phi 55$	20	34.5	37.07	27.03	15	-	-	-	48° 3'	$\phi 50.6$	0.71		
M3S 20R – 5816H	20	$\phi 60$	$\phi 61.39$ ( $\phi 63.66$ )	58	$\phi 16$	$\phi 50$	23	35	38.95	29.83	14	-	-	-	49°30'	$\phi 34.4$	0.52		
M3S 20L – 5816H	20	$\phi 60$	$\phi 61.39$ ( $\phi 63.66$ )	58	$\phi 16$	$\phi 50$	23	35	38.95	29.83	14	-	-	-	49°30'	$\phi 34.4$	0.52		
M3S25R – 6020H	25	$\phi 75$	$\phi 77.0$ ( $\phi 78.66$ )	60	$\phi 20$	$\phi 65$	17.5	32	35.06	24.33	16.2	-	-	-	48°37'	$\phi 48.18$	0.78		
M3S25L – 6020H	25	$\phi 75$	$\phi 77.0$ ( $\phi 78.66$ )	60	$\phi 20$	$\phi 65$	17.5	32	35.06	24.33	16.2	-	-	-	48°37'	$\phi 48.18$	0.78		
M3S 30R – 7522H	30	$\phi 90$	$\phi 91.28$ ( $\phi 93.46$ )	75	$\phi 22$	$\phi 66$	24	40	44.38	31.73	18.6	-	-	-	47°11'	$\phi 57.4$	1.19		
M3S 30L – 7522H	30	$\phi 90$	$\phi 91.28$ ( $\phi 93.46$ )	75	$\phi 22$	$\phi 66$	24	40	44.38	31.73	18.6	-	-	-	47°11'	$\phi 57.4$	1.19		

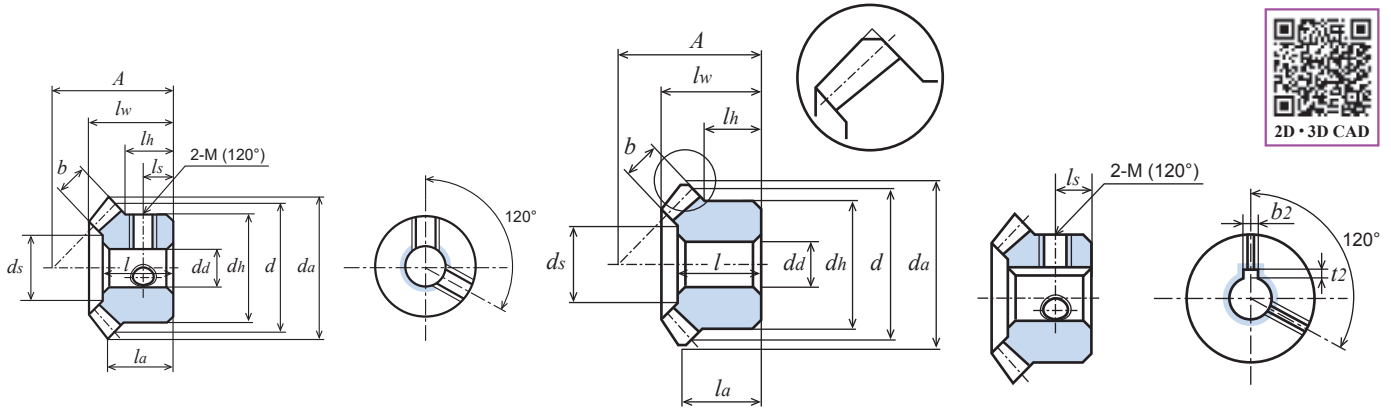

Fig. 1 (Tip chamfering)

Allowable transfer capability for different revolutions per minute Bending strength (Unit: W)							Allowable transfer capability for different revolutions per minute Surface durability (Unit: W)							Backlash (Unit: mm)	Catalogue number
300 rpm	600 rpm	900 rpm	1,200 rpm	1,500 rpm	1,800 rpm	2,000 rpm	300 rpm	600 rpm	900 rpm	1,200 rpm	1,500 rpm	1,800 rpm	2,000 rpm		
49.7	99.4	145.6	184.4	219.6	251.7	271.4	24.9	51.3	76.5	98.1	118.0	136.3	147.7	0.05 to 0.12	M1S25R – 2306H M1S25L – 2306H
73.3	146.6	198.1	254.5	298.5	348.7	387.5	43.6	90.0	130.7	167.2	200.4	230.8	250.8	0.05 to 0.12	M1S 30R * 2610H M1S 30L * 2610H
107.5	215.1	306.9	387.5	460.0	525.5	568.4	45.5	93.8	136.2	174.2	208.8	240.5	261.4	0.05 to 0.12	M1.5S 20R – 2810H M1.5S 20L – 2810H M1.5S 20R # 2812H M1.5S 20L # 2812H
163.6	319.4	444.2	552.1	646.4	756.7	829.3	83.8	168.7	238.9	300.7	355.5	419.4	461.9	0.05 to 0.12	M1.5S25R – 3410H M1.5S25L – 3410H
250.1	475.6	658.2	814.5	966.1	1,108.9	1,197.3	152.8	299.7	422.1	529.0	633.7	733.1	795.3	0.05 to 0.12	M1.5S 30R – 3812H M1.5S 30L – 3812H
For all the values below, the unit is kW.															
0.251	0.488	0.680	0.847	0.998	1.150	1.245	0.108	0.216	0.307	0.387	0.460	0.535	0.581	0.05 to 0.12	M2S 20R – 3712H M2S 20L – 3712H M2S 20R # 3715H M2S 20L # 3715H
0.251	0.488	0.680	0.847	0.998	1.150	1.245	0.108	0.216	0.307	0.387	0.460	0.535	0.581	0.05 to 0.12	M2S 20R – 2812H M2S 20L – 2812H
0.403	0.748	1.021	1.261	1.533	1.791	-	0.210	0.403	0.559	0.699	0.859	1.011	-	0.05 to 0.12	M2S25R – 4012H M2S25L – 4012H
0.596	1.073	1.455	1.814	2.139	-	-	0.371	0.690	0.952	1.202	1.432	-	-	0.05 to 0.12	M2S 30R – 5116H M2S 30L – 5116H
0.491	0.916	1.259	1.556	1.850	2.115	-	0.214	0.411	0.576	0.721	0.865	0.997	-	0.06 to 0.15	M2.5S 20R – 4814H M2.5S 20L – 4814H M2.5S 20R # 4820H M2.5S 20L # 4820H
0.805	1.423	1.909	2.449	2.961	-	-	0.427	0.778	1.062	1.380	1.685	-	-	0.06 to 0.15	M2.5S25R – 5016H M2.5S25L – 5016H
1.117	1.953	2.647	3.281	-	-	-	0.709	1.278	1.763	2.213	-	-	-	0.06 to 0.15	M2.5S 30R – 6318H M2.5S 30L – 6318H
0.878	1.582	2.146	2.674	3.155	-	-	0.387	0.719	0.993	1.253	1.493	-	-	0.06 to 0.15	M3S 20R – 5816H M3S 20L – 5816H
1.362	2.354	3.226	4.131	-	-	-	0.732	1.305	1.820	2.360	-	-	-	0.06 to 0.15	M3S25R – 6020H M3S25L – 6020H
1.922	3.291	4.481	-	-	-	-	1.237	2.184	3.026	-	-	-	-	0.06 to 0.15	M3S 30R – 7522H M3S 30L – 7522H



Unit: mm

Accuracy Class	Material	Pressure angle	Helix angle	Heat treatment	Tooth surface hardness	Backlash ①	Number of teeth of all gears
[JIS B 1704] 4	S45C	20°	35°	Induction hardening of teeth	HRC47 to 53	See the table below.	20

★ No surface treatment is applied.

★ The allowable transfer capability table was prepared based on the assumption that a left-hand gear is used on the input side.

★ This allowable transfer capability table was prepared by using the formulas presented by the JGMA (Japan Gear Manufacturers Association). For the unit conversion method, refer to P. 20 in "References."

★ The values in parentheses below "Tip diameter  $d_a$ " are theoretical values. The actual maximum diameter is the value obtained after the teeth are chamfered parallel to the shaft center.

★ For the MGH Series, the teeth have been finished by induction hardening and the holes have been finished by grinding. Also, keys and set screws are provided. This product can be used without additional machining.

★ Gears with a [+] are provided with screw holes and set screws, and gears with a [=] are provided with keys and key grooves.

① This is a theoretical value obtained when a pair of gears of the same type and material are meshed with each other.

Catalogue number	Gear ratio	Module	Reference diameter	Tip diameter	As-assembly distance	Hole diameter	Hub diameter	Hub length	Hole length	Over-all length	Distance from end face to tip	Face width	Key groove	Screw		Tip angle	Weight
														$M$	$l_s$		
<b>MGH R+ 8</b>	1 : 1	1	$\phi 20$	$\phi 21.12$	20	$\phi 8$	$\phi 16$	8	12	13.43	10.56	4.5	-	M4	4	50°31'	16.0
<b>MGH L+ 8</b>		1	$\phi 20$	$\phi 21.12$	20	$\phi 8$	$\phi 16$	8	12	13.43	10.56	4.5	-	M4	4	50°31'	16.0
<b>MGH R+ 10</b>		1.25	$\phi 25$	$\phi 26.42$	25	$\phi 10$	$\phi 20$	10	15.5	17.13	13.21	6	-	M4	5	49°22'	32.0
<b>MGH L+ 10</b>		1.25	$\phi 25$	$\phi 26.42$	25	$\phi 10$	$\phi 20$	10	15.5	17.13	13.21	6	-	M4	5	49°22'	32.0
<b>MGH R= 12</b>		1.5	$\phi 30$	$\phi 31.85$	30	$\phi 12$	$\phi 24$	12	18.5	20.44	15.93	7	4 × 1.8	M5	6	50° 5'	54.9
<b>MGH L= 12</b>		1.5	$\phi 30$	$\phi 31.85$	30	$\phi 12$	$\phi 24$	12	18.5	20.44	15.93	7	4 × 1.8	M5	6	50° 5'	54.9
<b>MGH R= 14</b>		2	$\phi 40$	$\phi 40.88$ ( $\phi 42.28$ )	40	$\phi 14$	$\phi 32$	16	24	27.16	21.14	9	5 × 2.3	M5	8	48° 3'	137.6
<b>MGH L= 14</b>		2	$\phi 40$	$\phi 40.88$ ( $\phi 42.28$ )	40	$\phi 14$	$\phi 32$	16	24	27.16	21.14	9	5 × 2.3	M5	8	48° 3'	137.6

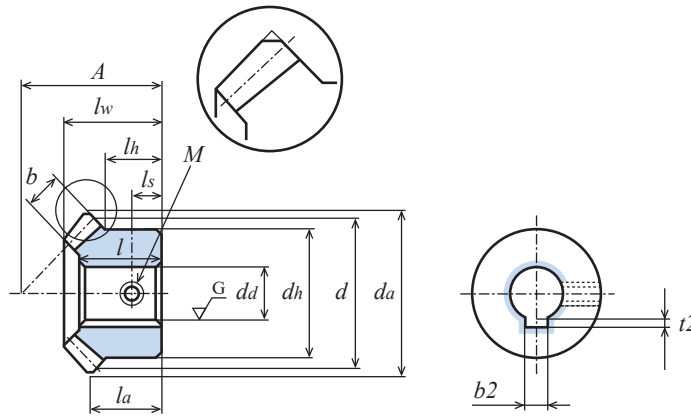

Allowable transfer capability for different revolutions per minute Bending strength (Unit: kW)							Allowable transfer capability for different revolutions per minute Surface durability (Unit: kW)							Backlash (Unit: mm)	Catalogue number
300 rpm	600 rpm	900 rpm	1,200 rpm	1,500 rpm	1,800 rpm	2,000 rpm	300 rpm	600 rpm	900 rpm	1,200 rpm	1,500 rpm	1,800 rpm	2,000 rpm		
0.030	0.061	0.091	0.118	0.142	0.164	0.179	0.012	0.026	0.040	0.052	0.063	0.074	0.081	0.05 to 0.12	<b>MGH R + 8</b> <b>MGH L + 8</b>
0.062	0.125	0.184	0.234	0.280	0.322	0.348	0.026	0.054	0.081	0.104	0.126	0.146	0.158	0.05 to 0.12	<b>MGH R + 10</b> <b>MGH L + 10</b>
0.107	0.215	0.297	0.387	0.460	0.525	0.568	0.045	0.093	0.136	0.174	0.208	0.240	0.261	0.05 to 0.12	<b>MGH R = 12</b> <b>MGH L = 12</b>
0.251	0.488	0.680	0.847	0.998	1.150	1.245	0.108	0.216	0.307	0.387	0.460	0.535	0.581	0.05 to 0.12	<b>MGH R = 14</b> <b>MGH L = 14</b>



# ML-N: B-LOCK Simplified Lock

## Straight Miter (S45C)

Module 1/1.5/2/2.5

Gear Ratio 1 : 1



New product

The ML-N Series is the successor of the former ML Series (S45C).

Unit: mm

Accuracy Class	Material	Pressure angle	Heat treatment	Tooth surface hardness	Backlash ①
[JIS B 1704] 3	S45C	20°	—	—	See the table below.

★ No surface treatment is applied. Set screws are attached to the main body.

★ This allowable transfer capability table was prepared by using the formulas presented by the JGMA (Japan Gear Manufacturers Association). For the unit conversion method, refer to P. 20 in "References."

★ This product is fastened to the shaft by tightening set screws to generate a frictional force, thereby preventing damage to the shaft.

① This is a theoretical value obtained when a pair of gears of the same type and material are meshed with each other.

Catalogue number	Gear ratio	Number of teeth	Reference diameter	Tip diameter	Assembly distance	Hole diameter	Hub diameter	Hub length	Hole length	Overall length	Distance from end face to tip	Face width	Screw		Tip angle	Counterbore diameter (Reference value)	Weight
													M	ls			
ML1S 20 – 2108N	1 : 1	20	φ20	φ21.41	21	φ 8	φ18	10	13	14.48	11.71	4.3	M3	4	49° 3'	φ11.8	19.5
ML1.5S 20 – 3010N		20	φ30	φ32.12	30	φ10	φ24	12	18.5	20.38	16.06	6.8	M4	5	49° 3'	φ17.7	54.6
ML1.5S 25 – 3412N		25	φ37.5	φ39.62	34	φ12	φ30	12.5	19	21.11	16.31	7.5	M5	5.5	48°51'	φ23.8	93.4
ML2S 20 – 3715N		20	φ40	φ41.32	37	φ15	φ34	14	21	23.85	18.41	8.5	M5	6	49° 3'	φ23.9	119.2
ML2.5S 20 – 4820N		20	φ50	φ51.66	48	φ20	φ42	19	28	31.86	24.77	11.1	M6	7.5	49° 3'	φ28.5	236.6

# ML: B-LOCK Simplified Lock

## Straight Miter (sus304)

Module 0.8/1/1.5/2

Gear Ratio 1 : 1



Unit: mm

Accuracy Class	Material	Pressure angle	Heat treatment	Tooth surface hardness	Backlash ①
[JIS B 1704] 4	SUS304	20°	—	—	See the table below.

★ No surface treatment is applied. Set screws are attached to the main body.

★ This allowable transfer capability table was prepared by using the formulas presented by the JGMA (Japan Gear Manufacturers Association). For the unit conversion method, refer to P. 20 in "References."

★ This product is fastened to the shaft by tightening set screws to generate a frictional force, thereby preventing damage to the shaft.

① This is a theoretical value obtained when a pair of gears of the same type and material are meshed with each other.

Catalogue number	Gear ratio	Number of teeth	Reference diameter	Tip diameter	Assembly distance	Hole diameter	Hub diameter	Hub length	Hole length	Overall length	Distance from end face to tip	Face width	Screw		Tip angle	Counterbore diameter (Reference value)	Weight
													M	ls			
ML80SU 20 – 1605	1 : 1	20	φ16	φ17.13	16	φ 5	φ14.5	7.25	10	10.95	8.57	3.7	M2.5	3	49° 3'	φ 9.5	10.2
ML1SU 20 – 2106		20	φ20	φ21.41	21	φ 6	φ16	9	13	14.48	11.71	4.3	M3	4	49° 3'	φ11.8	18.6
ML1SU 30 – 2808		30	φ30	φ31.41	28	φ 8	φ24	11	16.5	17.84	13.71	6.2	M4	5	47°42'	φ19.4	54.3
ML1.5SU 20 – 3010		20	φ30	φ32.12	30	φ10	φ24	12	18.5	20.38	16.06	6.8	M4	5	49° 3'	φ17.7	57.3
ML1.5SU 25 – 3412		25	φ37.5	φ39.62	34	φ12	φ30	12.5	19	21.11	16.31	7.5	M5	5.5	48°51'	φ23.8	94.0
ML2SU 20 – 3715		20	φ40	φ41.32	37	φ15	φ34	14	21	23.85	19.07	8.5	M5	6	49° 3'	φ23.9	121.5

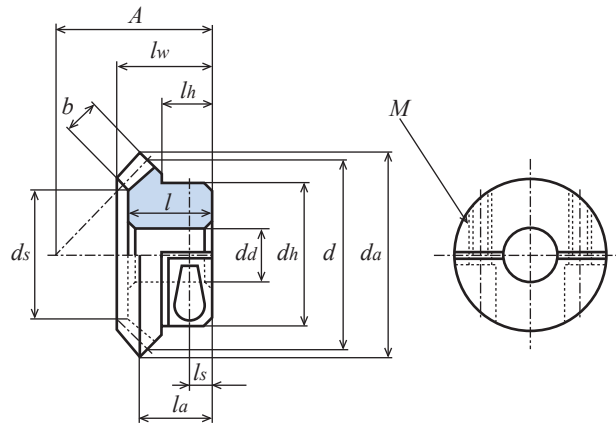

Allowable transfer capability for different revolutions per minute Bending strength (Unit: W)							Recommended tightening torque of screw (Unit: N · m)	Recommended mating gear (KG product)	Backlash (Unit: mm)	Catalogue number
10 rpm	50 rpm	100 rpm	250 rpm	500 rpm	800 rpm	1,000 rpm				
1.0	5.1	10.2	25.6	51.3	82.2	102.0	1.17	<b>M1S 20 – 2106</b>	0.05 to 0.12	<b>ML1S 20 – 2108N</b>
3.5	17.9	35.8	89.7	179.4	277.3	332.8	2.54	<b>M1.5S 20 – 2810</b>	0.05 to 0.12	<b>ML1.5S 20 – 3010N</b>
5.5	27.9	55.8	139.5	279.1	414.4	493.4	5.09	<b>M1.5S 25 – 3410</b>	0.05 to 0.12	<b>ML1.5S 25 – 3412N</b>
8.1	40.8	81.6	204.0	405.4	597.9	710.2	5.09	<b>M2S 20 – 3712</b>	0.05 to 0.12	<b>ML2S 20 – 3715N</b>
16.3	81.9	163.9	409.8	786.6	1141.2	1343.2	7.84	<b>M2.5S 20 – 4814</b>	0.06 to 0.15	<b>ML2.5S 20 – 4820N</b>

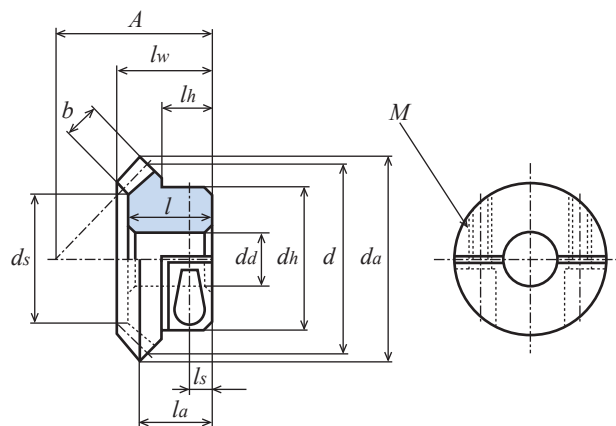

Allowable transfer capability for different revolutions per minute Bending strength (Unit: W)							Recommended tightening torque of screw (Unit: N · m)	Recommended mating gear (KG product)	Backlash (Unit: mm)	Catalogue number
10 rpm	50 rpm	100 rpm	250 rpm	500 rpm	800 rpm	1,000 rpm				
0.2	1.3	2.6	6.5	13.1	20.9	26.2	0.68	<b>M80SU 20 * 1605</b>	0.02 to 0.08	<b>ML80SU 20 – 1605</b>
0.4	2.4	4.8	12.1	24.4	39.1	48.5	0.98	<b>M1SU 20 * 2106</b>	0.05 to 0.12	<b>ML1SU 20 – 2106</b>
1.2	6.1	12.2	30.5	61.1	94.5	113.5	2.45	<b>M1SU 30 * 2608</b>	0.05 to 0.12	<b>ML1SU 30 – 2808</b>
1.6	8.5	17.0	42.7	85.4	132.0	158.4	2.45	<b>M1.5SU 20 – 2810</b>	0.05 to 0.12	<b>ML1.5SU 20 – 3010</b>
2.6	13.2	26.5	66.4	132.9	197.3	234.9	3.92	<b>M1.5SU 25 – 3410</b>	0.05 to 0.12	<b>ML1.5SU 25 – 3412</b>
3.8	19.4	38.8	97.1	193.0	284.7	338.1	3.92	<b>M2SU 20 – 3712</b>	0.05 to 0.12	<b>ML2SU 20 – 3715</b>



Unit: mm

Accuracy Class	Material	Pressure angle	Heat treatment	Tooth surface hardness	Backlash ①
[JIS B 1704] 3	S45C	20°	—	—	See the table below.

★ No surface treatment is applied.

★ This allowable transfer capability table was prepared by using the formulas presented by the JGMA (Japan Gear Manufacturers Association). For the unit conversion method, refer to P. 20 in "References."

★ Gears with a [\*] are provided with two screw holes and set screws, and gears with a [=] are provided with key grooves and keys.

① This is a theoretical value obtained when a pair of gears of the same type and material are meshed with each other.

Catalogue number	Gear ratio	Number of teeth	Reference diameter	Tip diameter	As-sembly distance	Hole diameter	Hub diameter	Hub length	Hole length	Over-all length	Dis-tance from end face to tip	Face width	Key groove	Screw		Tip angle	Counter-bore diameter (Reference value)	Weight
														2-M	ls			
M50S 20 – 1103	1 : 1	20	φ10	φ10.71	11	φ3(H8)	φ 8	5	7	8	6.35	2.5	-	-	-	49° 3'	φ 4.9	2.7
M50S 20 * 1103		20	φ10	φ10.71	11	φ3(H8)	φ 8	5	7	8	6.35	2.5	-	2-M2.5	2.5	49° 3'	φ 4.9	2.5
M50S 25 – 1204		25	φ12.5	φ13.21	12	φ4(H8)	φ11	5	7	8.11	6.10	3.0	-	-	-	48°14'	φ 6.5	5.2
M50S 25 * 1204		25	φ12.5	φ13.21	12	φ4(H8)	φ11	5	7	8.11	6.10	3.0	-	2-M3	3	48°14'	φ 6.5	4.6
M50S 30 – 1404		30	φ15	φ15.71	14	φ4(H8)	φ12	5	8	9.21	6.85	3.5	-	-	-	47°42'	φ 8.1	7.4
M50S 30 * 1404		30	φ15	φ15.71	14	φ4(H8)	φ12	5	8	9.21	6.85	3.5	-	2-M3	3	47°42'	φ 8.1	7.0
M80S 20 – 1605		20	φ16	φ17.13	16	φ 5	φ12	6	10	11	8.57	3.7	-	-	-	49° 3'	φ 9.5	8.7
M80S 20 * 1605		20	φ16	φ17.13	16	φ 5	φ12	6	10	11	8.57	3.7	-	2-M3	3	49° 3'	φ 9.5	8.4
M80S 25 – 1805		25	φ20	φ21.13	18	φ 5	φ16	6	10.5	11.67	8.57	4.7	-	-	-	48°51'	φ11.7	16.8
M1S 20 – 2106		20	φ20	φ21.41	21	φ 6	φ16	9	13	14.53	11.71	4.3	-	-	-	49° 3'	φ11.8	19.7
M1S 20 * 2106		20	φ20	φ21.41	21	φ 6	φ16	9	13	14.53	11.71	4.3	-	2-M4	4.5	49° 3'	φ11.8	18.9
M1S 20 * 2108		20	φ20	φ21.41	21	φ 8	φ16	9	13	14.53	11.71	4.3	-	2-M4	4.5	49° 3'	φ11.8	16.9
M1S 20 – 1406		20	φ20	φ21.41	14	φ 6	φ16	2	6	7.53	4.71	4.3	-	-	-	49° 3'	φ11.8	10.2
M1S 20 = 1408		20	φ20	φ21.41	14	φ 8	φ16	2	6	7.53	4.71	4.3	3 × 1.4	-	-	49° 3'	φ11.8	9.0
M1S 25 – 2306		25	φ25	φ26.41	23	φ 6	φ20	8	13	14.7	11.21	5.3	-	-	-	48°51'	φ15.0	33.2
M1S 25 * 2308		25	φ25	φ26.41	23	φ 8	φ20	8	13	14.7	11.21	5.3	-	2-M4	4	48°51'	φ15.0	30.0
M1S 25 * 2310		25	φ25	φ26.41	23	φ10	φ20	8	13	14.7	11.21	5.3	-	2-M4	4	48°51'	φ15.0	27.3
M1S 30 – 2608		30	φ30	φ31.41	26	φ 8	φ22	8.9	14.5	15.89	11.71	6.2	-	-	-	47°42'	φ19.4	46.4
M1S 30 * 2608		30	φ30	φ31.41	26	φ 8	φ22	8.9	14.5	15.89	11.71	6.2	-	2-M5	4.5	47°42'	φ19.4	44.7
M1S 30 * 2610		30	φ30	φ31.41	26	φ10	φ22	8.9	14.5	15.89	11.71	6.2	-	2-M5	4.5	47°42'	φ19.4	41.8
M1S 30 * 2612		30	φ30	φ31.41	26	φ12	φ22	8.9	14.5	15.89	11.71	6.2	-	2-M5	4.5	47°42'	φ19.4	38.3
M1S 30 – 2008		30	φ30	φ31.41	20	φ 8	φ22	2.9	8.5	9.89	5.71	6.2	-	-	-	47°42'	φ19.4	30.9
M1.25S 20 – 2408		20	φ25	φ26.77	24	φ 8	φ20	8.99	14	16	12.38	5.5	-	-	-	49° 3'	φ14.4	33.1
M1.25S 30 – 3210		30	φ37.5	φ39.27	32	φ10	φ28	10	17	18.85	14.13	7	-	-	-	47°42'	φ25.2	88.6
M1.5S 20 – 2810		20	φ30	φ32.12	28	φ10	φ24	10	16.5	18.53	14.06	6.8	-	-	-	49° 3'	φ17.7	54.9
M1.5S 20 – 2110		20	φ30	φ32.12	21	φ10	φ24	3	9	11	7.06	6	-	-	-	49° 3'	φ19.0	32.8
M1.5S 25 – 3410		25	φ37.5	φ39.62	34	φ10	φ30	11.5	19	21.26	16.31	7.5	-	-	-	48°51'	φ23.7	106.5
M1.5S 30 – 3812		30	φ45	φ47.12	38	φ12	φ33	12.34	21	22.83	16.56	9.3	-	-	-	47°42'	φ29.6	152.0
For all the weight values below, the unit is kg.																		
M2S 20 – 3712	1 : 1	20	φ40	<sup>(φ42.83)</sup> φ41.32	37	φ12	φ34	14	21	24	18.41	8.5	-	-	-	49° 3'	φ23.9	0.14
M2S 20 – 2812		20	φ40	<sup>(φ42.83)</sup> φ41.32	28	φ12	φ34	5	12	15	9.41	8.5	-	-	-	49° 3'	φ23.9	0.09
M2S 25 – 4012		25	φ50	<sup>(φ52.83)</sup> φ51.33	40	φ12	φ42	10.99	21	23.34	16.41	10.5	-	-	-	48°51'	φ32.3	0.23
M2S 30 – 5116		30	φ60	<sup>(φ62.83)</sup> φ61.36	51	φ16	φ44	16.79	28	30.77	22.41	12.4	-	-	-	47°42'	φ38.9	0.36
M2.5S 20 – 4814		20	φ50	<sup>(φ53.54)</sup> φ51.66	48	φ14	φ42	19	28	32.06	24.77	11.1	-	-	-	49° 3'	φ28.5	0.30
M2.5S 20 – 3514		20	φ50	<sup>(φ53.54)</sup> φ51.66	35	φ14	φ42	6	15	19.06	11.77	11.1	-	-	-	49° 3'	φ28.5	0.17
M2.5S 25 – 5016		25	φ62.5	<sup>(φ66.04)</sup> φ64.16	50	φ16	φ52	13.5	27	29.42	20.52	13.5	-	-	-	48°51'	φ40.8	0.44
M2.5S 30 – 6318		30	φ75	<sup>(φ78.54)</sup> φ76.7	63	φ18	φ55	20.5	34.5	37.71	27.27	15.5	-	-	-	47°42'	φ49.1	0.71
M2.5S 30 – 5016		30	φ75	<sup>(φ78.54)</sup> φ76.7	50	φ16	φ55	7.5	21.5	24.71	14.27	15.5	-	-	-	47°42'	φ49.1	0.51
M3S 20 – 5816		20	φ60	<sup>(φ64.24)</sup> φ61.99	58	φ16	φ50	23	35	39.06	30.12	13.6	-	-	-	49° 3'	φ35.5	0.52
M3S 20 – 4216		20	φ60	<sup>(φ64.24)</sup> φ61.99	42	φ16	φ50	7	19	23.06	14.12	13.6	-	-	-	49° 3'	φ35.5	0.30
M4S 20 – 7520		20	φ80	<sup>(φ85.66)</sup> φ82.65	75	φ20	φ64	27	45	50.05	37.83	18.6	-	-	-	49° 3'	φ47.3	1.14

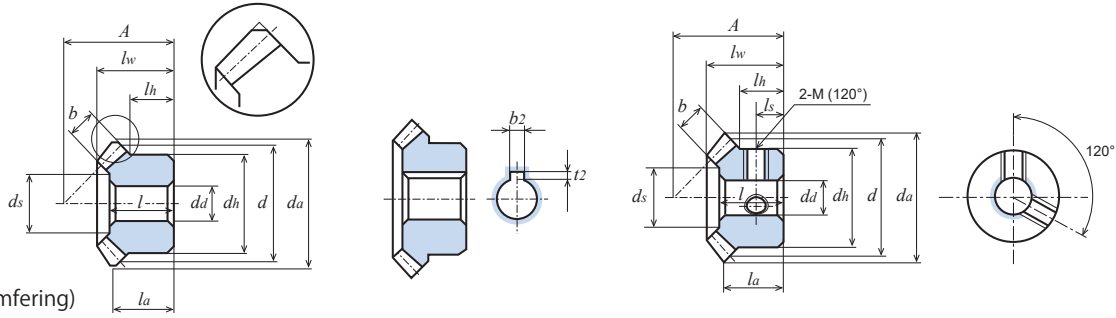

Fig. 1 (Tip chamfering)

Allowable transfer capability for different revolutions per minute Bending strength (Unit: W)							Allowable transfer capability for different revolutions per minute Surface durability (Unit: W)							Backlash (Unit: mm)	Catalogue number
10 rpm	100 rpm	200 rpm	400 rpm	600 rpm	800 rpm	1,000 rpm	10 rpm	100 rpm	200 rpm	400 rpm	600 rpm	800 rpm	1,000 rpm		
0.1	1.5	3.1	6.2	9.3	12.4	15.5	-	-	-	-	-	-	-	0.02 to 0.08	M50S 20 – 1103 M50S 20 * 1103
0.2	2.5	5.0	10.0	15.0	20.1	25.1	-	-	-	-	-	-	-	0.02 to 0.08	M50S 25 – 1204 M50S 25 * 1204
0.3	3.8	7.6	15.2	22.9	30.5	38.1	-	-	-	-	-	-	-	0.02 to 0.08	M50S 30 – 1404 M50S 30 * 1404
0.6	6.0	12.1	24.2	36.3	48.4	60.6	-	-	-	-	-	-	-	0.02 to 0.08	M80S 20 – 1605 M80S 20 * 1605
1.0	10.3	20.6	41.3	61.9	82.6	103.3	-	-	-	-	-	-	-	0.02 to 0.08	M80S 25 – 1805
1.0	10.5	21.2	42.3	63.5	84.7	104.7	-	-	-	-	-	-	-	0.05 to 0.12	M1S 20 – 2106 M1S 20 * 2106 M1S 20 * 2108
1.0	10.5	21.2	42.3	63.5	84.7	104.7	-	-	-	-	-	-	-	0.05 to 0.12	M1S 20 – 1406 M1S 20 = 1408
1.7	17.5	35.0	70.0	105.0	139.9	169.1	-	-	-	-	-	-	-	0.05 to 0.12	M1S 25 – 2306 M1S 25 * 2308 M1S 25 * 2310
2.6	26.2	52.4	104.7	157.2	202.7	241.9	-	-	-	-	-	-	-	0.05 to 0.12	M1S 30 – 2608 M1S 30 * 2608 M1S 30 * 2610 M1S 30 * 2612
2.6	26.2	52.4	104.7	157.2	202.7	241.9	-	-	-	-	-	-	-	0.05 to 0.12	M1S 30 – 2008
2.0	20.9	41.9	83.9	125.9	167.1	206.7	-	-	-	-	-	-	-	0.05 to 0.12	M1.25S 20 – 2408
4.6	46.9	93.9	187.7	274.3	347.8	414.3	-	-	-	-	-	-	-	0.05 to 0.12	M1.25S 30 – 3210
3.7	37.1	74.4	148.9	223.3	287.6	344.7	0.2	2.8	5.7	11.7	18.1	23.4	27.6	0.05 to 0.12	M1.5S 20 – 2810
3.3	33.5	67.0	134.1	201.1	259.2	310.8	0.2	2.6	5.3	10.6	15.5	20.8	25.1	0.05 to 0.12	M1.5S 20 – 2110
5.6	56.5	113.1	226.3	331.5	419.3	499.1	0.5	5.1	10.5	21.3	31.4	40.2	48.4	0.05 to 0.12	M1.5S 25 – 3410
8.8	88.3	176.7	353.5	501.8	630.0	744.7	0.9	9.5	19.1	38.7	55.6	70.7	84.4	0.05 to 0.12	M1.5S 30 – 3812
For all the values below, the unit is kW.															
0.008	0.083	0.167	0.334	0.484	0.611	0.726	0.0006	0.006	0.013	0.027	0.040	0.051	0.061	0.05 to 0.12	M2S 20 – 3712
0.008	0.083	0.167	0.334	0.484	0.611	0.726	0.0006	0.006	0.013	0.027	0.040	0.051	0.061	0.05 to 0.12	M2S 20 – 2812
0.013	0.139	0.279	0.554	0.777	0.971	1.143	0.001	0.013	0.026	0.054	0.076	0.097	0.115	0.05 to 0.12	M2S 25 – 4012
0.020	0.209	0.418	0.809	1.121	1.388	1.637	0.002	0.023	0.047	0.092	0.129	0.163	0.195	0.05 to 0.12	M2S 30 – 5116
0.016	0.169	0.338	0.672	0.941	1.177	1.385	0.001	0.013	0.028	0.056	0.080	0.101	0.121	0.06 to 0.15	M2.5S 20 – 4814
0.016	0.169	0.338	0.672	0.941	1.177	1.385	0.001	0.013	0.028	0.056	0.080	0.101	0.121	0.06 to 0.15	M2.5S 20 – 3514
0.027	0.279	0.558	1.069	1.480	1.829	2.171	0.002	0.027	0.055	0.107	0.150	0.189	0.229	0.06 to 0.15	M2.5S 25 – 5016
0.040	0.408	0.817	1.517	2.070	2.557	3.109	0.004	0.046	0.094	0.177	0.247	0.312	0.387	0.06 to 0.15	M2.5S 30 – 6318
0.040	0.408	0.817	1.517	2.070	2.557	3.109	0.004	0.046	0.094	0.177	0.247	0.312	0.387	0.06 to 0.15	M2.5S 30 – 5016
0.029	0.297	0.594	1.148	1.591	1.971	2.323	0.002	0.025	0.050	0.098	0.139	0.175	0.209	0.06 to 0.15	M3S 20 – 5816
0.029	0.297	0.594	1.148	1.591	1.971	2.323	0.002	0.025	0.050	0.098	0.139	0.175	0.209	0.06 to 0.15	M3S 20 – 4216
0.071	0.719	1.438	2.634	3.577	4.465	5.421	0.006	0.062	0.126	0.236	0.327	0.418	0.516	0.06 to 0.15	M4S 20 – 7520



2D • 3D CAD

# M: Hardened

# Straight Miter (S45C)

Module 1.5/2/2.5/3/4

Gear Ratio 1 : 1



Unit: mm

Accuracy Class	Material	Pressure angle	Heat treatment	Tooth surface hardness	Backlash ①
[JIS B 1704] 4	S45C	20°	Induction hardening of teeth	HRC47 to 53	See the table below.

- ★ No surface treatment is applied.
- ★ This allowable transfer capability table was prepared by using the formulas presented by the JGMA (Japan Gear Manufacturers Association). For the unit conversion method, refer to P. 20 in "References."
- ★ Gears with a [#] are provided with key grooves, keys, two screw holes, and two set screws, and gears with a [=] are provided with key grooves and keys.
- ★ The values in parentheses below "Tip diameter da" are theoretical values. The actual maximum diameter is the value obtained after the teeth are chamfered parallel to the shaft center. (See Fig. 1.)

① This is a theoretical value obtained when a pair of gears of the same type and material are meshed with each other.

Catalogue number	Gear ratio	Number of teeth	Reference diameter	Tip diameter	As-sembly distance	Hole diameter	Hub diameter	Hub length	Hole length	Over-all length	Dis-tance from end face to tip	Face width	Key groove	Screw		Tip angle	Counter-bore diameter (Reference value)	Weight
														2-M	ls			
M1.5S 20 – 2810H	1 : 1	20	φ 30	φ32.12	28	φ10	φ24	10	16.5	18.53	14.06	6.8	-	-	-	49° 3'	φ17.7	54.9
M1.5S 20 # 2810H		20	φ 30	φ32.12	28	φ10	φ24	10	16.5	18.53	14.06	6.8	3 × 1.4	2-M4	5	49° 3'	φ17.7	53.7
M1.5S 20 # 2812H		20	φ 30	φ32.12	28	φ12	φ24	10	16.5	18.53	14.06	6.8	4 × 1.8	2-M4	5	49° 3'	φ17.7	49.0
M1.5S 20 – 2110H		20	φ 30	φ32.12	21	φ10	φ24	3	9	11	7.06	6	-	-	-	49° 3'	φ19.0	32.8
M1.5S 20 = 2110H		20	φ 30	φ32.12	21	φ10	φ24	3	9	11	7.06	6	3 × 1.4	-	-	49° 3'	φ19.0	32.5
M1.5S 25 – 3410H		25	φ 37.5	φ39.62	34	φ10	φ30	11.5	19	21.26	16.31	7.5	-	-	-	48°51'	φ23.7	106.5
M1.5S 30 – 3812H		30	φ 45	φ47.12	38	φ12	φ33	12.34	21	22.83	16.56	9.3	-	-	-	47°42'	φ29.6	152.0
M1.5S 30 # 3812H		30	φ 45	φ47.12	38	φ12	φ33	12.34	21	22.83	16.56	9.3	4 × 1.8	2-M4	6.5	47°42'	φ29.6	150.1
M1.5S 30 # 3815H		30	φ 45	φ47.12	38	φ15	φ33	12.34	21	22.83	16.56	9.3	5 × 2.3	2-M4	6.5	47°42'	φ29.6	139.0
For all the weight values below, the unit is kg.																		
M2S 20 – 3712H	1 : 1	20	φ 40	φ41.32 <sup>(φ42.83)</sup>	37	φ12	φ34	14	21	24	18.41	8.5	-	-	-	49° 3'	φ23.9	0.14
M2S 20 # 3712H		20	φ 40	φ41.32 <sup>(φ42.83)</sup>	37	φ12	φ34	14	21	24	18.41	8.5	4 × 1.8	2-M5	7	49° 3'	φ23.9	0.14
M2S 20 # 3715H		20	φ 40	φ41.32 <sup>(φ42.83)</sup>	37	φ15	φ34	14	21	24	18.41	8.5	5 × 2.3	2-M5	7	49° 3'	φ23.9	0.13
M2S 20 – 2812H		20	φ 40	φ41.32 <sup>(φ42.83)</sup>	28	φ12	φ34	5	12	15	9.41	8.5	-	-	-	49° 3'	φ23.9	0.085
M2S 20 = 2812H		20	φ 40	φ41.32 <sup>(φ42.83)</sup>	28	φ12	φ34	5	12	15	9.41	8.5	4 × 1.8	-	-	49° 3'	φ23.9	0.084
M2S 20 = 2816H		20	φ 40	φ41.32 <sup>(φ42.83)</sup>	28	φ16	φ34	5	12	15	9.41	8.5	5 × 2.3	-	-	49° 3'	φ23.9	0.076
M2S 25 – 4012H		25	φ 50	φ51.33 <sup>(φ52.83)</sup>	40	φ12	φ42	10.99	21	23.34	16.41	10.5	-	-	-	48°51'	φ32.3	0.23
M2S 30 – 5116H		30	φ 60	φ61.36 <sup>(φ62.83)</sup>	51	φ16	φ44	16.79	28	30.77	22.41	12.4	-	-	-	47°42'	φ38.9	0.36
M2S 30 # 5120H		30	φ 60	φ61.36 <sup>(φ62.83)</sup>	51	φ20	φ44	16.79	28	30.77	22.41	12.4	6 × 2.8	2-M5	8.5	47°42'	φ38.9	0.33
M2.5S 20 – 4814H		20	φ 50	φ51.66 <sup>(φ53.54)</sup>	48	φ14	φ42	19	28	32.06	24.77	11.1	-	-	-	49° 3'	φ28.5	0.29
M2.5S 20 # 4815H		20	φ 50	φ51.66 <sup>(φ53.54)</sup>	48	φ15	φ42	19	28	32.06	24.77	11.1	5 × 2.3	2-M5	9.5	49° 3'	φ28.5	0.29
M2.5S 20 # 4816H		20	φ 50	φ51.66 <sup>(φ53.54)</sup>	48	φ16	φ42	19	28	32.06	24.77	11.1	5 × 2.3	2-M5	9.5	49° 3'	φ28.5	0.28
M2.5S 20 # 4818H		20	φ 50	φ51.66 <sup>(φ53.54)</sup>	48	φ18	φ42	19	28	32.06	24.77	11.1	6 × 2.8	2-M5	9.5	49° 3'	φ28.5	0.27
M2.5S 20 # 4820H		20	φ 50	φ51.66 <sup>(φ53.54)</sup>	48	φ20	φ42	19	28	32.06	24.77	11.1	6 × 2.8	2-M5	9.5	49° 3'	φ28.5	0.25
M2.5S 20 – 3514H		20	φ 50	φ51.66 <sup>(φ53.54)</sup>	35	φ14	φ42	6	15	19.06	11.77	11.1	-	-	-	49° 3'	φ28.5	0.17
M2.5S 20 = 3515H		20	φ 50	φ51.66 <sup>(φ53.54)</sup>	35	φ15	φ42	6	15	19.06	11.77	11.1	5 × 2.3	-	-	49° 3'	φ28.5	0.16
M2.5S 20 = 3518H		20	φ 50	φ51.66 <sup>(φ53.54)</sup>	35	φ18	φ42	6	15	19.06	11.77	11.1	6 × 2.8	-	-	49° 3'	φ28.5	0.16
M2.5S 20 = 3520H		20	φ 50	φ51.66 <sup>(φ53.54)</sup>	35	φ20	φ42	6	15	19.06	11.77	11.1	6 × 2.8	-	-	49° 3'	φ28.5	0.15
M2.5S 25 – 5016H	25	φ 62.5	φ64.16 <sup>(φ66.04)</sup>	50	φ16	φ52	13.5	27	29.42	20.52	13.5	-	-	-	48°51'	φ40.8	0.44	
M2.5S 30 – 6318H	30	φ 75	φ76.7 <sup>(φ78.54)</sup>	63	φ18	φ55	20.5	34.5	37.71	27.27	15.5	-	-	-	47°42'	φ49.1	0.71	
M2.5S 30 – 5016H	30	φ 75	φ76.7 <sup>(φ78.54)</sup>	50	φ16	φ55	7.5	21.5	24.71	14.27	15.5	-	-	-	47°42'	φ49.1	0.50	
M3S 20 – 5816H	20	φ 60	φ61.99 <sup>(φ64.24)</sup>	58	φ16	φ50	23	35	39.06	30.12	13.6	-	-	-	49° 3'	φ35.5	0.52	
M3S 20 # 5820H	20	φ 60	φ61.99 <sup>(φ64.24)</sup>	58	φ20	φ50	23	35	39.06	30.12	13.6	6 × 2.8	2-M6	11.5	49° 3'	φ35.5	0.49	
M3S 20 # 5825H	20	φ 60	φ61.99 <sup>(φ64.24)</sup>	58	φ25	φ50	23	35	39.06	30.12	13.6	8 × 3.3	2-M6	11.5	49° 3'	φ35.5	0.43	
M3S 20 = 4220H	20	φ 60	φ61.99 <sup>(φ64.24)</sup>	42	φ20	φ50	7	19	23.06	14.12	13.6	6 × 2.8	-	-	49° 3'	φ35.5	0.28	
M3S 25 – 6020H	25	φ 75	φ77 <sup>(φ79.24)</sup>	60	φ20	φ65	17.5	32	35.31	24.62	16.2	-	-	-	48°51'	φ48.1	0.79	
M3S 30 – 7522H	30	φ 90	φ92.04 <sup>(φ94.24)</sup>	75	φ22	φ66	23.64	40	44.65	32.12	18.6	-	-	-	47°42'	φ57.3	1.20	
M3S 30 # 7530H	30	φ 90	φ92.04 <sup>(φ94.24)</sup>	75	φ30	φ66	23.64	40	44.65	32.12	18.6	8 × 3.3	2-M6	12	47°42'	φ57.3	1.09	
M4S 20 – 7520H	20	φ 80	φ82.65 <sup>(φ85.66)</sup>	75	φ20	φ64	27	45	50.05	37.83	18.6	-	-	-	49° 3'	φ47.3	1.14	

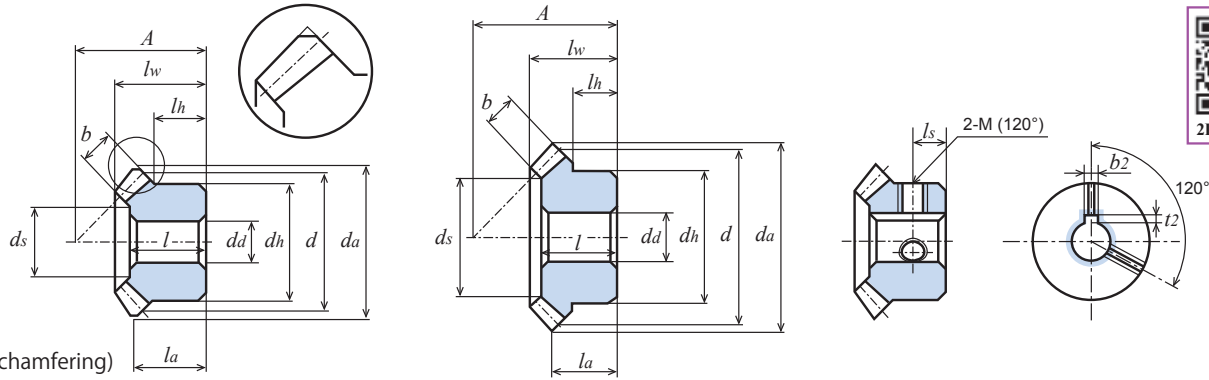

Fig. 1 (Tip chamfering)

Allowable transfer capability for different revolutions per minute Bending strength (Unit: W)							Allowable transfer capability for different revolutions per minute Surface durability (Unit: W)							Backlash (Unit: mm)	Catalogue number
10 rpm	100 rpm	200 rpm	400 rpm	600 rpm	800 rpm	1,000 rpm	10 rpm	100 rpm	200 rpm	400 rpm	600 rpm	800 rpm	1,000 rpm		
3.4	34.4	68.9	137.8	206.7	267.0	321.6	0.7	8.0	16.5	34.0	52.0	68.0	82.8	0.05 to 0.12	M1.5S 20 – 2810H M1.5S 20 # 2810H M1.5S 20 # 2812H
3.1	31.7	63.5	127.0	190.5	246.2	296.4	0.6	7.4	15.2	31.4	48.0	62.8	76.4	0.05 to 0.12	M1.5S 20 – 2110H M1.5S 20 = 2110H
5.3	53.6	107.2	214.4	314.6	400.3	478.5	1.3	14.7	30.4	62.7	93.6	120.6	145.6	0.05 to 0.12	M1.5S 25 – 3410H
8.3	83.2	166.5	333.1	475.1	599.9	712.1	2.3	26.4	54.5	112.5	163.3	208.9	250.4	0.05 to 0.12	M1.5S 30 – 3812H M1.5S 30 # 3812H M1.5S 30 # 3815H
For all the values below, the unit is kW.															
0.007	0.078	0.156	0.313	0.455	0.578	0.689	0.001	0.018	0.038	0.079	0.117	0.151	0.182	0.05 to 0.12	M2S 20 – 3712H M2S 20 # 3712H M2S 20 # 3715H
0.007	0.078	0.156	0.313	0.455	0.578	0.689	0.001	0.018	0.038	0.079	0.117	0.151	0.182	0.05 to 0.12	M2S 20 – 2812H M2S 20 = 2812H M2S 20 = 2816H
0.013	0.131	0.262	0.522	0.735	0.923	1.091	0.003	0.037	0.076	0.156	0.224	0.285	0.340	0.05 to 0.12	M2S 25 – 4012H
0.019	0.197	0.394	0.765	1.066	1.328	1.564	0.005	0.064	0.132	0.265	0.376	0.474	0.564	0.05 to 0.12	M2S 30 – 5116H M2S 30 # 5120H
0.015	0.157	0.314	0.626	0.881	1.108	1.309	0.003	0.038	0.079	0.162	0.232	0.295	0.353	0.06 to 0.15	M2.5S 20 – 4814H M2.5S 20 # 4815H M2.5S 20 # 4816H M2.5S 20 # 4818H M2.5S 20 # 4820H
0.015	0.157	0.314	0.626	0.881	1.108	1.309	0.003	0.038	0.079	0.162	0.232	0.295	0.353	0.06 to 0.15	M2.5S 20 – 3514H M2.5S 20 = 3515H M2.5S 20 = 3518H M2.5S 20 = 3520H
0.026	0.261	0.522	1.005	1.398	1.737	2.051	0.006	0.075	0.154	0.307	0.435	0.547	0.653	0.06 to 0.15	M2.5S 25 – 5016H
0.038	0.385	0.771	1.439	1.978	2.444	2.905	0.011	0.128	0.264	0.509	0.712	0.891	1.069	0.06 to 0.15	M2.5S 30 – 6318H
0.038	0.385	0.771	1.439	1.978	2.444	2.905	0.011	0.128	0.264	0.509	0.712	0.891	1.069	0.06 to 0.15	M2.5S 30 – 5016H
0.027	0.275	0.551	1.068	1.489	1.854	2.184	0.006	0.068	0.140	0.281	0.398	0.503	0.598	0.06 to 0.15	M3S 20 – 5816H M3S 20 # 5820H M3S 20 # 5825H
0.027	0.275	0.551	1.068	1.489	1.854	2.184	0.006	0.068	0.140	0.281	0.398	0.503	0.598	0.06 to 0.15	M3S 20 = 4220H
0.045	0.451	0.902	1.684	2.315	2.861	3.400	0.011	0.131	0.272	0.523	0.732	0.916	1.100	0.06 to 0.15	M3S 25 – 6020H
0.066	0.666	1.332	2.399	3.254	4.056	4.784	0.020	0.225	0.464	0.862	1.190	1.502	1.790	0.06 to 0.15	M3S 30 – 7522H M3S 30 # 7530H
0.066	0.663	1.327	2.448	3.349	4.150	4.920	0.015	0.168	0.347	0.660	0.920	1.154	1.382	0.06 to 0.15	M4S 20 – 7520H



Unit: mm

Accuracy Class	Material	Pressure angle	Heat treatment	Tooth surface hardness	Backlash ①	Number of teeth of all gears
[JIS B 1704] 4	S45C	20°	Induction hardening of teeth	HRC47 to 53	See the table below.	20

- ★ No surface treatment is applied. Gears with a [=] are provided with key grooves and keys. ① This is a theoretical value obtained when a pair of gears of the same type and material are meshed with each other.
- ★ This allowable transfer capability table was prepared by using the formulas presented by the JGMA (Japan Gear Manufacturers Association). For the unit conversion method, refer to P. 20 in "References."
- ★ The values in parentheses below "Tip diameter  $d_a$ " are theoretical values. The actual maximum diameter is the value obtained after the teeth are chamfered parallel to the shaft center.
- ★ For the MGH Series, the teeth have been finished by induction hardening and the holes have been finished by grinding. Also, keys and set screws are provided. This product can be used without additional machining. (See Fig. 1.)

Catalogue number	Gear ratio	Module	Reference diameter	Tip diameter	Assembly distance	Hole diameter	Hub diameter	Hub length	Hole length	Overall length	Distance from end face to tip	Face width	Key groove	Screw		Tip angle	Weight
														$M$	$l_s$		
	$u$	$m$	$d$	$d_a$	$A$	$d_a(\text{H7})$	$d_h$	$l_h$	$l$	$l_w$	$l_a$	$b$	$b_2 \times t_2$				
<b>MGH = 18</b>	1 : 1	2.5	$\phi$ 50	$\phi$ 51.66 <sup>(<math>\phi</math>53.54)</sup>	50	$\phi$ 18	$\phi$ 40	20	30	33.54	26.77	10.3	6 × 2.8	M6	10	49° 3'	0.26
<b>MGH = 20</b>		2.75	$\phi$ 55	$\phi$ 56.82 <sup>(<math>\phi</math>58.89)</sup>	54	$\phi$ 20	$\phi$ 44	21	32	35.54	28.45	10.8	6 × 2.8	M6	10.5	49° 3'	0.34
<b>MGH = 22</b>		3	$\phi$ 60	$\phi$ 61.99 <sup>(<math>\phi</math>64.24)</sup>	58	$\phi$ 22	$\phi$ 48	22	34	38.01	30.12	12	6 × 2.8	M6	11	49° 3'	0.43
<b>MGH = 25A</b>		3	$\phi$ 60	$\phi$ 61.99 <sup>(<math>\phi</math>64.24)</sup>	58	$\phi$ 25	$\phi$ 48	22	34	38.01	30.12	12	8 × 3.3	M8	11	49° 3'	0.40

- CONTENTS
- INFORMATION
- GEARBOXES
- ANTI-BACKLASH SPUR GEARS
- SPUR GEARS
- RACKS
- HELICAL GEARS AND SCREW GEARS
- MITER GEARS
- BEVEL GEARS
- WORMS AND WORM WHEELS
- REFERENCES

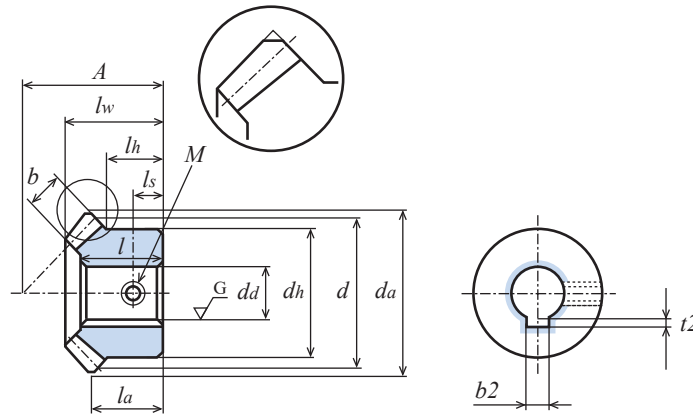
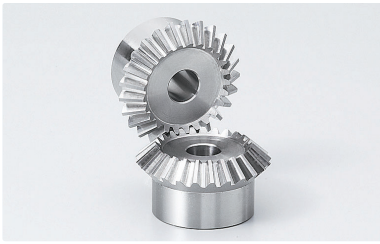

Fig. 1 (Tip chamfering)

Allowable transfer capability for different revolutions per minute Bending strength (Unit: kW)							Allowable transfer capability for different revolutions per minute Surface durability (Unit: kW)							Backlash (Unit: mm)	Catalogue number
10 rpm	100 rpm	200 rpm	400 rpm	600 rpm	800 rpm	1,000 rpm	10 rpm	100 rpm	200 rpm	400 rpm	600 rpm	800 rpm	1,000 rpm		
0.014	0.143	0.287	0.575	0.825	0.985	1.180	0.003	0.036	0.075	0.154	0.221	0.281	0.335	0.06 to 0.15	<b>MGH = 18</b>
0.018	0.186	0.373	0.743	1.016	1.273	1.509	0.004	0.047	0.097	0.198	0.282	0.358	0.426	0.06 to 0.15	<b>MGH = 20</b>
0.024	0.246	0.492	0.952	1.324	1.655	1.951	0.005	0.061	0.125	0.251	0.356	0.450	0.533	0.06 to 0.15	<b>MGH = 22</b>
0.024	0.246	0.492	0.952	1.324	1.655	1.951	0.005	0.061	0.125	0.251	0.356	0.450	0.533	0.06 to 0.15	<b>MGH = 25A</b>





Unit: mm

Accuracy Class	Material	Pressure angle	Heat treatment	Tooth surface hardness	Backlash ①
[JIS B 1704] 4	SUS304	20°	—	—	See the table below.

★ No surface treatment is applied. ① This is a theoretical value obtained when a pair of gears of the same type and material are meshed with each other.

★ This allowable transfer capability table was prepared by using the formulas presented by the JGMA (Japan Gear Manufacturers Association). For the unit conversion method, refer to P. 20 in "References."

★ Gears with a [\*] are provided with two screw holes. No set screws are provided.

★ The values in parentheses below "Tip diameter  $d_a$ " are theoretical values. The actual maximum diameter is the value obtained after the teeth are chamfered parallel to the shaft center. (See Fig. 1.)

Catalogue number	Gear ratio	Number of teeth	Reference diameter	Tip diameter	As-sembly distance	Hole diameter	Hub diameter	Hub length	Hole length	Overall length	Distance from end face to tip	Face width	Screw		Tip angle	Counterbore diameter (Reference value)	Weight	
													2-M(120°)	ls				
M80SU 20 — 1605	1 : 1	20	φ16	φ17.13	16	φ 5	φ12	6	10	11	8.57	3.7	-	-	49° 3'	φ 9.5	8.9	
M80SU 20 * 1605		20	φ16	φ17.13	16	φ 5	φ12	6	10	11	8.57	3.7	2-M3	3	49° 3'	φ 9.5	8.5	
M80SU 25 — 1805		25	φ20	φ21.13	18	φ 5	φ16	6	10.5	11.67	11.67	8.57	4.7	-	-	48°51'	φ11.7	17.3
M80SU 25 * 1805		25	φ20	φ21.13	18	φ 5	φ16	6	10.5	11.67	11.67	8.57	4.7	2-M3	3	48°51'	φ11.7	16.8
M80SU 30 — 2006		30	φ24	φ25.13	20	φ 6	φ18	6	11	12.34	12.34	8.57	5.6	-	-	47°42'	φ14.1	24.8
M15SU 20 — 2106		20	φ20	φ21.41	21	φ 6	φ16	9	13	14.53	14.53	11.71	4.3	-	-	49° 3'	φ11.8	19.9
M15SU 20 * 2106		20	φ20	φ21.41	21	φ 6	φ16	9	13	14.53	14.53	11.71	4.3	2-M4	4.5	49° 3'	φ11.8	19.1
M15SU 25 — 2306		25	φ25	φ26.41	23	φ 6	φ20	8	13	14.70	14.70	11.21	5.3	-	-	48°51'	φ15.0	34.1
M15SU 25 * 2306		25	φ25	φ26.41	23	φ 6	φ20	8	13	14.70	14.70	11.21	5.3	2-M4	4	48°51'	φ15.0	32.9
M15SU 30 — 2608		30	φ30	φ31.41	26	φ 8	φ22	8.9	14.5	15.89	15.89	11.71	6.2	-	-	47°42'	φ19.4	47
M15SU 30 * 2608		30	φ30	φ31.41	26	φ 8	φ22	8.9	14.5	15.89	15.89	11.71	6.2	2-M5	4.5	47°42'	φ19.4	45.2
M1.5SU 20 — 2810		20	φ30	φ32.12	28	φ10	φ24	10	16.5	18.53	18.53	14.06	6.8	-	-	49° 3'	φ17.7	55.4
M1.5SU 25 — 3410		25	φ37.5	φ39.62	34	φ10	φ30	11.5	19	21.26	21.26	16.31	7.5	-	-	48°51'	φ23.7	107.6
M1.5SU 30 — 3812		30	φ45	φ47.12	38	φ12	φ33	12.34	21	22.83	22.83	16.56	9.3	-	-	47°42'	φ29.6	153.6
M2SU 20 — 3712		20	φ40	φ41.32 <sup>(φ42.83)</sup>	37	φ12	φ34	14	21	24	24	18.41	8.5	-	-	49° 3'	φ23.9	142.5
M2SU 25 — 4012		25	φ50	φ51.33 <sup>(φ52.83)</sup>	40	φ12	φ42	11	21	23.34	23.34	17.07	10.5	-	-	48°51'	φ32.3	229.6
M2SU 30 — 5116		30	φ60	φ61.36 <sup>(φ62.83)</sup>	51	φ16	φ44	16.79	28	30.77	30.77	22.41	12.4	-	-	47°42'	φ38.9	364.9
M3SU 20 — 5816		20	φ60	φ61.99 <sup>(φ64.24)</sup>	58	φ16	φ50	23	35	39.06	39.06	30.12	13.6	-	-	49° 3'	φ35.5	525.6

## M: Metal-Injection-Molded (MIM)

## Straight Miter (SUS304L)

### Module 0.5/0.8/1

### Gear Ratio 1 : 1



Unit: mm

Accuracy Class	Material	Pressure angle	Heat treatment	Tooth surface hardness	Backlash ①
—	SUS304L	20°	—	—	See the table below.

★ No surface treatment is applied. This allowable transfer capability table was prepared by using the formulas presented by the JGMA (Japan Gear Manufacturers Association). For the unit conversion method, refer to P. 20 in "References."

★ Gears with a [\*] are provided with two screw holes. No set screws are provided.

① This is a theoretical value obtained when a pair of gears of the same type and material are meshed with each other.

★ The module size is a nominal value. The dimensions vary slightly depending on the molding shrinkage rate.

This product must be used with a MIM miter gear. This product cannot be used with products of other series.

★ Cautions on additional machining: Hold the tip circle with a chuck. Failure to do so may cause air bubble blowholes.

Catalogue number	Gear ratio	Module	Number of teeth	Reference diameter	Tip diameter	As-sembly distance	Hole diameter	Hub diameter	Hub length	Overall length	Distance from end face to tip	Face width	Screw		Tip angle	Weight
													2-M(120°)	ls		
M50SUM 20 * 1103	1 : 1	0.5	20	φ10	φ10.70	11	φ3	φ 8	4.25	8	6.35	2.5	2-M2.5	2.5	49°48'	2.6
M80SUM 20 * 1605		0.8	20	φ16	φ17.13	16	φ5	φ12	4.5	10.96	8.57	3.7	2-M3	2.5	49°48'	10.2
M1SUM 20 * 2106		1.0	20	φ20	φ21.41	21	φ6	φ16	7.5	14.49	11.71	4.3	2-M4	4.5	49°48'	22.0

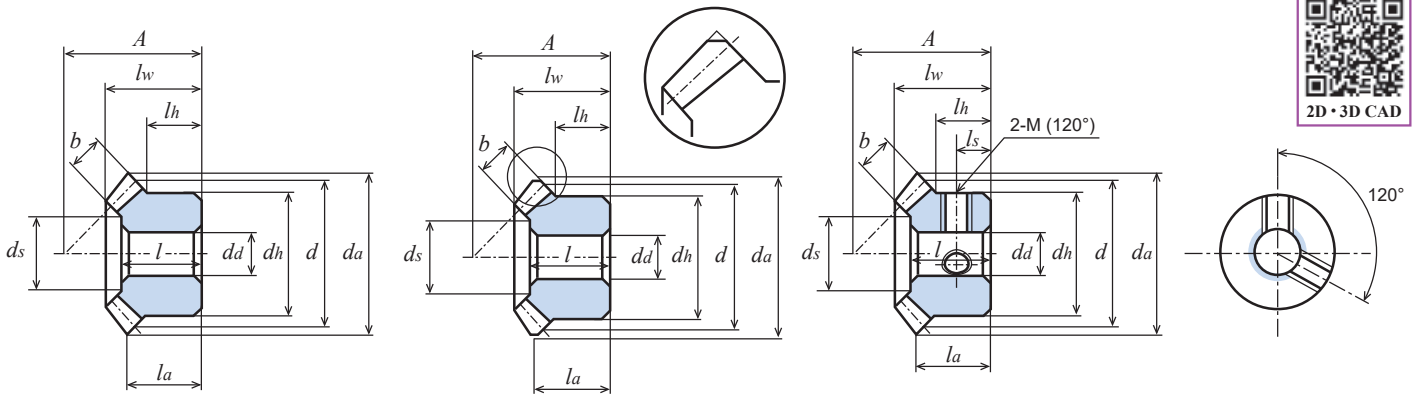

Fig. 1 (Tip chamfering)

Allowable transfer capability for different revolutions per minute Bending strength (Unit: W)							Backlash (Unit: mm)	Catalogue number
10 rpm	100 rpm	200 rpm	400 rpm	600 rpm	800 rpm	1,000 rpm		
0.2	2.7	5.5	11.0	16.5	22.0	27.5	0.02 to 0.08	M80SU 20 – 1605 M80SU 20 * 1605
0.4	4.6	9.3	18.7	28.1	37.5	46.6	0.02 to 0.08	M80SU 25 – 1805 M80SU 25 * 1805
0.7	7.1	14.2	28.4	42.6	56.8	68.6	0.02 to 0.08	M80SU 30 – 2006
0.5	5.1	10.2	20.5	30.8	41.1	51.0	0.05 to 0.12	M1SU 20 – 2106 M1SU 20 * 2106
0.8	8.5	17.1	34.3	51.5	68.3	82.4	0.05 to 0.12	M1SU 25 – 2306 M1SU 25 * 2306
1.2	12.8	25.6	51.3	77.0	99.3	119.2	0.05 to 0.12	M1SU 30 – 2608 M1SU 30 * 2608
1.7	17.9	35.8	71.7	107.6	138.6	166.4	0.05 to 0.12	M1.5SU 20 – 2810
2.7	27.9	55.8	111.6	163.5	207.2	246.7	0.05 to 0.12	M1.5SU 25 – 3410
4.3	43.3	86.7	173.4	246.3	309.5	365.9	0.05 to 0.12	M1.5SU 30 – 3812
4.0	40.8	81.6	163.2	236.5	298.9	355.1	0.05 to 0.12	M2SU 20 – 3712
6.7	67.0	134.0	268.0	402.1	536.1	670.1	0.05 to 0.12	M2SU 25 – 4012
10.2	102.7	205.5	397.2	550.3	681.6	803.6	0.05 to 0.12	M2SU 30 – 5116
14.3	143.5	287.0	554.6	768.4	951.7	1122.0	0.06 to 0.15	M3SU 20 – 5816

## M: Metal-Injection-Molded (MIM)

## Straight Miter (SUS304L)

### Module 0.5/0.8/1

### Gear Ratio 1 : 1

Strength comparison of each material		
Material	Strength comparison	
S45C	1	1.67
SUS304	0.6	1
MIM (SUS304L)	0.4	0.67

Allowable transfer capability for different revolutions per minute Bending strength (Unit: W)						Backlash (Unit: mm)	Catalogue number
100 rpm	200 rpm	400 rpm	600 rpm	800 rpm	1,000 rpm		
0.5	1.1	2.2	3.3	4.4	5.6	0.02 to 0.08	M50SUM 20 * 1103
2.1	4.3	8.7	13.1	17.5	21.9	0.02 to 0.08	M80SUM 20 * 1605
3.7	7.6	15.3	22.9	30.6	37.8	0.05 to 0.12	M1SUM 20 * 2106

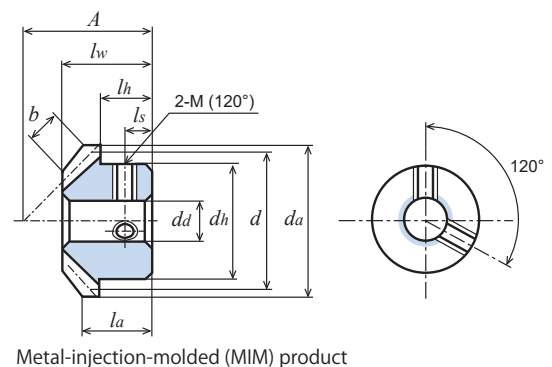

# M

## Straight Miter (Brass)

Module 0.5/0.8/1

Gear Ratio 1 : 1

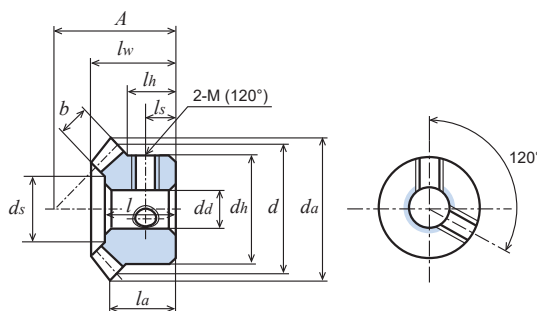

Unit: mm

Accuracy Class	Material	Pressure angle	Heat treatment	Tooth surface hardness	Backlash ①
[JIS B 1704] 4	C3604B	20°	—	—	See below ②

- ★ No surface treatment is applied. Gears with a [\*] are provided with two screw holes and set screws.
- ① This is a theoretical value obtained when a pair of gears of the same type and material are meshed with each other.
- ② The backlash is 0.02 mm to 0.08 mm when module 0.5 and 0.8, 0.05 mm to 0.12 mm when module 1.

Catalogue number	Gear ratio	Number of teeth	Reference diameter	Tip diameter	As-sembly distance	Hole diameter	Hub diameter	Hub length	Hole length	Over-all length	Distance from end face to tip	Face width	Screw		Tip angle	Counterbore diameter (Reference value)	Weight
													2-M(120°)	ls			
<b>M50B 20 — 1103</b>	1 : 1	20	φ10	φ10.71	11	φ3	φ 8	5	7	8	6.35	2.5	-	-	49° 3'	φ 4.9	2.9
<b>M50B 20 * 1103</b>		20	φ10	φ10.71	11	φ3	φ 8	5	7	8	6.35	2.5	2-M2.5	2.5	49° 3'	φ 4.9	2.7
<b>M50B 25 * 1204</b>		25	φ12.5	φ13.21	12	φ4	φ11	5	7	8.11	6.10	3.0	2-M3	3	48°14'	φ 6.5	4.9
<b>M80B 20 — 1605</b>		20	φ16	φ17.13	16	φ5	φ12	6	10	11	8.57	3.7	-	-	49° 3'	φ 9.5	9.4
<b>M80B 20 * 1605</b>		20	φ16	φ17.13	16	φ5	φ12	6	10	11	8.57	3.7	2-M3	3	49° 3'	φ 9.5	9.1
<b>M1B 20 * 2106</b>		20	φ20	φ21.41	21	φ6	φ16	9	13	14.53	11.71	4.3	2-M4	4.5	49° 3'	φ11.8	18.1
<b>M1B 25 * 2306</b>		25	φ25	φ26.41	23	φ6	φ20	8	13	14.70	11.21	5.3	2-M4	4	48°51'	φ15.0	31.5

# M

## Straight Miter (White POM)

Module 1

Gear Ratio 1 : 1

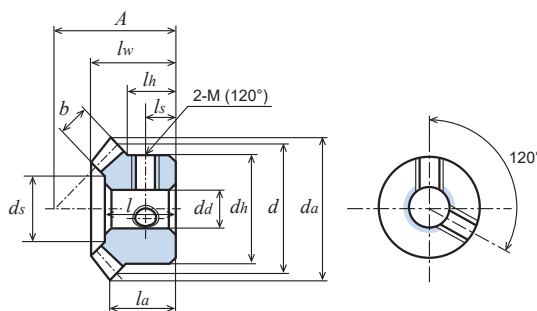

Unit: mm

Accuracy Class	Material	Pressure angle	Heat treatment	Tooth surface hardness	Backlash ①
—	White POM	20°	—	—	See the table below.

- ★ This is a machined product.
- ★ Because of the material characteristics, the dimensions and accuracy change with time and due to temperature changes.
- ★ The values in parentheses below "Tip diameter da" are theoretical values. The actual maximum diameter is the value obtained after the teeth are chamfered parallel to the shaft center.
- ① This is a theoretical value obtained when a pair of gears of the same type and material are meshed with each other.

Catalogue number	Gear ratio	Number of teeth	Reference diameter	Tip diameter	As-sembly distance	Hole diameter	Hub diameter	Hub length	Hole length	Over-all length	Distance from end face to tip	Face width	Screw		Tip angle	Counterbore diameter (Reference value)	Weight
													2-M(120°)	ls			
<b>M1D 25 * 2306</b>	1 : 1	25	φ25	φ26.41	23	φ6	φ20	8	13	14.70	11.21	5.3	2-M4	4	48°51'	φ15.0	5.2
<b>M1D 30 — 2608</b>		30	φ30	φ31.41	26	φ8	φ22	8.9	14.5	15.89	11.71	6.2	-	-	47°42'	φ19.4	8.3
<b>M1D 30 * 2608</b>		30	φ30	φ31.41	26	φ8	φ22	8.9	14.5	15.89	11.71	6.2	2-M4	4.5	47°42'	φ19.4	8.1

# M

## Straight Miter (Brass)

Module 0.5/0.8/1

Gear Ratio 1 : 1

CONTENTS

INFORMATION

GEARBOXES

ANTI-BACKLASH  
SPUR GEARS

SPUR GEARS

RACKS

HELICAL GEARS AND  
SCREW GEARS

**MITER GEARS**

BEVEL GEARS

WORMS AND WORM  
WHEELS

REFERENCES

# M

## Straight Miter (White POM)

Module 1

Gear Ratio 1 : 1

Allowable transfer capability for different revolutions per minute Bending strength (Unit: W)							Backlash (Unit: mm)	Catalogue number
10 rpm	100 rpm	200 rpm	400 rpm	600 rpm	800 rpm	1,000 rpm		
0.34	3.50	7.00	14.00	21.00	27.98	33.82	0.05 to 0.12	<b>M1D 25 * 2306</b>
0.52	5.24	10.48	20.94	31.44	40.54	48.38	0.05 to 0.12	<b>M1D 30 – 2608</b>
0.52	5.24	10.48	20.94	31.44	40.54	48.38	0.05 to 0.12	<b>M1D 30 * 2608</b>



Unit: mm

Accuracy Class	Material	Pressure angle	Heat treatment	Tooth surface hardness	Backlash ①
—	Blue POM	20°	—	—	See the table below.

★ This is a machined product.

★ This allowable transfer capability table was prepared by using the Lewis formula. For the unit conversion method, refer to P. 20 in "References."

★ Because of the material characteristics, the dimensions and accuracy change with time and due to temperature changes.

★ The values in parentheses below "Tip diameter  $d_a$ " are theoretical values. The actual maximum diameter is the value obtained after the teeth are chamfered parallel to the shaft center. (See Fig. 1.)

★ For details on blue POM, refer to P. 22.

① This is a theoretical value obtained when a pair of gears of the same type and material are meshed with each other.

Catalogue number	Gear ratio	Number of teeth	Reference diameter	Tip diameter	Assembly distance	Hole diameter	Hub diameter	Hub length	Hole length	Overall length	Distance from end face to tip	Face width	Tip angle	Counterbore diameter (Reference value)	Weight
	$u$	$z$	$d$	$d_a$	$A$	$d_h$	$d_h$	$l_h$	$l$	$l_w$	$l_a$	$b$	$\delta_a$	$d_s$	$W(g)$
<b>M80BP 20 — 1604</b>	1 : 1	20	$\phi 16$	$\phi 17.13$	16	$\phi 4$	$\phi 12$	6	10	11	8.57	3.7	49° 3'	$\phi 9.53$	1.7
<b>M80BP 25 — 1805</b>		25	$\phi 20$	$\phi 21.13$	18	$\phi 5$	$\phi 16$	6	10.5	11.67	8.57	4.7	48° 51'	$\phi 11.70$	3.0
<b>M80BP 30 — 2005</b>		30	$\phi 24$	$\phi 25.13$	20	$\phi 5$	$\phi 18$	6	11	12.34	8.57	5.6	47° 42'	$\phi 14.16$	4.5
<b>M1BP 20 — 2105</b>		20	$\phi 20$	$\phi 21.41$	21	$\phi 5$	$\phi 16$	9	13	14.53	11.71	4.3	49° 3'	$\phi 11.83$	3.7
<b>M1BP 25 — 2306</b>		25	$\phi 25$	$\phi 26.41$	23	$\phi 6$	$\phi 20$	8	13	14.7	11.21	5.3	48° 51'	$\phi 15.01$	6.0
<b>M1BP 30 — 2606</b>		30	$\phi 30$	$\phi 31.41$	26	$\phi 6$	$\phi 22$	8.9	14.5	15.89	11.71	6.2	47° 42'	$\phi 19.46$	8.8
<b>M1.25BP 20 — 2406</b>		20	$\phi 25$	$\phi 26.77$	24	$\phi 6$	$\phi 20$	8.99	14	16	12.38	5.5	49° 3'	$\phi 14.43$	6.4
<b>M1.25BP 25 — 2808</b>		25	$\phi 31.25$	$\phi 33.02$	28	$\phi 8$	$\phi 26$	9.75	15.5	17.35	13.26	6.2	48° 51'	$\phi 19.96$	11.5
<b>M1.25BP 30 — 3208</b>		30	$\phi 37.5$	$\phi 39.27$	32	$\phi 8$	$\phi 28$	10	17	18.85	14.13	7	47° 42'	$\phi 25.20$	16.6
<b>M1.5BP 20 — 2808</b>		20	$\phi 30$	$\phi 32.12$	28	$\phi 8$	$\phi 24$	10	16.5	18.53	14.06	6.8	49° 3'	$\phi 17.75$	10.5
<b>M1.5BP 25 — 3410</b>		25	$\phi 37.5$	$\phi 39.62$	34	$\phi 10$	$\phi 30$	11.5	19	21.26	16.31	7.5	48° 51'	$\phi 23.8$	19.9
<b>M1.5BP 30 — 3810</b>		30	$\phi 45$	$\phi 47.12$	38	$\phi 10$	$\phi 33$	12.34	21	22.83	16.56	9.3	47° 42'	$\phi 29.69$	28.4
<b>M2BP 20 — 3710</b>		20	$\phi 40$	$\phi 41.32$ <sup>(<math>\phi 42.83</math>)</sup>	37	$\phi 10$	$\phi 34$	14	21	24	18.41	8.5	49° 3'	$\phi 23.94$	26.4
<b>M2BP 25 — 4012</b>		25	$\phi 50$	$\phi 51.33$ <sup>(<math>\phi 52.83</math>)</sup>	40	$\phi 12$	$\phi 42$	10.99	21	23.34	16.41	10.5	48° 51'	$\phi 32.30$	41.7
<b>M2BP 30 — 5112</b>		30	$\phi 60$	$\phi 61.36$ <sup>(<math>\phi 62.83</math>)</sup>	51	$\phi 12$	$\phi 44$	16.79	28	30.77	22.41	12.4	47° 42'	$\phi 38.92$	68.4
<b>M2.5BP 20 — 4812</b>		20	$\phi 50$	$\phi 51.66$ <sup>(<math>\phi 53.54</math>)</sup>	48	$\phi 12$	$\phi 42$	19	28	32.06	24.77	11.1	49° 3'	$\phi 28.58$	54.4
<b>M2.5BP 25 — 5014</b>		25	$\phi 62.5$	$\phi 64.16$ <sup>(<math>\phi 66.04</math>)</sup>	50	$\phi 14$	$\phi 52$	13.5	27	29.42	20.52	13.5	48° 51'	$\phi 40.82$	81.0
<b>M2.5BP 30 — 6316</b>		30	$\phi 75$	$\phi 76.7$ <sup>(<math>\phi 78.54</math>)</sup>	63	$\phi 16$	$\phi 55$	20.5	34.5	37.71	27.27	15.5	47° 42'	$\phi 49.15$	130.5
<b>M3BP 20 — 5814</b>		20	$\phi 60$	$\phi 61.99$ <sup>(<math>\phi 64.24</math>)</sup>	58	$\phi 14$	$\phi 50$	23	35	39.06	30.12	13.6	49° 3'	$\phi 35.51$	95.9
<b>M3BP 25 — 6016</b>		25	$\phi 75$	$\phi 77$ <sup>(<math>\phi 79.24</math>)</sup>	60	$\phi 16$	$\phi 65$	17.5	32	35.31	24.62	16.2	48° 51'	$\phi 48.18$	146.2
<b>M3BP 30 — 7518</b>	30	$\phi 90$	$\phi 92.04$ <sup>(<math>\phi 94.24</math>)</sup>	75	$\phi 18$	$\phi 66$	23.64	40	44.65	32.12	18.6	47° 42'	$\phi 57.37$	222.9	

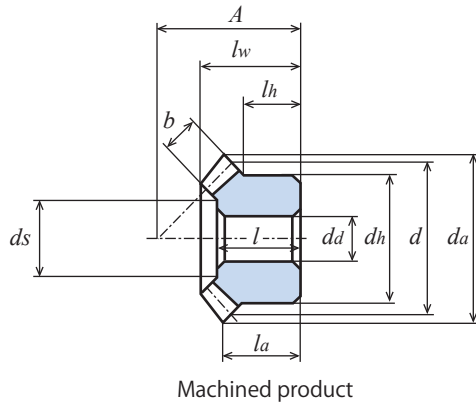

Machined product

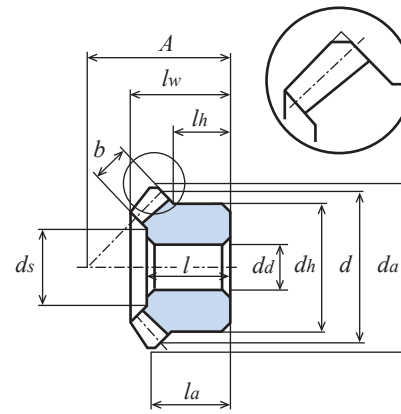

Fig. 1 (Tip chamfering)

Allowable transfer capability for different revolutions per minute Bending strength (Unit: W)							Backlash (Unit: mm)	Catalogue number
10 rpm	100 rpm	200 rpm	400 rpm	600 rpm	800 rpm	1,000 rpm		
0.12	1.20	2.42	4.84	7.26	9.68	12.12	0.02 to 0.08	<b>M80BP 20 – 1604</b>
0.20	2.06	4.12	8.26	12.38	16.52	20.66	0.02 to 0.08	<b>M80BP 25 – 1805</b>
0.30	3.12	6.24	12.50	18.76	24.98	31.24	0.02 to 0.08	<b>M80BP 30 – 2005</b>
0.20	2.10	4.24	8.46	12.70	16.94	20.94	0.05 to 0.12	<b>M1BP 20 – 2105</b>
0.34	3.50	7.00	14.00	21.00	27.98	33.82	0.05 to 0.12	<b>M1BP 25 – 2306</b>
0.52	5.24	10.48	20.94	31.44	40.54	48.38	0.05 to 0.12	<b>M1BP 30 – 2606</b>
0.40	4.18	8.38	16.78	25.18	33.42	41.34	0.05 to 0.12	<b>M1.25BP 20 – 2406</b>
0.64	6.50	13.00	26.04	39.00	49.92	59.64	0.05 to 0.12	<b>M1.25BP 25 – 2808</b>
0.92	9.38	18.78	37.54	54.86	69.56	82.86	0.05 to 0.12	<b>M1.25BP 30 – 3208</b>
0.68	6.86	13.76	27.55	41.31	53.21	63.77	0.05 to 0.12	<b>M1.5BP 20 – 2808</b>
1.04	10.45	20.92	41.87	61.33	77.57	92.33	0.05 to 0.12	<b>M1.5BP 25 – 3410</b>
1.63	16.34	32.69	65.40	92.83	116.55	137.77	0.05 to 0.12	<b>M1.5BP 30 – 3810</b>
1.48	15.36	30.90	61.79	89.54	113.04	134.31	0.05 to 0.12	<b>M2BP 20 – 3710</b>
2.41	25.72	51.62	102.49	143.75	179.64	211.46	0.05 to 0.12	<b>M2BP 25 – 4012</b>
3.70	38.67	77.33	149.67	207.39	256.78	302.85	0.05 to 0.12	<b>M2BP 30 – 5112</b>
2.96	31.27	62.53	124.32	174.09	217.75	256.23	0.06 to 0.15	<b>M2.5BP 20 – 4812</b>
5.00	51.62	103.23	197.77	273.80	338.37	401.64	0.06 to 0.15	<b>M2.5BP 25 – 5014</b>
7.40	75.48	151.15	280.65	382.95	473.05	575.17	0.06 to 0.15	<b>M2.5BP 30 – 6316</b>
5.37	54.95	109.89	212.38	294.34	364.64	429.76	0.06 to 0.15	<b>M3BP 20 – 5814</b>
8.88	89.17	178.34	330.97	451.77	557.96	678.40	0.06 to 0.15	<b>M3BP 25 – 6016</b>
12.95	130.61	261.41	466.57	627.89	799.57	967.92	0.06 to 0.15	<b>M3BP 30 – 7518</b>

CONTENTS

INFORMATION

GEARBOXES

ANTI-BACKLASH  
SPUR GEARS

SPUR GEARS

RACKS

HELICAL GEARS AND  
SCREW GEARS

**MITER GEARS**

BEVEL GEARS

WORMS AND WORM  
WHEELS

REFERENCES

# Ground bevel gears

## Bevel gears

BG series  
B series



\* These are samples

### How to Read Catalogue Numbers

**BG 1.5 S 20 L 30 R – 12 H**

Gear type	Module	Material	Number of teeth	Tooth trace shape	Number of teeth of mating gear	Tooth trace shape of mating gear	Hole finish	Hole diameter	Type
BG: Ground spiral bevel gear	Represents the module size.	S: SCM440	Example: When the number of teeth is 20: "20"	R: Right-hand spiral L: Left-hand spiral	Example: When the number of teeth is 30: "30"	R: Right-hand spiral L: Left-hand spiral	Grinding finish	Unit: mm	Induction hardening of teeth

**B 1.5 S 45 R – 12 H**

Gear type	Module	Material	Number of teeth	Tooth trace shape	Hole finish	Hole diameter	Type
B: Bevel gear	Represents the module size. When the module is less than 1, the figure indicates a value 100 times the actual module size. Example: Module 0.5 → "50" Module 0.8 → "80"	S : S45C SU: Stainless steel SUS304 B : Brass C3604B	Example: When the number of teeth is 45: "45"	Blank: Straight R: Right-hand spiral L: Left-hand spiral	Lathe turning finish [-]: No screw holes provided, no key grooves provided [+]: One screw hole provided [*]: Two screw holes provided [=]: Key groove provided [#]: One key groove and one screw hole provided	Unit: mm	Induction hardening of teeth

Catalogue number	BG	B	B	B	B	B
Shape						
Page	P. 244	P. 246	P. 248	P. 250	P. 252	P. 254
Material	SCM440	S45C	S45C	S45C	S45C	SUS304
Module	m1.5 to 2.5	m1 to 3	m1 to 2.5	m0.5 to 3	m1.5 to 4	m0.8 to 2
Tooth trace shape	<b>Spiral</b>	<b>Spiral</b>	<b>Spiral</b>	Straight	Straight	Straight
Accuracy grade	JIS Class 1	JIS Class 3	JIS Class 4	JIS Class 3	JIS Class 4	JIS Class 4
Teeth process sequence	Grinding after Induction hardening	Cutting	Induction hardening after cutting	Cutting	Induction hardening after cutting	Cutting

Catalogue number	B
Shape	
Page	P. 254
Material	Brass
Module	m0.5 to 0.8
Tooth trace shape	Straight
Accuracy grade	JIS Class 4
Teeth process sequence	Cutting



# Bevel gear information

## 1. Features of Bevel Gears and Cautions on Selection

Since bevel gears have a gear ratio other than 1:1, they cannot be used as a miter gear (gear ratio = 1:1) even if the number of teeth and module are the same. In designing bevel gears, the pitch angle and shaft angle are determined according to the gear ratio. Since the gears and pinions of bevel gears are designed and manufactured as a pair, you must select an appropriate pair of bevel gears to be meshed.

Example: A gear designed to have a gear ratio (pinion shaft P : gear shaft G) of 1:2 cannot be meshed with a gear designed to have a gear ratio of 1:3. For details, see the table below:

	Miter gear	Bevel gear					
Gear ratio (P : G)	1 : 1	1 : 1.5		1 : 3			
Pitch angle	45°	Pinion	33° 41'	Pinion	26° 34'	Pinion	18° 26'
		Gear	56° 19'	Gear	63° 26'	Gear	71° 34'
Shaft angle	90°						

\* In designing and manufacturing bevel gears, the pitch angle and other parameters differ depending on the gear ratio.

## 2. Differences between Straight Bevel Gears and Spiral Bevel Gears

	Tooth trace	Tooth surface grinding	High-speed rotation	Circumferential velocity of pitch circle*	Contact ratio	Rotation smoothness	Thrust
Straight bevel gear	Linear	Not possible	○	Less than 5.5 m/s	Low	○	Small
Spiral bevel gear	Curved	Possible	◎	5.5 m/s or more <b>When the velocity is 15 m/s or more, use a ground product.</b>	High	◎	Large

\* Circumferential velocity [m/s] =  $\frac{\pi \times \text{Reference diameter [mm]} \times \text{Revolutions per minute [rpm]}}{1000 \times 60}$

- Spiral bevel gear:
- ① Low noise can be expected with a high contact ratio.
  - ② Right-hand and left-hand gears can be combined.

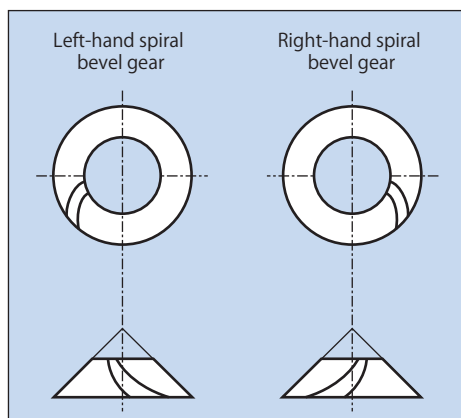

Left hand



Right hand

# Bevel gear information

## 3. Cautions on assembly

### 1) Installation

Particular attention is required when installing bevel gears. In general, bevel gears have a bearing only on one side and their shafts bend easily when subjected to a load, which is one of their main disadvantages. This results in poor, uneven tooth contact. Make sure that the gear shafts and bearings have adequate toughness and the bearings are located close to the gears. Assemble bevel gears so that they can be adjusted in the axial direction and insert a shim into the hub end face. This enables easy adjustment of the tooth contact.

### 2) Mating gear

This product cannot be used with other companies' products. If your device is designed with a product other than the standard products, use our customization service. Use a ground gear with a ground gear, and a cut gear with a cut gear.

### 3) Lubrication

Select an appropriate lubrication method according to the revolutions per minute and load conditions. For details, refer to "Lubrication of Gears" in "References."

### 4) Gear shafts and backlash

To achieve ideal intermeshing, assemble the gears at as accurate a shaft angle as possible with an appropriate backlash. For both ground gears and cut gears, the recommended shaft angle and shaft center height misalignment are  $\pm 15'$  and  $\pm 0.015$  mm or less, respectively.

Backlash: Our products are designed to have the backlash shown in Table 1 when the gears are assembled with the assembly distance given in the catalogue. For details, refer to "How to Measure Backlash" in "References."

Thrust acting on spiral bevel gear

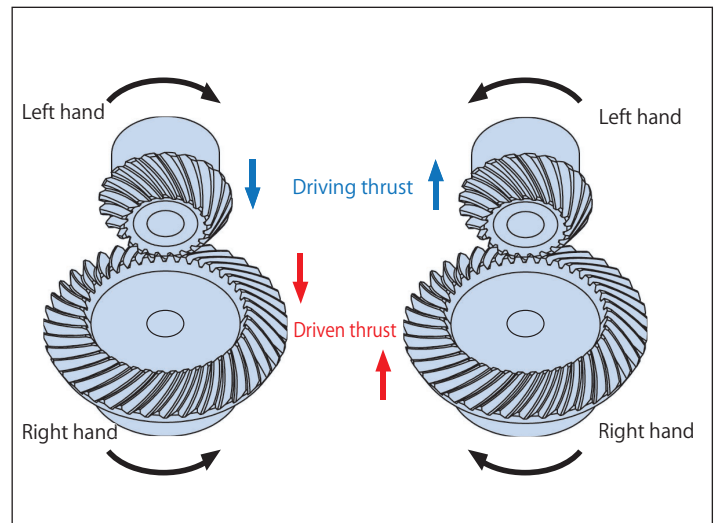

Table 1 Backlash of bevel gears (when a pair of gears are meshed, same for straight and spiral bevel gears)

Backlash of ground bevel gears

Module	Backlash [mm]
	SCM440
m = 1.5	0.03 to 0.06
m = 2	0.04 to 0.08
m = 2.5	0.05 to 0.1
m = 3	0.06 to 0.12

Backlash of cut bevel gears

Module	Backlash [mm]	
	SCM435·440, S45C, SUS304, C3604B	White/blue POM
m ≤ 0.9	0.02 to 0.08	0.03 to 0.10
More than 0.9 and 2 or less	0.05 to 0.12	0.05 to 0.16
More than 2 and 4 or less	0.06 to 0.15	-
More than 4 and 6 or less	0.08 to 0.20	-

- Adjustment: The assembly distance, backlash, and tooth contact can easily be adjusted by inserting a shim into the hub end face.
- Change in circumferential backlash (when a bevel gear is moved in the axial direction): Table 2

Table 2 Change in circumferential backlash of bevel gears

Gear ratio (P : G)	Straight bevel gear			Spiral bevel gear		
	1 : 1.5	1 : 2	1 : 3	1 : 1.5	1 : 2	1 : 3
Pinion $J_t = J_x \times$	0.40	0.33	0.23	0.49	0.40	0.28
Gear $J_t = J_x \times$	0.61	0.65	0.69	0.74	0.79	0.84

$J_t$ : Change in circumferential backlash

$J_x$ : Axial displacement

\* The backlash may not be as estimated depending on machining or assembly accuracy.

## 4. Features of Ground Spiral Bevel Gears (BG Series)

Accuracy grade	Hardening	Tooth surface finish	Ground areas	Module	Gear ratio	Backlash	High-speed rotation	Noise	Tooth surface hardness
JIS B 1704 Class 1	Induction hardening	Grinding	Hole diameter Hub lateral face Hub circumference Tooth tip circumference Tooth lateral face	$m = 1.5$ 2.0 2.5	$u = 1 : 1.5$ 1 : 2 1 : 3	Settable to up to $30 \mu\text{m}$	◎	Low	HRC52 to 60

\* Do not mesh a ground gear with a cut gear.

### Cautions on additional machining

- 1) The hub circumference and tooth tip circumference have been finished by grinding to ensure adequate accuracy and workability at the time of additional machining by customers.  
(The tooth tip circumference has been chamfered parallel to the shaft center, which enables accurate chucking.)  
For the cautions on additional machining, refer to Fig. 1 and "Precautions for additional processing" in the KG-General Catalogue.
- 2) Be sure to use a soft jaw and scroll chuck. Adjust the runout of the product to as close to zero as possible.  
(The runout should be 0.003 mm or less.)

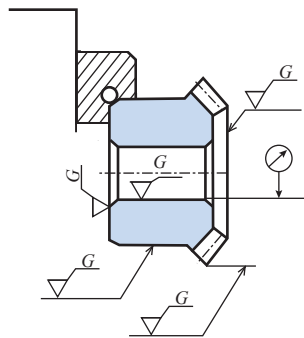

For high-accuracy additional machining, the hub circumference and end faces have been finished by grinding.

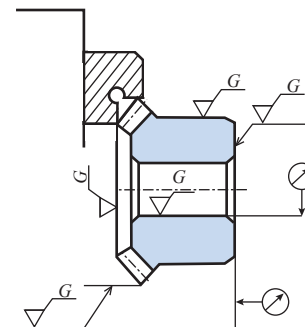

For high-accuracy additional machining, the tooth tip circumference and end faces have been finished by grinding.

Fig. 1 Additional machining

CONTENTS

INFORMATION

GEARBOXES

ANTI-BACKLASH  
SPUR GEARS

SPUR GEARS

RACKS

HELICAL GEARS AND  
SCREW GEARS

MITER GEARS

**BEVEL GEARS**

WORMS AND WORM  
WHEELS

REFERENCES



Unit: mm

Accuracy Class	Material	Pressure angle	Helix angle	Heat treatment	Tooth surface hardness	Backlash ①
[JIS B 1704] 1	SCM440	20°	35°	Induction hardening of teeth	HRC52 to 60	See the table below.

- ★ No surface treatment is applied. The allowable transfer capability table was prepared based on the assumption that the pinion (left-hand gear) is on the input side.
- ★ This allowable transfer capability table was prepared by using the formulas presented by the JGMA (Japan Gear Manufacturers Association). For the unit conversion method, refer to P. 20 in "References."
- ★ The values in parentheses below "Tip diameter  $da$ " are theoretical values. The actual maximum diameter is the value obtained after the teeth are chamfered parallel to the shaft center. (See Fig. 1.)

① This is a theoretical value obtained when a pair of gears of the same type and material are meshed with each other.

Catalogue number	Gear ratio	Number of teeth	Reference diameter	Tip diameter	Assembly distance	Hole diameter	Hub diameter	Hub length	Hole length	Overall length	Distance from end face to tip	Face width	Tip angle	Counterbore diameter (Reference value)	Weight
<b>BG1.5S 20L30R – 8H</b>	1 : 1.5	20	$\phi$ 30	$\phi$ 31.5 <sup>(<math>\phi</math>32.96)</sup>	37	$\phi$ 8	$\phi$ 26	13.16	20	22.49	15.48	9	39°08'	$\phi$ 14.07	79.0
<b>BG1.5S 30R20L – 8H</b>		30	$\phi$ 45	$\phi$ 44.6 <sup>(<math>\phi</math>46.02)</sup>	26	$\phi$ 8	$\phi$ 32	8	14	16.39	11.77	9	59°11'	$\phi$ 27.45	112.8
<b>BG1.5S 20L40R – 8H</b>	1 : 2	20	$\phi$ 30	$\phi$ 32 <sup>(<math>\phi</math>33.45)</sup>	45	$\phi$ 8	$\phi$ 26	14	24	25.29	15.87	11	31°21'	$\phi$ 16.80	90.5
<b>BG1.5S 40R20L – 10H</b>		40	$\phi$ 60	$\phi$ 59.5 <sup>(<math>\phi</math>60.69)</sup>	30	$\phi$ 10	$\phi$ 40	10	18	20.27	15.69	11	65°24'	$\phi$ 38.40	247.9
<b>BG1.5S 15L45R – 8H</b>	1 : 3	15	$\phi$ 22.5	$\phi$ 25.2 <sup>(<math>\phi</math>26.37)</sup>	45	$\phi$ 8	$\phi$ 20	10.83	21	22.03	11.89	11	23°19'	$\phi$ 11.45	42.3
<b>BG1.5S 45R15L – 12H</b>		45	$\phi$ 67.5	$\phi$ 67 <sup>(<math>\phi</math>67.92)</sup>	30	$\phi$ 12	$\phi$ 45	12	20	22.56	19.38	11	73°13'	$\phi$ 45.14	350.3
<b>BG2S 20L30R – 10H</b>	1 : 1.5	20	$\phi$ 40	$\phi$ 42.2 <sup>(<math>\phi</math>43.94)</sup>	45	$\phi$ 10	$\phi$ 34	12.99	22	24.87	16.31	11	39°12'	$\phi$ 21.36	153.4
<b>BG2S 30R20L – 12H</b>		30	$\phi$ 60	$\phi$ 60 <sup>(<math>\phi</math>61.35)</sup>	40	$\phi$ 12	$\phi$ 40	15	23	26.66	21.02	11	59°12'	$\phi$ 37.55	294.8
<b>BG2S 20L40R – 12H</b>	1 : 2	20	$\phi$ 40	$\phi$ 43.2 <sup>(<math>\phi</math>44.68)</sup>	60	$\phi$ 12	$\phi$ 35	18.75	32	34	21.17	15	31°36'	$\phi$ 20.91	175.8
<b>BG2S 40R20L – 12H</b>		40	$\phi$ 80	$\phi$ 79.5 <sup>(<math>\phi</math>80.93)</sup>	45	$\phi$ 12	$\phi$ 50	18	27	32.16	25.93	15	65°29'	$\phi$ 48.46	616.2
<b>BG2S 15L45R – 10H</b>	1 : 3	15	$\phi$ 30	$\phi$ 33.8 <sup>(<math>\phi</math>35.13)</sup>	60	$\phi$ 10	$\phi$ 24.5	14.08	29	29.69	15.85	15	23°07'	$\phi$ 19.16	94.4
<b>BG2S 45R15L – 12H</b>		45	$\phi$ 90	$\phi$ 89.5 <sup>(<math>\phi</math>90.55)</sup>	40	$\phi$ 12	$\phi$ 60	17	26	30.18	25.83	15	73°07'	$\phi$ 59.04	815.4
<b>BG2.5S 20L30R – 12H</b>	1 : 1.5	20	$\phi$ 50	$\phi$ 53.5 <sup>(<math>\phi</math>55)</sup>	55	$\phi$ 12	$\phi$ 44	15.49	28	30.81	19.16	15	39°24'	$\phi$ 27.44	311.0
<b>BG2.5S 30R20L – 15H</b>		30	$\phi$ 75	$\phi$ 75 <sup>(<math>\phi</math>76.72)</sup>	50	$\phi$ 15	$\phi$ 50	18	30	33.97	26.3	15	59°17'	$\phi$ 45.6	605.3
<b>BG2.5S 20L40R – 12H</b>	1 : 2	20	$\phi$ 50	$\phi$ 54.2 <sup>(<math>\phi</math>55.55)</sup>	75	$\phi$ 12	$\phi$ 44	23.5	40	43.66	26.39	20	30°31'	$\phi$ 20.54	441.2
<b>BG2.5S 40R20L – 15H</b>		40	$\phi$ 100	$\phi$ 100 <sup>(<math>\phi</math>101.1)</sup>	55	$\phi$ 15	$\phi$ 65	20	34	39.55	31.1	20	65°01'	$\phi$ 59.28	1294.1
<b>BG2.5S 15L45R – 12H</b>	1 : 3	15	$\phi$ 37.5	$\phi$ 42.5 <sup>(<math>\phi</math>43.55)</sup>	75	$\phi$ 12	$\phi$ 33	18	37	38.34	19.75	20	21°57'	$\phi$ 20.54	206.6
<b>BG2.5S 45R15L – 15H</b>		45	$\phi$ 112.5	$\phi$ 112.2 <sup>(<math>\phi</math>113.15)</sup>	50	$\phi$ 15	$\phi$ 75	22	35	38.16	32.22	20	72°43'	$\phi$ 72.84	1655.6



2D • 3D CAD

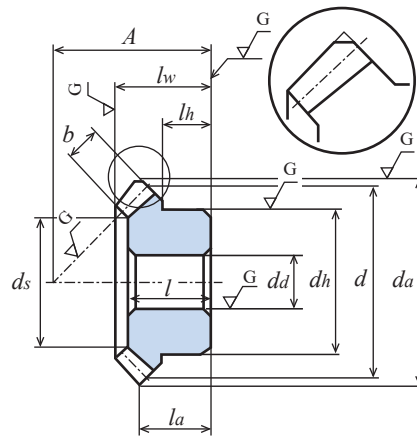

Fig. 1 (Tip chamfering)

Allowable transfer capability for different revolutions per minute Bending strength (Unit: kW)									Allowable transfer capability for different revolutions per minute Surface durability (Unit: kW)									Backlash (Unit: mm)	Catalogue number
250 rpm	500 rpm	800 rpm	1,000 rpm	1,500 rpm	2,000 rpm	2,500 rpm	3,000 rpm	4,000 rpm	250 rpm	500 rpm	800 rpm	1,000 rpm	1,500 rpm	2,000 rpm	2,500 rpm	3,000 rpm	4,000 rpm		
0.19	0.37	0.59	0.72	1.04	1.34	1.65	1.95	2.53	0.11	0.23	0.37	0.46	0.68	0.89	1.10	1.31	1.73	0.03 to 0.06	<b>BG1.5S 20L30R – 8H</b> -
-	-	-	-	-	-	-	-	-	-	-	-	-	-	-	-	-	-	0.03 to 0.06	<b>BG1.5S 20L40R – 8H</b> -
0.24	0.47	0.75	0.92	1.33	1.72	2.11	2.49	3.24	0.15	0.30	0.49	0.61	0.89	1.17	1.45	1.72	2.26	0.03 to 0.06	<b>BG1.5S 15L45R – 8H</b> -
-	-	-	-	-	-	-	-	-	-	-	-	-	-	-	-	-	-	0.03 to 0.06	<b>BG1.5S 15L45R – 8H</b> -
0.18	0.36	0.58	0.71	1.04	1.35	1.64	1.94	2.52	0.08	0.17	0.28	0.35	0.53	0.69	0.85	1.01	1.33	0.04 to 0.08	<b>BG2S 20L30R – 10H</b> -
-	-	-	-	-	-	-	-	-	-	-	-	-	-	-	-	-	-	0.04 to 0.08	<b>BG2S 20L40R – 12H</b> -
0.41	0.83	1.28	1.57	2.25	2.94	3.59	4.25	5.48	0.26	0.53	0.84	1.04	1.52	2.00	2.48	2.95	3.86	0.04 to 0.08	<b>BG2S 15L45R – 10H</b> -
-	-	-	-	-	-	-	-	-	-	-	-	-	-	-	-	-	-	0.04 to 0.08	<b>BG2.5S 20L30R – 12H</b> -
0.56	1.13	1.75	2.14	3.07	4.00	4.89	5.78	7.47	0.36	0.74	1.18	1.46	2.13	2.81	3.47	4.13	5.41	0.05 to 0.1	<b>BG2.5S 20L40R – 12H</b> -
-	-	-	-	-	-	-	-	-	-	-	-	-	-	-	-	-	-	0.05 to 0.1	<b>BG2.5S 15L45R – 12H</b> -
0.42	0.85	1.34	1.65	2.39	3.08	3.78	4.46	5.80	0.21	0.43	0.69	0.86	1.26	1.65	2.04	2.43	3.20	0.05 to 0.1	<b>BG2.5S 20L30R – 12H</b> -
-	-	-	-	-	-	-	-	-	-	-	-	-	-	-	-	-	-	0.05 to 0.1	<b>BG2.5S 20L40R – 12H</b> -
0.85	1.68	2.59	3.16	4.56	5.91	7.26	8.55	10.82	0.54	1.10	1.73	2.13	3.14	4.12	5.11	6.06	7.77	0.05 to 0.1	<b>BG2.5S 15L45R – 12H</b> -
-	-	-	-	-	-	-	-	-	-	-	-	-	-	-	-	-	-	0.05 to 0.1	-
1.14	2.24	3.45	4.21	6.08	7.89	9.68	11.40	14.43	0.75	1.52	2.39	2.94	4.32	5.68	7.04	8.36	10.71	0.05 to 0.1	-
-	-	-	-	-	-	-	-	-	-	-	-	-	-	-	-	-	-	0.05 to 0.1	-
0.85	1.71	2.66	3.26	4.67	6.08	7.44	8.80	11.41	0.43	0.89	1.41	1.74	2.54	3.35	4.14	4.93	6.48	0.05 to 0.1	-
-	-	-	-	-	-	-	-	-	-	-	-	-	-	-	-	-	-	0.05 to 0.1	-



Unit: mm

Accuracy Class	Material	Pressure angle	Helix angle	Heat treatment	Tooth surface hardness	Backlash ①
[JIS B 1704] 3	S45C	20°	35°	—	—	See the table below.

★ No surface treatment is applied. The allowable transfer capability table was prepared based on the assumption that the pinion (left-hand gear) is on the input side.  
 ★ This allowable transfer capability table was prepared by using the formulas presented by the JGMA (Japan Gear Manufacturers Association). For the unit conversion method, refer to P. 20 in "References."

★ The values in parentheses below "Tip diameter  $d_a$ " are theoretical values. The actual maximum diameter is the value obtained after the teeth are chamfered parallel to the shaft center. (See Fig. 1.)

① This is a theoretical value obtained when a pair of gears of the same type and material are meshed with each other.

Catalogue number	Gear ratio	Number of teeth	Reference diameter	Tip diameter	Assembly distance	Hole diameter	Hub diameter	Hub length	Hole length	Overall length	Distance from end face to tip	Face width	Tip angle	Counterbore diameter (Reference value)	Weight
	$u$	$z$	$d$	$d_a$	$A$	$d_a(H7)$	$d_h$	$l_h$	$l$	$l_w$	$l_a$	$b$	$\delta_a$	$d_s$	$W(g)$
<b>B1S 20L – 8</b>	1 : 2	20	$\phi$ 20	$\phi$ 21.87	29.6	$\phi$ 8	$\phi$ 16	8.6	14	15	10.07	5.7	30°13'	$\phi$ 12.1	18.8
<b>B1S 40R – 10</b>		40	$\phi$ 40	$\phi$ 40.41	21.8	$\phi$ 10	$\phi$ 25	8	13	14.57	12.21	5.7	65°36'	$\phi$ 28.4	66.9
<b>B1S 15L – 6</b>	1 : 3	15	$\phi$ 15	$\phi$ 17.07	31	$\phi$ 6	$\phi$ 13	8.17	14.4	15.07	8.85	6.7	21°53'	$\phi$ 8.0	12.1
<b>B1S 45R – 10</b>		45	$\phi$ 45	$\phi$ 45.25	20	$\phi$ 10	$\phi$ 25	8	12.9	14.8	12.88	6.7	73°21'	$\phi$ 31.1	80.6
<b>B1.5S 18L – 8</b>	1 : 2	18	$\phi$ 27	$\phi$ 30.09	40.74	$\phi$ 8	$\phi$ 22	12.49	21	22.96	14.51	9.8	30°44'	$\phi$ 12.2	59.6
<b>B1.5S 36R – 10</b>		36	$\phi$ 54	$\phi$ 54.76	26.75	$\phi$ 10	$\phi$ 30	9	15.5	18.01	14.01	9.8	65°57'	$\phi$ 34.3	143.0
<b>B1.5S 15L – 8</b>	1 : 3	15	$\phi$ 22.5	$\phi$ 25.99	46	$\phi$ 8	$\phi$ 19.5	11.75	21.1	22.19	12.83	10.1	22°28'	$\phi$ 11.7	41.9
<b>B1.5S 45R – 12</b>		45	$\phi$ 67.5	$\phi$ 68.01	30	$\phi$ 12	$\phi$ 37.5	12	19.4	22.31	19.51	10.1	73°56'	$\phi$ 46.6	283.0
<b>B2S 18L – 10</b>	1 : 2	18	$\phi$ 36	$\phi$ 38.35 <sup>(<math>\phi</math>40.20)</sup>	53.12	$\phi$ 10	$\phi$ 28	15.12	27	29.36	18.17	13	30°53'	$\phi$ 17.4	130.3
<b>B2S 36R – 12</b>		36	$\phi$ 72	$\phi$ 71.41 <sup>(<math>\phi</math>73.05)</sup>	35.21	$\phi$ 12	$\phi$ 36	12	21	23.54	18.26	13	66° 6'	$\phi$ 46.7	318.4
<b>B2S 15L – 10</b>	1 : 3	15	$\phi$ 30	$\phi$ 33.35 <sup>(<math>\phi</math>34.66)</sup>	62	$\phi$ 10	$\phi$ 26	16.33	28.9	30.2	17.78	13.4	22°19'	$\phi$ 16.6	104.0
<b>B2S 45R – 14</b>		45	$\phi$ 90	$\phi$ 89.16 <sup>(<math>\phi</math>90.68)</sup>	40	$\phi$ 14	$\phi$ 50	16	25.9	29.76	26.02	13.4	73°47'	$\phi$ 62.3	680.6
<b>B3S 18L – 15</b>	1 : 2	18	$\phi$ 54	$\phi$ 57.37 <sup>(<math>\phi</math>60.07)</sup>	75.27	$\phi$ 15	$\phi$ 41	18.02	37	40.12	22.79	20	30° 9'	$\phi$ 27.5	390
<b>B3S 36R – 16</b>		36	$\phi$ 108	$\phi$ 107.0 <sup>(<math>\phi</math>109.47)</sup>	52.32	$\phi$ 16	$\phi$ 60	18	31	35.13	26.79	20	65°22'	$\phi$ 68.9	1,130



2D • 3D CAD

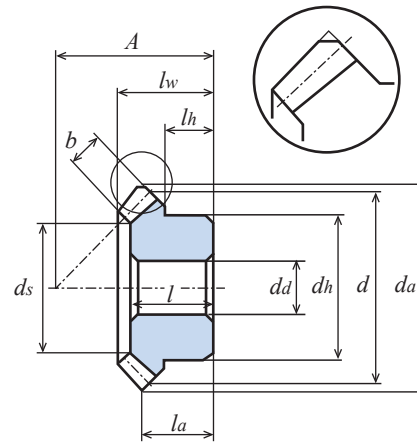
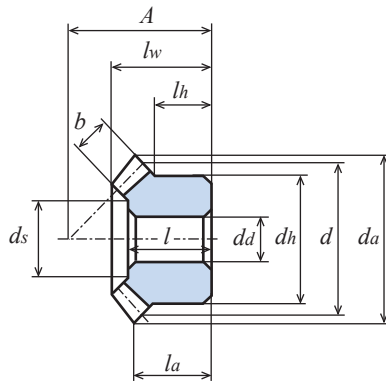

Fig. 1 (Tip chamfering)

Allowable transfer capability for different revolutions per minute Bending strength (Unit: W)							Allowable transfer capability for different revolutions per minute Surface durability (Unit: W)							Backlash (Unit: mm)	Catalogue number
300 rpm	600 rpm	900 rpm	1,200 rpm	1,500 rpm	1,800 rpm	2,000 rpm	300 rpm	600 rpm	900 rpm	1,200 rpm	1,500 rpm	1,800 rpm	2,000 rpm		
46.5	93.0	139.5	179.1	214.1	246.3	266.3	7.9	16.0	24.2	31.3	36.4	42.7	47.5	0.05 to 0.12	<b>B1S 20L – 8</b> <b>B1S 40R – 10</b>
35.7	71.5	107.3	143.1	174.2	202.1	219.7	5.0	10.1	15.2	20.4	25.0	29.2	31.8	0.05 to 0.12	<b>B1S 15L – 6</b> <b>B1S 45R – 10</b>
149.1	298.3	430.0	540.3	638.6	726.7	780.6	23.5	47.4	69.0	87.5	104.5	120.3	130.2	0.05 to 0.12	<b>B1.5S 18L – 8</b> <b>B1.5S 36R – 10</b>
126.2	252.5	375.3	475.5	566.1	648.5	699.4	17.8	36.0	53.9	68.9	82.6	95.5	103.6	0.05 to 0.12	<b>B1.5S 15L – 8</b> <b>B1.5S 45R – 12</b>
0.355 (kW)	0.697 (kW)	0.966 (kW)	1.196 (kW)	1.396 (kW)	1.617 (kW)	1.771 (kW)	0.057 (kW)	0.114 (kW)	0.160 (kW)	0.200 (kW)	0.238 (kW)	0.280 (kW)	0.309 (kW)	0.05 to 0.12	<b>B2S 18L – 10</b> <b>B2S 36R – 12</b>
0.304 (kW)	0.608 (kW)	0.859 (kW)	1.074 (kW)	1.264 (kW)	1.433 (kW)	1.552 (kW)	0.043 (kW)	0.088 (kW)	0.125 (kW)	0.159 (kW)	0.189 (kW)	0.217 (kW)	0.237 (kW)	0.05 to 0.12	<b>B2S 15L – 10</b> <b>B2S 45R – 14</b>
1.230 (kW)	2.228 (kW)	2.997 (kW)	3.729 (kW)	4.517 (kW)	5.262 (kW)	5.769 (kW)	0.206 (kW)	0.381 (kW)	0.524 (kW)	0.668 (kW)	0.808 (kW)	0.986 (kW)	1.098 (kW)	0.06 to 0.15	<b>B3S 18L – 15</b> <b>B3S 36R – 16</b>





Unit: mm

Accuracy Class	Material	Pressure angle	Helix angle	Heat treatment	Tooth surface hardness	Backlash ①
[JIS B 1704] 4	S45C	20°	35°	Induction hardening of teeth	HRC47 to 53	See the table below.

★ No surface treatment is applied. The allowable transfer capability table was prepared based on the assumption that the pinion (left-hand gear) is on the input side.  
 ★ This allowable transfer capability table was prepared by using the formulas presented by the JGMA (Japan Gear Manufacturers Association). For the unit conversion method, refer to P. 20 in "References."

★ Gears with a [\*] are provided with two screw holes and two set screws.

★ The values in parentheses below "Tip diameter  $d_a$ " are theoretical values. The actual maximum diameter is the value obtained after the teeth are chamfered parallel to the shaft center. (See Fig. 1.)

① This is a theoretical value obtained when a pair of gears of the same type and material are meshed with each other.

Catalogue number	Gear ratio	Number of teeth	Reference diameter	Tip diameter	Assembly distance	Hole diameter	Hub diameter	Hub length	Hole length	Overall length	Distance from end face to tip	Face width		Screw		Tip angle	Counterbore diameter (Reference value)	Weight
												$b$	$b_1$	2-M	$l_s$			
<b>B1S 20L * 8H</b>	1 : 2	20	$\phi$ 20	$\phi$ 21.87	29.6	$\phi$ 8	$\phi$ 16	8.6	14	15	10.07	5.7	2-M4	4	30°13'	$\phi$ 12.1	18.2	
<b>B1S 40R * 10H</b>		40	$\phi$ 40	$\phi$ 40.41	21.8	$\phi$ 10	$\phi$ 25	8	13	14.57	12.21	5.7	2-M5	4	65°36'	$\phi$ 28.4	65.1	
<b>B1S 15L * 6H</b>	1 : 3	15	$\phi$ 15	$\phi$ 17.07	31	$\phi$ 6	$\phi$ 13	8.17	14.4	15.07	8.85	6.7	2-M4	4	21°53'	$\phi$ 8.0	11.5	
<b>B1S 45R * 10H</b>		45	$\phi$ 45	$\phi$ 45.25	20	$\phi$ 10	$\phi$ 25	8	12.9	14.8	12.88	6.7	2-M5	4	73°21'	$\phi$ 31.1	78.8	
<b>B1.5S 18L – 8H</b>	1 : 2	18	$\phi$ 27	$\phi$ 30.09	40.74	$\phi$ 8	$\phi$ 22	12.49	21	22.96	14.51	9.8	-	-	30°44'	$\phi$ 12.2	59.6	
<b>B1.5S 36R – 10H</b>		36	$\phi$ 54	$\phi$ 54.76	26.75	$\phi$ 10	$\phi$ 30	9	15.5	18.01	14.01	9.8	-	-	65°57'	$\phi$ 34.3	143.0	
<b>B1.5S 15L – 8H</b>	1 : 3	15	$\phi$ 22.5	$\phi$ 25.99	46	$\phi$ 8	$\phi$ 19.5	11.75	21.1	22.19	12.83	10.1	-	-	22°28'	$\phi$ 11.7	41.9	
<b>B1.5S 45R – 12H</b>		45	$\phi$ 67.5	$\phi$ 68.01	30	$\phi$ 12	$\phi$ 37.5	12	19.4	22.31	19.51	10.1	-	-	73°56'	$\phi$ 46.6	283.0	
<b>B2S 18L – 10H</b>	1 : 2	18	$\phi$ 36	$\phi$ 38.35 <sup>(<math>\phi</math>40.20)</sup>	53.12	$\phi$ 10	$\phi$ 28	15.12	27	29.36	18.17	13	-	-	30°53'	$\phi$ 17.4	130.3	
<b>B2S 36R – 12H</b>		36	$\phi$ 72	$\phi$ 71.41 <sup>(<math>\phi</math>73.05)</sup>	35.21	$\phi$ 12	$\phi$ 36	12	21	23.54	18.26	13	-	-	66° 6'	$\phi$ 46.7	318.4	
<b>B2.5S 18L – 12H</b>	1 : 2	18	$\phi$ 45	$\phi$ 48.63 <sup>(<math>\phi</math>50.25)</sup>	64.29	$\phi$ 12	$\phi$ 36	17.04	32	34.98	20.6	16.7	-	-	30°53'	$\phi$ 21.2	250.0	
<b>B2.5S 36R – 14H</b>		36	$\phi$ 90	$\phi$ 89.88 <sup>(<math>\phi</math>91.32)</sup>	42.55	$\phi$ 14	$\phi$ 50	14	25	28.14	21.37	16.7	-	-	66° 6'	$\phi$ 57.6	640.0	



2D • 3D CAD

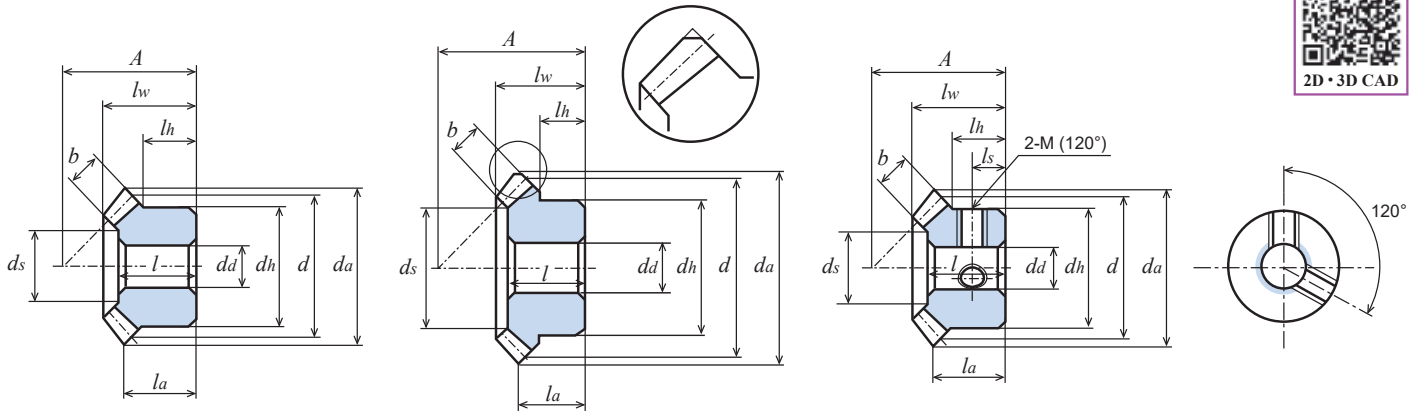

Fig. 1 (Tip chamfering)

Allowable transfer capability for different revolutions per minute Bending strength (Unit: W)							Allowable transfer capability for different revolutions per minute Surface durability (Unit: W)							Backlash (Unit: mm)	Catalogue number
300 rpm	600 rpm	900 rpm	1,200 rpm	1,500 rpm	1,800 rpm	2,000 rpm	300 rpm	600 rpm	900 rpm	1,200 rpm	1,500 rpm	1,800 rpm	2,000 rpm		
40.6	81.2	121.8	157.3	189.4	219.3	238.0	21.8	44.9	68.6	89.8	109.2	127.4	139.0	0.05 to 0.12	<b>B1S 20L * 8H</b> <b>B1S 40R * 10H</b>
31.2	62.4	93.7	124.9	152.8	178.2	194.4	13.8	28.6	43.7	59.0	72.9	85.7	93.9	0.05 to 0.12	<b>B1S 15L * 6H</b> <b>B1S 45R * 10H</b>
130.2	260.4	377.8	479.2	571.2	654.9	706.8	63.9	131.8	194.6	232.5	300.9	347.8	377.1	0.05 to 0.12	<b>B1.5S 18L – 8H</b> <b>B1.5S 36R – 10H</b>
110.2	220.4	328.2	419.2	502.9	580.1	628.3	48.7	100.5	152.4	197.1	238.5	277.7	302.2	0.05 to 0.12	<b>B1.5S 15L – 8H</b> <b>B1.5S 45R – 12H</b>
0.310 (kW)	0.611 (kW)	0.857 (kW)	1.073 (kW)	1.264 (kW)	1.452 (kW)	1.575 (kW)	0.155 (kW)	0.314 (kW)	0.448 (kW)	0.569 (kW)	0.677 (kW)	0.784 (kW)	0.854 (kW)	0.05 to 0.12	<b>B2S 18L – 10H</b> <b>B2S 36R – 12H</b>
0.620 (kW)	1.179 (kW)	1.631 (kW)	2.019 (kW)	2.395 (kW)	2.749 (kW)	2.968 (kW)	0.314 (kW)	0.615 (kW)	0.867 (kW)	1.086 (kW)	1.301 (kW)	1.505 (kW)	1.633 (kW)	0.06 to 0.15	<b>B2.5S 18L – 12H</b> <b>B2.5S 36R – 14H</b>



Unit: mm

Accuracy Class	Material	Pressure angle	Heat treatment	Tooth surface hardness	Backlash ①
[JIS B 1704] 3	S45C	20°	—	—	See the table below.

★ No surface treatment is applied. The allowable transfer capability table was prepared based on the assumption that the pinion is on the input side.

★ This allowable transfer capability table was prepared by using the formulas presented by the JGMA (Japan Gear Manufacturers Association). For the unit conversion method, refer to P. 20 in "References."

★ The values in parentheses below "Tip diameter  $d_a$ " are theoretical values. The actual maximum diameter is the value obtained after the teeth are chamfered parallel to the shaft center. (See Fig. 1.)

★ Gears with a [\*] are provided with two screw holes and two set screws.

① This is a theoretical value obtained when a pair of gears of the same type and material are meshed with each other.

Catalogue number	Gear ratio	Num-ber of teeth	Refer-ence diam-eter	Tip diam-eter	As-sem-bley dis-tance	Hole diam-eter	Hub diam-eter	Hub length	Hole length	Overall length	Dis-tance from end face to tip	Face width	Screw		Tip angle	Coun-terbore diam-eter (Refer-ence value)	Weight
													2-M	ls			
<b>B50S 20</b>	1 : 2	20	$\phi 10$	$\phi 10.89$	15.52	$\phi 3$ (H8)	$\phi 8$	5	8	8.54	5.74	3.2	-	-	29° 8'	$\phi 5.6$	3.0
<b>B50S 20 * 3</b>		20	$\phi 10$	$\phi 10.89$	15.52	$\phi 3$ (H8)	$\phi 8$	5	8	8.54	5.74	3.2	2-M2.5	2.5	29° 8'	$\phi 5.6$	2.8
<b>B50S 40</b>		40	$\phi 20$	$\phi 20.45$	10.56	$\phi 4$ (H8)	$\phi 12$	4	6.3	7.31	6.01	3.2	-	-	66° 0'	$\phi 13.5$	8.2
<b>B50S 40 * 4</b>		40	$\phi 20$	$\phi 20.45$	10.56	$\phi 4$ (H8)	$\phi 12$	4	6.3	7.31	6.01	3.2	2-M3	2	66° 0'	$\phi 13.5$	7.8
<b>B80S 20</b>	1 : 2	20	$\phi 16$	$\phi 17.43$	22.5	$\phi 5$	$\phi 12$	5.5	10	10.79	6.86	4.5	-	-	29° 8'	$\phi 9.8$	9.0
<b>B80S 40</b>		40	$\phi 32$	$\phi 32.72$	16.46	$\phi 6$	$\phi 20$	6	9.5	11.01	9.18	4.5	-	-	66° 0'	$\phi 22.9$	33.4
<b>B1S 20 - 6</b>	1 : 2	20	$\phi 20$	$\phi 21.79$	29.6	$\phi 6$	$\phi 16$	8.6	14	15.03	10.05	5.7	-	-	29° 8'	$\phi 12.1$	21.3
<b>B1S 20 * 6</b>		20	$\phi 20$	$\phi 21.79$	29.6	$\phi 6$	$\phi 16$	8.6	14	15.03	10.05	5.7	2-M4	4	29° 8'	$\phi 12.1$	20.5
<b>B1S 20 * 8</b>		20	$\phi 20$	$\phi 21.79$	29.6	$\phi 8$	$\phi 16$	8.6	14	15.03	10.05	5.7	2-M4	4	29° 8'	$\phi 12.1$	18.3
<b>B1S 40 - 8</b>		40	$\phi 40$	$\phi 40.89$	21.8	$\phi 8$	$\phi 25$	8	13	15.02	12.69	5.7	-	-	66° 0'	$\phi 28.4$	71.7
<b>B1S 40 * 8</b>		40	$\phi 40$	$\phi 40.89$	21.8	$\phi 8$	$\phi 25$	8	13	15.02	12.69	5.7	2-M5	4	66° 0'	$\phi 28.4$	69.6
<b>B1S 40 * 10</b>		40	$\phi 40$	$\phi 40.89$	21.8	$\phi 10$	$\phi 25$	8	13	15.02	12.69	5.7	2-M5	4	66° 0'	$\phi 28.4$	67.0
<b>B1S 15 - 6</b>	1 : 3	15	$\phi 15$	$\phi 17.67$	31	$\phi 6$	$\phi 13$	8.17	14.4	15.16	8.95	6.7	-	-	22° 17'	$\phi 8.0$	12.0
<b>B1S 15 * 6</b>		15	$\phi 15$	$\phi 17.67$	31	$\phi 6$	$\phi 13$	8.17	14.4	15.16	8.95	6.7	2-M4	4	22° 17'	$\phi 8.0$	11.4
<b>B1S 45 - 10</b>		45	$\phi 45$	$\phi 45.37$	20	$\phi 10$	$\phi 25$	8	12.9	14.97	13.06	6.7	-	-	73° 27'	$\phi 31.1$	86.0
<b>B1S 45 * 10</b>		45	$\phi 45$	$\phi 45.37$	20	$\phi 10$	$\phi 25$	8	12.9	14.97	13.06	6.7	2-M5	4	73° 27'	$\phi 31.1$	84.2
<b>B1.5S 18 - 8</b>	1 : 2	18	$\phi 27$	$\phi 29.68$	40.74	$\phi 8$	$\phi 22$	12.5	21	22.96	14.41	9.8	-	-	29° 25'	$\phi 12.2$	59.4
<b>B1.5S 36 - 10</b>		36	$\phi 54$	$\phi 55.34$	26.75	$\phi 10$	$\phi 30$	10	15.5	18.54	14.59	9.8	-	-	66° 17'	$\phi 34.3$	139.9
<b>B1.5S 15 - 8</b>	1 : 3	15	$\phi 22.5$	$\phi 26.51$	46	$\phi 8$	$\phi 19.5$	11.78	21.1	22.29	12.92	10.1	-	-	22° 17'	$\phi 11.7$	41.8
<b>B1.5S 45 - 12</b>		45	$\phi 67.5$	$\phi 68.06$	30	$\phi 12$	$\phi 37.5$	12	19.4	22.47	19.59	10.1	-	-	73° 27'	$\phi 46.6$	300.8
<b>B2S 18 - 10</b>	1 : 2	18	$\phi 36$	$\phi 37.81$ <sup>(<math>\phi 39.58</math>)</sup>	53.12	$\phi 10$	$\phi 28$	15.12	27	29	18.01	12.6	-	-	29° 25'	$\phi 19.1$	129.6
<b>B2S 36 - 12</b>		36	$\phi 72$	$\phi 72.15$ <sup>(<math>\phi 73.79</math>)</sup>	35.21	$\phi 12$	$\phi 36$	13	21	24.07	19	12.6	-	-	66° 17'	$\phi 47.6$	313.0
<b>B2S 15 - 10</b>	1 : 3	15	$\phi 30$	$\phi 34.19$ <sup>(<math>\phi 35.35</math>)</sup>	62	$\phi 10$	$\phi 26$	16.33	28.9	30.32	17.89	13.4	-	-	22° 17'	$\phi 16.6$	103.8
<b>B2S 45 - 14</b>		45	$\phi 90$	$\phi 89.29$ <sup>(<math>\phi 90.75</math>)</sup>	40	$\phi 14$	$\phi 50$	16	25.9	29.94	26.12	13.4	-	-	73° 27'	$\phi 62.3$	722.7
<b>B2.5S 18 - 12</b>	1 : 2	18	$\phi 45$	$\phi 47.27$ <sup>(<math>\phi 49.47</math>)</sup>	64.29	$\phi 12$	$\phi 36$	17	32	34.97	20.41	16.7	-	-	29° 25'	$\phi 21.1$	250
<b>B2.5S 36 - 14</b>		36	$\phi 90$	$\phi 90.18$ <sup>(<math>\phi 92.24</math>)</sup>	42.55	$\phi 14$	$\phi 50$	15	25	29.01	22.29	16.7	-	-	66° 17'	$\phi 57.5$	640
<b>B2.5S 15 - 10</b>	1 : 3	15	$\phi 37.5$	$\phi 42.74$ <sup>(<math>\phi 44.18</math>)</sup>	77.93	$\phi 10$ (H8)	$\phi 32$	20.8	38.5	40.41	22.79	19	-	-	22° 17'	$\phi 18.2$	220
<b>B2.5S 45 - 16</b>		45	$\phi 112.5$	$\phi 111.6$ <sup>(<math>\phi 113.44</math>)</sup>	40.67	$\phi 16$	$\phi 60$	14	24.5	28.74	23.32	19	-	-	73° 27'	$\phi 74.1$	1,100
<b>B3S 18 - 15</b>	1 : 2	18	$\phi 54$	$\phi 56.72$ <sup>(<math>\phi 59.37</math>)</sup>	75.27	$\phi 15$	$\phi 41$	18	37	40.06	22.61	20	-	-	29° 25'	$\phi 27.4$	390
<b>B3S 36 - 16</b>		36	$\phi 108$	$\phi 108.2$ <sup>(<math>\phi 110.68</math>)</sup>	52.32	$\phi 16$	$\phi 60$	19	31	36.06	28	20	-	-	66° 17'	$\phi 68.9$	1,150

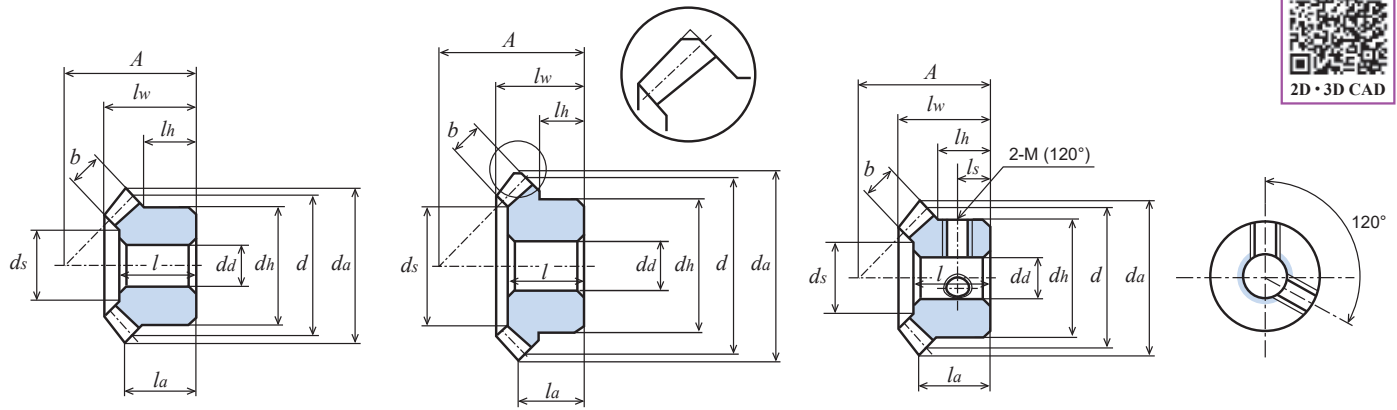

Fig. 1 (Tip chamfering)

Allowable transfer capability for different revolutions per minute Bending strength (Unit: W)							Allowable transfer capability for different revolutions per minute Surface durability (Unit: W)							Backlash (Unit: mm)	Catalogue number
10 rpm	100 rpm	200 rpm	400 rpm	600 rpm	800 rpm	1,000 rpm	10 rpm	100 rpm	200 rpm	400 rpm	600 rpm	800 rpm	1,000 rpm		
0.2	2.0	4.1	8.2	12.4	16.5	20.7	-	-	-	-	-	-	-	0.02 to 0.08	B50S 20 B50S 20 * 3 B50S 40 B50S 40 * 4
0.7	7.7	15.5	31.0	46.5	62.0	77.6	-	-	-	-	-	-	-	0.02 to 0.08	B80S 20 B80S 40
1.3	13.8	27.7	55.5	83.3	111.1	138.0	-	-	-	-	-	-	-	0.05 to 0.12	B1S 20 – 6 B1S 20 * 6 B1S 20 * 8 B1S 40 – 8 B1S 40 * 8 B1S 40 * 10
1.1	11.3	22.6	45.6	68.5	91.2	113.4	-	-	-	-	-	-	-	0.05 to 0.12	B1S 15 – 6 B1S 15 * 6 B1S 45 – 10 B1S 45 * 10
4.4	44.4	88.8	170.3	255.4	334.6	403.0	0.3	3.9	7.6	15.8	23.9	31.4	38.1	0.05 to 0.12	B1.5S 18 – 8 B1.5S 36 – 10
3.8	38.4	76.9	153.9	230.9	307.8	375.9	0.3	3.2	6.4	13.0	19.6	26.3	32.2	0.05 to 0.12	B1.5S 15 – 8 B1.5S 45 – 12
0.010 (kW)	0.102 (kW)	0.204 (kW)	0.408 (kW)	0.602 (kW)	0.764 (kW)	0.912 (kW)	-	0.010 (kW)	0.020 (kW)	0.040 (kW)	0.060 (kW)	0.077 (kW)	0.093 (kW)	0.05 to 0.12	B2S 18 – 10 B2S 36 – 12
0.009 (kW)	0.091 (kW)	0.182 (kW)	0.364 (kW)	0.546 (kW)	0.703 (kW)	0.844 (kW)	-	0.007 (kW)	0.015 (kW)	0.031 (kW)	0.047 (kW)	0.062 (kW)	0.075 (kW)	0.05 to 0.12	B2S 15 – 10 B2S 45 – 14
0.020 (kW)	0.209 (kW)	0.418 (kW)	0.837 (kW)	1.189 (kW)	1.494 (kW)	1.767 (kW)	0.002 (kW)	0.021 (kW)	0.042 (kW)	0.085 (kW)	0.122 (kW)	0.155 (kW)	0.186 (kW)	0.06 to 0.15	B2.5S 18 – 12 B2.5S 36 – 14
0.019 (kW)	0.197 (kW)	0.394 (kW)	0.789 (kW)	1.155 (kW)	1.464 (kW)	1.744 (kW)	0.001 (kW)	0.017 (kW)	0.034 (kW)	0.070 (kW)	0.104 (kW)	0.133 (kW)	0.160 (kW)	0.06 to 0.15	B2.5S 15 – 10 B2.5S 45 – 16
0.036 (kW)	0.361 (kW)	0.722 (kW)	1.419 (kW)	1.979 (kW)	2.465 (kW)	2.892 (kW)	0.003 (kW)	0.037 (kW)	0.074 (kW)	0.148 (kW)	0.209 (kW)	0.264 (kW)	0.315 (kW)	0.06 to 0.15	B3S 18 – 15 B3S 36 – 16



Unit: mm

Accuracy Class	Material	Pressure angle	Heat treatment	Tooth surface hardness	Backlash ①
[JIS B 1704] 4	S45C	20°	Induction hardening of teeth	HRC47 to 53	See the table below.

★ No surface treatment is applied. The allowable transfer capability table was prepared based on the assumption that the pinion is on the input side.

★ This allowable transfer capability table was prepared by using the formulas presented by the JGMA (Japan Gear Manufacturers Association). For the unit conversion method, refer to P. 20 in "References."

★ The values in parentheses below "Tip diameter  $d_a$ " are theoretical values. The actual maximum diameter is the value obtained after the teeth are chamfered parallel to the shaft center. (See Fig. 1.)

★ Gears with a [#] are provided with key grooves, keys, screw holes, and set screws.

① This is a theoretical value obtained when a pair of gears of the same type and material are meshed with each other.

Catalogue number	Gear ratio	Number of teeth	Reference diameter	Tip diameter	Assembly distance	Hole diameter	Hub diameter	Hub length	Hole length	Overall length	Distance from end face to tip	Face width	Key groove	Screw		Tip angle	Counterbore diameter (Reference value)	Weight
														2-M	ls			
	$u$	$z$	$d$	$d_a$	$A$	$d_a(H8)$	$d_h$	$l_h$	$l$	$l_w$	$l_a$	$b$	$b_2 \times l_2$			$\delta_a$	$d_s$	$W(g)$
<b>B1.5S 18 – 8H</b>	1 : 2	18	φ 27	φ 29.68	40.74	φ 8	φ 22	12.5	21	22.96	14.41	9.8	-	-	-	29°25'	φ 12.2	59.4
<b>B1.5S 18 # 10H</b>		18	φ 27	φ 29.68	40.74	φ 10	φ 22	12.5	21	22.96	14.41	9.8	3 × 1.4	2-M4	6.5	29°25'	φ 12.2	54.5
<b>B1.5S 36 – 10H</b>		36	φ 54	φ 55.34	26.75	φ 10	φ 30	10	15.5	18.54	14.59	9.8	-	-	-	66°17'	φ 34.3	139.9
<b>B1.5S 36 # 10H</b>		36	φ 54	φ 55.34	26.75	φ 10	φ 30	10	15.5	18.54	14.59	9.8	3 × 1.4	2-M4	5	66°17'	φ 34.3	138.6
<b>B1.5S 15 – 8H</b>	1 : 3	15	φ 22.5	φ 26.51	46	φ 8	φ 19.5	11.78	21.1	22.29	12.92	10.1	-	-	-	22°17'	φ 11.7	41.8
<b>B1.5S 15 # 8H</b>		15	φ 22.5	φ 26.51	46	φ 8	φ 19.5	11.78	21.1	22.29	12.92	10.1	3 × 1.4	2-M4	6	22°17'	φ 11.7	40.6
<b>B1.5S 45 – 12H</b>		45	φ 67.5	φ 68.06	30	φ 12	φ 37.5	12	19.4	22.47	19.59	10.1	-	-	-	73°27'	φ 46.6	300.8
For all the weight values below, the unit is kg.																		
<b>B2S 18 – 10H</b>	1 : 2	18	φ 36	φ <sup>(φ39.58)</sup> 37.81	53.12	φ 10	φ 28	15.12	27	29	18.01	12.6	-	-	-	29°25'	φ 19.1	0.13
<b>B2S 18 # 12H</b>		18	φ 36	φ <sup>(φ39.58)</sup> 37.81	53.12	φ 12	φ 28	15.12	27	29	18.01	12.6	4 × 1.8	2-M5	8	29°25'	φ 19.1	0.12
<b>B2S 36 – 12H</b>		36	φ 72	φ <sup>(φ73.79)</sup> 72.15	35.21	φ 12	φ 36	13	21	24.07	19	12.6	-	-	-	66°17'	φ 47.6	0.31
<b>B2S 36 # 18H</b>		36	φ 72	φ <sup>(φ73.79)</sup> 72.15	35.21	φ 18	φ 36	13	21	24.07	19	12.6	6 × 2.8	2-M5	6.5	66°17'	φ 47.6	0.29
<b>B2S 15 – 10H</b>	1 : 3	15	φ 30	φ <sup>(φ35.35)</sup> 34.19	62	φ 10	φ 26	16.33	28.9	30.32	17.89	13.4	-	-	-	22°17'	φ 16.6	0.10
<b>B2S 15 # 12H</b>		15	φ 30	φ <sup>(φ35.35)</sup> 34.19	62	φ 12	φ 26	16.33	28.9	30.32	17.89	13.4	4 × 1.8	2-M5	8.5	22°17'	φ 16.6	0.093
<b>B2S 45 – 14H</b>		45	φ 90	φ <sup>(φ90.75)</sup> 89.29	40	φ 14	φ 50	16	25.9	29.94	26.12	13.4	-	-	-	73°27'	φ 62.3	0.72
<b>B2S 45 # 20H</b>		45	φ 90	φ <sup>(φ90.75)</sup> 89.29	40	φ 20	φ 50	16	25.9	29.94	26.12	13.4	6 × 2.8	2-M5	8	73°27'	φ 62.3	0.69
<b>B2.5S 18 – 12H</b>	1 : 2	18	φ 45	φ <sup>(φ49.47)</sup> 47.27	64.29	φ 12	φ 36	17	32	34.97	20.41	16.7	-	-	-	29°25'	φ 21.1	0.25
<b>B2.5S 36 – 14H</b>		36	φ 90	φ <sup>(φ92.24)</sup> 90.18	42.55	φ 14	φ 50	15	25	29.01	22.29	16.7	-	-	-	66°17'	φ 57.5	0.64
<b>B2.5S 15 – 10H</b>	1 : 3	15	φ 37.5	φ <sup>(φ44.18)</sup> 42.74	77.93	φ 10	φ 32	20.8	38.5	40.41	22.79	19	-	-	-	22°17'	φ 18.2	0.22
<b>B2.5S 45 – 16H</b>		45	φ 112.5	φ <sup>(φ113.44)</sup> 111.6	40.67	φ 16	φ 60	14	24.5	28.74	23.32	19	-	-	-	73°27'	φ 74.1	1.10
<b>B3S 18 – 15H</b>	1 : 2	18	φ 54	φ <sup>(φ59.37)</sup> 56.72	75.27	φ 15	φ 41	18	37	40.06	22.61	20	-	-	-	29°25'	φ 27.4	0.39
<b>B3S 18 # 20H</b>		18	φ 54	φ <sup>(φ59.37)</sup> 56.72	75.27	φ 20	φ 41	18	37	40.06	22.61	20	6 × 2.8	2-M6	9	29°25'	φ 27.4	0.35
<b>B3S 36 – 16H</b>		36	φ 108	φ <sup>(φ110.68)</sup> 108.2	52.32	φ 16	φ 60	19	31	36.06	28	20	-	-	-	66°17'	φ 68.9	1.15
<b>B3S 36 # 25H</b>		36	φ 108	φ <sup>(φ110.68)</sup> 108.2	52.32	φ 25	φ 60	19	31	36.06	28	20	8 × 3.3	2-M6	9.5	66°17'	φ 68.9	1.07
<b>B3S 15 – 12H</b>	1 : 3	15	φ 45	φ <sup>(φ53.02)</sup> 51.29	89.36	φ 12	φ 36	20.3	42	44.53	23.2	23	-	-	-	22°17'	φ 20.3	0.34
<b>B3S 45 – 18H</b>		45	φ 135	φ <sup>(φ136.12)</sup> 133.9	50.95	φ 18	φ 70	19	32	36.69	30.13	23	-	-	-	73°27'	φ 88.8	1.95
<b>B4S 18 – 20H</b>	1 : 2	18	φ 72	φ <sup>(φ79.16)</sup> 75.63	99.73	φ 20	φ 55	23.5	48	52.02	29.52	25.8	-	-	-	29°25'	φ 37.6	0.94
<b>B4S 36 – 22H</b>		36	φ 144	φ <sup>(φ147.58)</sup> 144.3	71.56	φ 22	φ 75	23	42	49.53	39.14	25.8	-	-	-	66°17'	φ 92.7	2.89
<b>B4S 15 # 20H</b>	1 : 3	15	φ 60	φ <sup>(φ70.69)</sup> 68.38	119.14	φ 20	φ 52	27.8	57	59.67	30.92	31	6 × 2.8	2-M8	14	22°17'	φ 31.1	0.78
<b>B4S 45 # 30H</b>		45	φ 180	φ <sup>(φ181.5)</sup> 178.6	65.47	φ 30	φ 80	22	40	46.55	37.71	31	8 × 3.3	2-M8	11	73°27'	φ 117.6	4.19

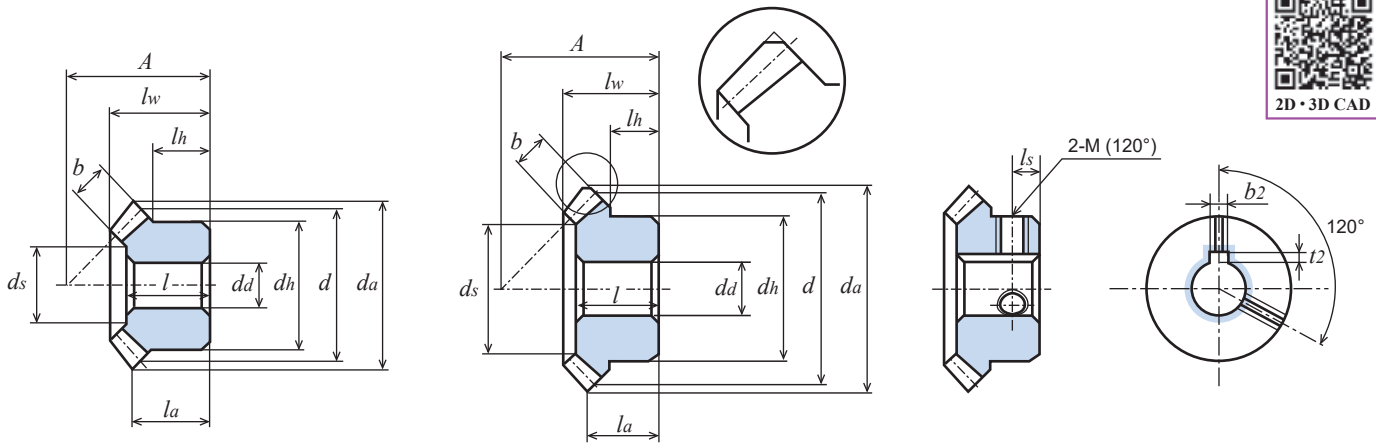

Fig. 1 (Tip chamfering)

Allowable transfer capability for different revolutions per minute Bending strength (Unit: W)							Allowable transfer capability for different revolutions per minute Surface durability (Unit: W)							Backlash (Unit: mm)	Catalogue number
10 rpm	100 rpm	200 rpm	400 rpm	600 rpm	800 rpm	1,000 rpm	10 rpm	100 rpm	200 rpm	400 rpm	600 rpm	800 rpm	1,000 rpm		
4.1	41.1	82.2	164.4	246.6	323.5	390.8	1.0	11.6	24.0	49.6	75.7	100.6	122.7	0.05 to 0.12	B1.5S 18 – 8H B1.5S 18 # 10H B1.5S 36 – 10H B1.5S 36 # 10H
3.6	36.5	73.0	146.1	219.2	292.3	357.5	0.8	9.1	18.8	38.9	59.4	80.2	99.0	0.05 to 0.12	B1.5S 15 – 8H B1.5S 15 # 8H B1.5S 45 – 12H
For all the values below, the unit is kW.															
0.009	0.095	0.190	0.380	0.562	0.716	0.857	0.002	0.027	0.057	0.118	0.177	0.228	0.276	0.05 to 0.12	B2S 18 – 10H B2S 18 # 12H B2S 36 – 12H B2S 36 # 18H
0.008	0.086	0.172	0.345	0.518	0.669	0.805	0.002	0.022	0.045	0.094	0.144	0.188	0.229	0.05 to 0.12	B2S 15 – 10H B2S 15 # 12H B2S 45 – 14H B2S 45 # 20H
0.019	0.192	0.385	0.771	1.100	1.389	1.649	0.005	0.057	0.118	0.243	0.353	0.452	0.542	0.06 to 0.15	B2.5S 18 – 12H B2.5S 36 – 14H
0.018	0.183	0.366	0.732	1.074	1.366	1.633	0.004	0.047	0.098	0.203	0.304	0.392	0.473	0.06 to 0.15	B2.5S 15 – 10H B2.5S 45 – 16H
0.033	0.332	0.665	1.310	1.837	2.300	2.710	0.009	0.100	0.207	0.420	0.600	0.761	0.905	0.06 to 0.15	B3S 18 – 15H B3S 18 # 20H B3S 36 – 16H B3S 36 # 25H
0.031	0.317	0.635	1.271	1.814	2.290	2.718	0.007	0.084	0.174	0.359	0.522	0.667	0.800	0.06 to 0.15	B3S 15 – 12H B3S 45 – 18H
0.077	0.773	1.546	2.908	4.007	4.943	5.883	0.021	0.239	0.494	0.958	1.344	1.679	2.018	0.06 to 0.15	B4S 18 – 20H B4S 36 – 22H
0.075	0.758	1.517	2.940	4.099	5.104	6.013	0.018	0.207	0.427	0.853	1.210	1.526	1.816	0.06 to 0.15	B4S 15 # 20H B4S 45 # 30H

# B

## Straight Bevel (SUS304)

Module 0.8/1/1.5/2

Gear Ratio 1 : 2



Unit: mm

Accuracy Class	Material	Pressure angle	Heat treatment	Tooth surface hardness	Backlash ①
[JIS B 1704] 4	SUS304	20°	—	—	See the table below.

★ No surface treatment is applied. The allowable transfer capability table was prepared based on the assumption that the pinion is on the input side.

★ This allowable transfer capability table was prepared by using the formulas presented by the JGMA (Japan Gear Manufacturers Association). For the unit conversion method, refer to P. 20 in "References."

★ The values in parentheses below "Tip diameter  $d_a$ " are theoretical values. The actual maximum diameter is the value obtained after the teeth are chamfered parallel to the shaft center. (See Fig. 1.)

★ Gears with a [\*] are provided with two screw holes. No set screws are provided.

① This is a theoretical value obtained when a pair of gears of the same type and material are meshed with each other.

Catalogue number	Gear ratio	Number of teeth	Reference diameter	Tip diameter	As-sembly distance	Hole diameter	Hub diameter	Hub length	Hole length	Over-all length	Dis-tance from end face to tip	Face width	Screw		Tip angle	Counter-bore diameter (Reference value)	Weight
													2-M(120°)	ls			
<b>B80SU 20 * 5</b>	1 : 2	20	$\phi 16$	$\phi 17.43$	22.5	$\phi 5$	$\phi 12$	5.5	10	10.79	6.86	4.5	2-M3	2.5	29° 8'	$\phi 9.8$	8.8
<b>B80SU 40 * 6</b>		40	$\phi 32$	$\phi 32.72$	16.46	$\phi 6$	$\phi 20$	6	9.5	11.01	9.18	4.5	2-M4	3.5	66° 0'	$\phi 22.9$	33.2
<b>B1SU 20 - 6</b>		20	$\phi 20$	$\phi 21.79$	29.6	$\phi 6$	$\phi 16$	8.6	14	15.03	10.05	5.7	-	-	29° 8'	$\phi 12.1$	21.6
<b>B1SU 40 - 8</b>		40	$\phi 40$	$\phi 40.89$	21.8	$\phi 8$	$\phi 25$	8	13	15.02	12.69	5.7	-	-	66° 0'	$\phi 28.4$	72.6
<b>B1SU 20 * 6</b>		20	$\phi 20$	$\phi 21.79$	29.6	$\phi 6$	$\phi 16$	8.6	14	15.03	10.05	5.7	2-M4	4	29° 8'	$\phi 12.1$	20.8
<b>B1SU 40 * 8</b>		40	$\phi 40$	$\phi 40.89$	21.8	$\phi 8$	$\phi 25$	8	13	15.02	12.69	5.7	2-M5	4	66° 0'	$\phi 28.4$	70.4
<b>B1.5SU 18 - 8</b>		18	$\phi 27$	$\phi 29.68$	40.74	$\phi 8$	$\phi 22$	12.5	21	22.96	14.41	9.8	-	-	29°25'	$\phi 12.1$	60.0
<b>B1.5SU 36 - 10</b>		36	$\phi 54$	$\phi 55.34$	26.75	$\phi 10$	$\phi 30$	10	15.5	18.54	14.59	9.8	-	-	66°17'	$\phi 34.3$	141.3
<b>B2SU 18 - 10</b>		18	$\phi 36$	$\phi 37.81$ ( $\phi 39.58$ )	53.12	$\phi 10$	$\phi 28$	15.12	27	29	18.01	12.6	-	-	29°25'	$\phi 19.1$	131.0
<b>B2SU 36 - 12</b>		36	$\phi 72$	$\phi 72.15$ ( $\phi 73.79$ )	35.21	$\phi 12$	$\phi 36$	13	21	24.07	19	12.6	-	-	66°17'	$\phi 47.6$	316.2

# B

## Straight Bevel (Brass)

Module 0.5/0.8

Gear Ratio 1 : 2



Unit: mm

Accuracy Class	Material	Pressure angle	Heat treatment	Tooth surface hardness	Backlash ①
[JIS B 1704] 4	C3604B	20°	—	—	0.02 to 0.08

★ No surface treatment is applied. The allowable transfer capability table was prepared based on the assumption that the pinion is on the input side.

★ Gears with a [\*] are provided with two screw holes and two set screws.

① This is a theoretical value obtained when a pair of gears of the same type and material are meshed with each other.

Catalogue number	Gear ratio	Number of teeth	Reference diameter	Tip diameter	As-sembly distance	Hole diameter	Hub diameter	Hub length	Hole length	Over-all length	Dis-tance from end face to tip	Face width	Screw		Tip angle	Counter-bore diameter (Reference value)	Weight
													2-M(120°)	ls			
<b>B50B 20</b>	1 : 2	20	$\phi 10$	$\phi 10.89$	15.52	$\phi 3$	$\phi 8$	5	8	8.54	5.74	3.2	-	-	29° 8'	$\phi 5.6$	3.2
<b>B50B 40</b>		40	$\phi 20$	$\phi 20.45$	10.56	$\phi 4$	$\phi 12$	4	6.3	7.31	6.01	3.2	-	-	66° 0'	$\phi 13.5$	8.9
<b>B50B 20 * 3</b>		20	$\phi 10$	$\phi 10.89$	15.52	$\phi 3$	$\phi 8$	5	8	8.54	5.74	3.2	2-M2.5	2.5	29° 8'	$\phi 5.6$	3.0
<b>B50B 40 * 4</b>		40	$\phi 20$	$\phi 20.45$	10.56	$\phi 4$	$\phi 12$	4	6.3	7.31	6.01	3.2	2-M3	2	66° 0'	$\phi 13.5$	8.5
<b>B80B 20</b>		20	$\phi 16$	$\phi 17.43$	22.5	$\phi 5$	$\phi 12$	5.5	10	10.79	6.86	4.5	-	-	29° 8'	$\phi 9.8$	9.8
<b>B80B 40</b>		40	$\phi 32$	$\phi 32.72$	16.46	$\phi 6$	$\phi 20$	6	9.5	11.01	9.18	4.5	-	-	66° 0'	$\phi 22.9$	36.1

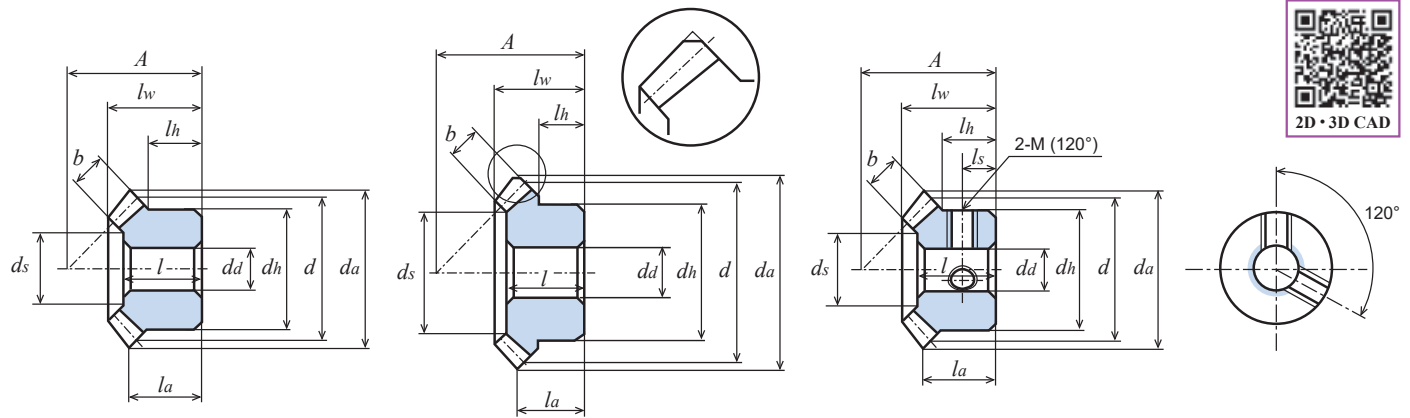
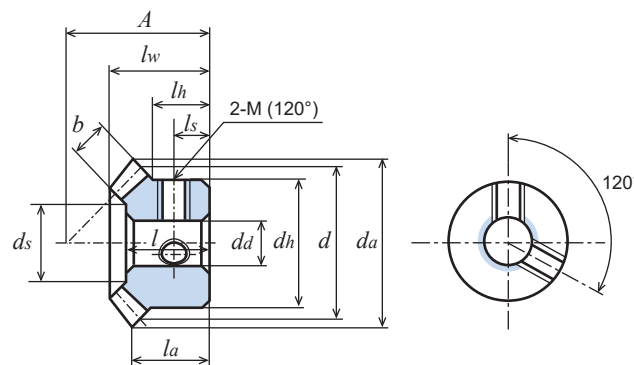

Fig. 1 (Tip chamfering)



2D • 3D CAD

Allowable transfer capability for different revolutions per minute Bending strength (Unit: W)							Backlash (Unit: mm)	Catalogue number
10rpm	100rpm	200rpm	400rpm	600rpm	800rpm	1,000rpm		
0.3	3.5	7.0	14.1	21.1	28.2	35.2	0.02 to 0.08	<b>B80SU 20 * 5</b> <b>B80SU 40 * 6</b>
0.6	6.9	13.9	27.8	41.7	55.6	69.1	0.05 to 0.12	<b>B1SU 20 – 6</b> <b>B1SU 40 – 8</b> <b>B1SU 20 * 6</b> <b>B1SU 40 * 8</b>
2.1	21.3	42.7	85.5	128.3	168.1	202.5	0.05 to 0.12	<b>B1.5SU 18 – 8</b> <b>B1.5SU 36 – 10</b>
4.9	49.5	99.1	198.3	292.2	370.9	442.4	0.05 to 0.12	<b>B2SU 18 – 10</b> <b>B2SU 36 – 12</b>





CONTENTS

INFORMATION

GEARBOXES

ANTI-BACKLASH  
SPUR GEARS

SPUR GEARS

RACKS

HELICAL GEARS AND  
SCREW GEARS

MITTER GEARS

**BEVEL GEARS**

WORMS AND WORM  
WHEELS

REFERENCES

# Worm gear sets

## W worm series

## G worm wheel series



\* These are samples

### How to Read Catalogue Numbers

**W 1 S R 1 + B - 8**

Gear type	Module	Material	Hand of helix	Number of threads	Hole finish	Shape	Hole diameter
W: Worm	Represents the module size. When the module is less than 1, the figure indicates a value 100 times the actual module size. Example: Module 0.5 → "50" Module 0.8 → "80"	S : S45C SU: Stainless steel SUS304	R: Right-hand L: Left-hand	1: Single thread of worm 2: Double thread of worm	Lathe turning finish [-]: No screw holes provided, no key grooves provided [+]: One screw hole provided [=]: Key groove provided	A : No hub provided B : Hub provided on one side B : Hub provided on both side CF: Hub provided on both side (Product for additional machining) L : Shafts provided on both sides	Unit: mm

**G 1 A 20 R 2 + 6**

Gear type	Module	Material	Number of teeth	Hand of helix	Number of thread for mating worm gear	Hole finish	Hole diameter
G: Worm wheel	Represents the module size. When the module is less than 1, the figure indicates a value 100 times the actual module size. Example: Module 0.5 → "50" Module 0.8 → "80"	B : Brass C3604B BP : Acetal Blue POM A : Aluminum bronze casting CAC702 Aluminum bronze C6191BE D : Acetal White POM DB: Acetal White POM (w/ brass C3604B bushing)	Example: When the number of teeth is 20: "20"	R: Right-hand L : Left-hand	1: Single thread of worm 2: Double thread of worm	Lathe turning finish [-]: No screw holes provided, no key grooves provided [+]: One screw hole provided [=]: Key groove provided	Unit: mm

(The catalog number differs slightly depending on the material.)

Catalogue number	W50	W50	G50	G50	G50	W80	W80	G80	G80	G80
Shape										
Page	P. 262	P. 263	P. 262	P. 262	P.262	P. 264	P. 265	P. 264	P. 264	P. 264
Material	SUS304	S45C	CAC702	Brass	Blue POM	SUS304	S45C	CAC702	Blue POM	White POM
Module	m0.5	m0.5	m0.5	m0.5	m0.5	m0.8	m0.8	m0.8	m0.8	m0.8
Teeth process sequence	Precision cold rolling	Precision cold rolling	Cutting	Cutting	Cutting	Precision cold rolling	Precision cold rolling	Cutting	Cutting	Cutting

Catalogue number	W1	W1	G1	G1	G1	W1.5	W1.5	G1.5	G1.5	G1.5
Shape										
Page	P. 266	P. 267	P. 266	P. 266	P. 268	P. 270	P. 271	P. 270	P. 270	P. 272
Material	SUS304	S45C	White POM / White POM (w/ brass bushing)	Blue POM	CAC702	SUS304	S45C	White POM / White POM (w/ brass bushing)	Blue POM	CAC702
Module	m1	m1	m1	m1	m1	m1.5	m1.5	m1.5	m1.5	m1.5
Teeth process sequence	Precision cold rolling	Precision cold rolling	Cutting	Cutting	Cutting	Precision cold rolling	Precision cold rolling	Cutting	Cutting	Cutting

Catalogue number	W2	G2	W2.5	G2.5	W3	G3
Shape						
Page	P. 274	P. 274	P. 276	P. 276	P. 277	P. 277
Material	S45C	CAC702	S45C	CAC702	S45C	CAC702
Module	m2	m2	m2.5	m2.5	m3	m3
Teeth process sequence	Precision cold rolling	Cutting	Cutting	Cutting	Cutting	Cutting

# Worm and Worm wheel information

## 1. Features of Worms and Worm Wheels

Machining method	Module	Tooth surface wear of worm wheel	Tooth surface roughness	Tooth surface hardness	Hardening
Cold rolling	0.5 to 2.0	Small	Cold-rolled surface Ra1.6	1.2 to 1.3 times larger than base material	Not possible
Cutting	2.5 to 3.0	Large	Cut surface Ra4.5	Base material hardness	Possible

A failure could occur if this product is used by using a product other than ours as the mating gear. If your device is designed with a product other than our standard products, consult with us.

### 1) Features of cold-rolled worms

#### ① Surface hardness:

Since cold-rolled worms are processed by cold rolling, they have enhanced thread surface hardness thanks to work hardening, and their metal fiber structure remains uncut. As a result, cold-rolled worms have better mechanical properties than cut worms.

The hardness of the thread surface after cold rolling increases 1.2-to 1.3-fold the hardness of the base material, and the hardness is HB240 to 260.

#### ② Surface roughness:

The thread surface has a mirror finish and the threads are rolled to form a completely curved surface.

#### ③ Extended worm wheel life

When a cold-rolled worm is used, since its thread surface has a mirror finish, the worm wheel lasts longer than when a cut worm is used.

#### ④ Compatibility with worm wheels made of polyacetal resin

Because of the above characteristics, cold-rolled worms reduce wear on worm wheels made of a soft material, such as polyacetal, providing the greatest durability.

#### ⑤ Maximum single pitch error and pressure angle error

The single pitch error and pressure angle error depend on the precision of the roll dice for cold rolling. The maximum adjacent error and pressure angle error of a cold-rolled worm is 18  $\mu$  m and  $\pm 20'$ , respectively.

#### ⑥ Cost performance

Compared with ground worms, which are expensive, cold-rolled worms are cost-effective with excellent surface roughness.

#### Cold rolling:

- ① Based on the principle of plastic deformation of materials, the material is placed between a pair of rollers, and the rollers are rotated while being hydraulically pressed with high pressure from both sides to process the material.
- ② Material: S45C, SUS304. (If a non-metallic material or other material is desired, consult with us.)
- ③ The thread pitch range is 0.5 mm to 2 mm.
- ④ When a cold-rolled worm is provided alone, the outside diameter and length are up to 40 mm and 80 mm, respectively.
- ⑤ If a special tooth profile is desired, consult with us.

### 2) Customization of ground worms

#### ① Overall accuracy:

Ground worms have excellent overall accuracy and are commonly used for machinery that requires high accuracy.

#### ② Production flow:

We offer a separate estimate based on your drawings.

# Worm and Worm wheel information

## 2. How to Select a Worm and Worm Wheel to be Meshed

Use a combination of a worm and a worm wheel having the same hand of helix and number of threads.

Compatible combination	Worm			
	R1	R2	L1	L2
Worm wheel	R1	R2	L1	L2

How to identify the hand of helix (right hand helix or left hand helix) of worms and worm wheels

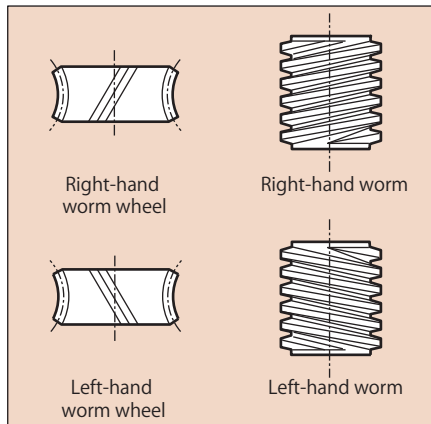

Actual samples

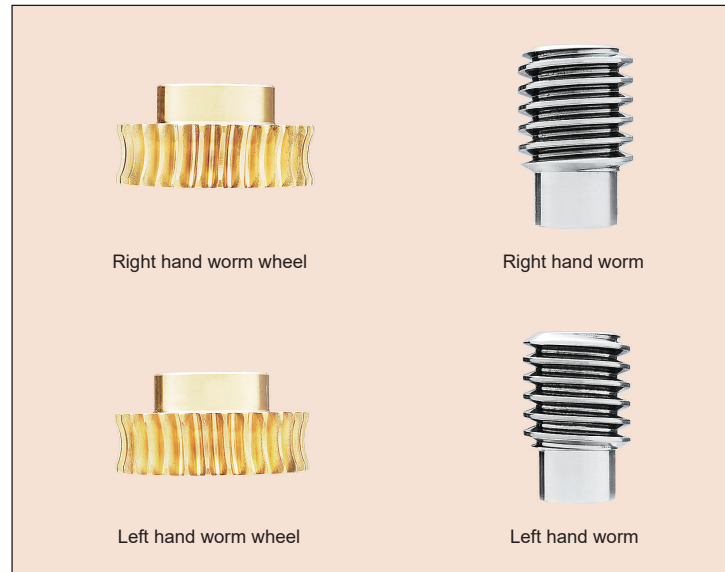

## 3. Cautions on Assembling a Worm and Worm Wheel

- 1) Accurate perpendicularity is the key to achieving ideal intermeshing.
- 2) The friction of tooth surfaces is large when a worm and a worm wheel are meshed. For the lubrication method, refer to 5. 4) on the next page.
- 3) To prevent the worm shaft and worm wheel shaft from bending, design the worm and worm wheel so that the bearings are tough and are located as close to the gears as possible.
- 4) Note that a large axial thrust acts on the worm. For more on axial thrust, see the figure of 4.
- 5) For more on tooth contact, refer to "Tooth Contacts of Gears" on P. 9 in "References."

# Worm and Worm wheel information

## 4. Axial thrust load to Worm gear and location of bearings.

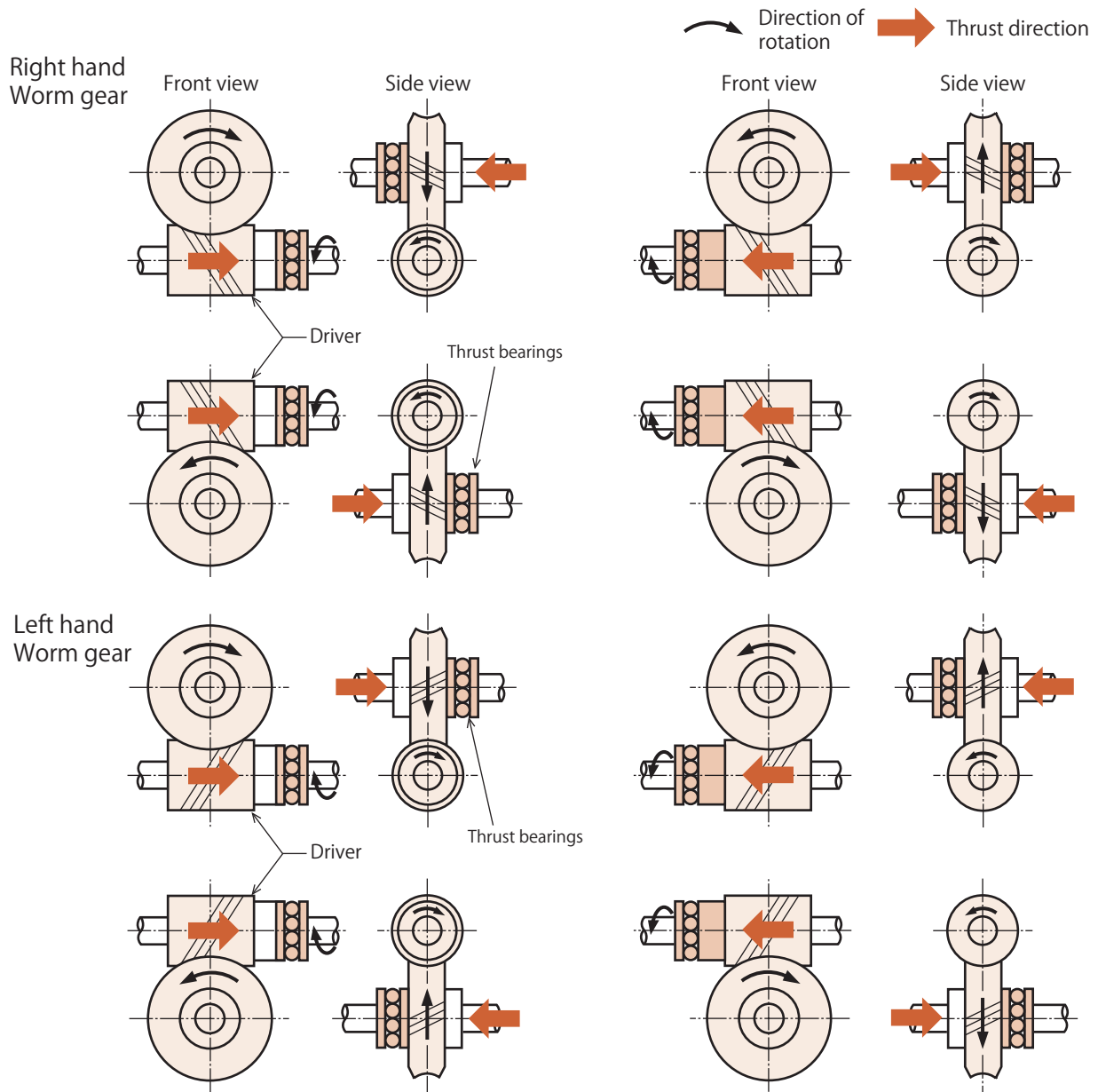

# Worm and Worm wheel information

## 5. Technical Information on Worms and Worm Wheels

### 1) Self-lock

Self-lock refers to the phenomenon in which a worm cannot be driven by the mating worm wheel. Theoretically, self-lock occurs when the lead angle is  $4^\circ$  or less. Self-lock may not occur depending mainly on the material, machining accuracy, lubricating oil, and effect of vibration.

\* To stop the worm and worm wheel without fail, provide a separate safety device.

### 2) Transfer efficiency

The theoretical transfer efficiency of our worm gears is 45 to 55% when the number of threads is one, and 55 to 65% when the number of threads is two. Use these values as reference values because the transfer efficiency depends mainly on the lubricating oil and revolutions per minute.

### 3) Backlash

Our gears are designed to have the backlash shown on the product description page when the gears are assembled with the assembly distance given in the catalogue. The amount of change in normal backlash due to changes in the intermeshing center distance can be calculated by the formula below.

This calculation formula is for our standard products with a pressure angle of  $20^\circ$ .

$$J_n = \Delta a / 1.46$$

$J_n$ : Amount of change in normal backlash

$\Delta a$ : Amount of change in the intermeshing center distance

### 4) Lubrication

One criterion for selecting the lubrication method is circumferential velocity. The circumferential velocity can be calculated as follows:

$$\text{* Circumferential velocity [m/s]} = \frac{\pi \times \text{Reference diameter [mm]} \times \text{Revolutions per minute [rpm]}}{1000 \times 60}$$

Lubrication method	Circumferential velocity (m/s)				
	0	5	10	15	20
Grease lubrication	→				
Splash lubrication	←				
Forced lubrication	←				

### Lubricating oil

- Purpose: To avoid contact between metallic gear teeth, to remove heat generated by friction between teeth, and to remove abrasion powder from the tooth surfaces. Lubricating oil may reduce vibration and noise.

- Appropriate amount of oil: Fig. 1 shows the amount of oil required to immerse the gear for reference.

The more of the gear is immersed, the larger the agitation resistance and windage loss (churning loss).

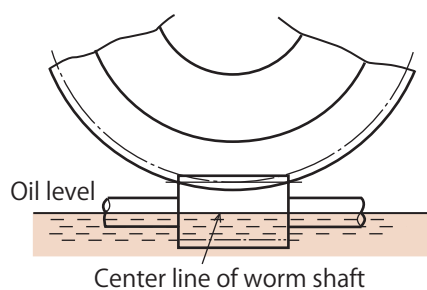

When the worm is used below the worm wheel, add oil until the oil level reaches half the worm diameter.

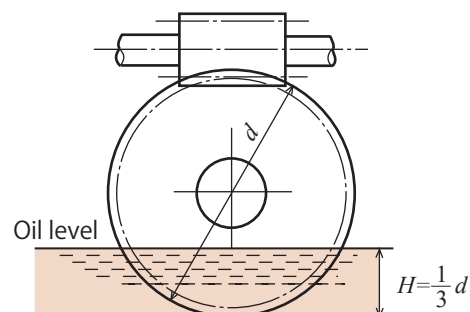

When the worm is used above the worm wheel, add oil until the oil level reaches 1/3 of the wheel diameter.

Fig. 1 Target amount of lubricating oil to be added

# W : Worm G : Worm Wheel



Example of use

Normal Module 0.5

(Full Depth Tooth)



Unit: mm

Accuracy Class	Material	Pressure angle	Teeth machining method
No relevant JIS	SUS304	20°	Precision cold rolling

★ No surface treatment is applied.

★ Gears with a [+] are provided with screw holes and set screws (Made of steel. Not stainless steel).

Catalogue number	Hand of helix	Number of threads	Reference diameter	Tip diameter	Type	Face width	Hole diameter	Hub diameter	Hub length	Overall length	Lead angle	Weight
		<i>z</i>	<i>d</i>	<i>d<sub>a</sub></i>		<i>b</i>	<i>d<sub>a</sub>(H8)</i>	<i>d<sub>h</sub></i>	<i>l<sub>h</sub></i>	<i>l</i>	<i>γ</i>	<i>W(g)</i>
<b>W50SU R1 + B</b>	R	1	φ9	φ10	B	13	φ3	φ7.6	5	18	3°11'	7.3



Unit: mm

Accuracy Class	Material	Pressure angle	Teeth machining method	Backlash ①
No relevant JIS	CAC702 (aluminum bronze casting)	20°	Cutting	See the table below

★ No surface treatment is applied. Gears with a [+] are provided with screw holes and set screws.

★ This allowable transfer capability table was prepared by using the formulas presented by the JGMA (Japan Gear Manufacturers Association). For the unit conversion method, refer to P. 20 in "References."

① Backlash when an appropriate combination of a worm and a worm wheel are meshed. (Backlash in the circumferential direction)

② Allowable torque value for the revolutions per minute of each worm.

Catalogue number	Gear ratio	Number of teeth	Inter-meshing pitch circle diameter	Rack shift coefficient	Throat diameter	Tip diameter	Type	Face width	Hole diameter	Hub diameter	Hub length	Overall length	Screw		Inter-meshing center distance	Hand of helix and number of threads of worm	Weight
													<i>M</i>	<i>l<sub>s</sub></i>			
	<i>u</i>	<i>z</i>	<i>u</i>	<i>z</i>	<i>u</i>	<i>z</i>		<i>b</i>	<i>d<sub>a</sub>(H8)</i>	<i>d<sub>h</sub></i>	<i>l<sub>h</sub></i>	<i>l</i>			<i>a</i>		<i>W(g)</i>
<b>G50A 20 + R1</b>	1 : 20	20	φ10	-0.015	φ11	φ11.45	1B	5	φ3	φ9	6	11	M3	3	9.5	R1	6.6
<b>G50A 30 + R1</b>	1 : 30	30	φ15	-0.023	φ16	φ16.45			φ4	φ12	6	11	M3	3	12		12.0
<b>G50A 40 + R1</b>	1 : 40	40	φ20	-0.031	φ21	φ21.45			φ5	φ15	8	13	M4	4	14.5		21.6
<b>G50A 50 + R1</b>	1 : 50	50	φ25	-0.038	φ26	φ26.45			φ5	φ20	8	13	M4	4	17		34.8
<b>G50A 60 + R1</b>	1 : 60	60	φ30	-0.046	φ31	φ31.45			φ5	φ25	8	13	M4	4	19.5		54.5
<b>G50A 80 + R1</b>	1 : 80	80	φ40	-0.061	φ41	φ41.45			φ6	φ30	8	13	M4	4	24.5		86.0



Unit: mm

Accuracy Class	Material	Pressure angle	Teeth machining method	Backlash ①
No relevant JIS	C3604B	20°	Cutting	See the table below

★ No surface treatment is applied. Gears with a [+] are provided with screw holes and set screws.

★ This allowable transfer capability table was prepared by using the formulas presented by the JGMA (Japan Gear Manufacturers Association). For the unit conversion method, refer to P. 20 in "References."

① Backlash when an appropriate combination of a worm and a worm wheel are meshed. (Backlash in the circumferential direction)

② Allowable torque value for the revolutions per minute of each worm.

Catalogue number	Gear ratio	Number of teeth	Inter-meshing pitch circle diameter	Rack shift coefficient	Throat diameter	Tip diameter	Type	Face width	Hole diameter	Hub diameter	Hub length	Overall length	Screw		Inter-meshing center distance	Hand of helix and number of threads of worm	Weight
													<i>M</i>	<i>l<sub>s</sub></i>			
	<i>u</i>	<i>z</i>	<i>d</i>	<i>x</i>	<i>d<sub>T</sub></i>	<i>d<sub>a</sub></i>		<i>b</i>	<i>d<sub>a</sub>(H8)</i>	<i>d<sub>h</sub></i>	<i>l<sub>h</sub></i>	<i>l</i>			<i>a</i>		<i>W(g)</i>
<b>G50B 20 + R1</b>	1 : 20	20	φ10	-0.015	φ11	φ11.45	1B	5	φ3	φ9	6	11	M3	3	9.5	R1	5.9
<b>G50B 30 + R1</b>	1 : 30	30	φ15	-0.023	φ16	φ16.45			φ4	φ12	6	11	M3	3	12.0		11.2
<b>G50B 40 + R1</b>	1 : 40	40	φ20	-0.031	φ21	φ21.45			φ5	φ15	8	13	M4	4	14.5		22.7
<b>G50B 50 + R1</b>	1 : 50	50	φ25	-0.038	φ26	φ26.45			φ5	φ16	8	13	M4	4	17.0		29.8



Unit: mm

Accuracy Class	Material	Pressure angle	Teeth machining method	Backlash ①
No relevant JIS	Blue POM	20°	Cutting	See the table below

★ This allowable transfer capability table was prepared by using the Lewis formula. For the unit conversion method, refer to P. 20 in "References."

★ Because of the material characteristics, the dimensions and accuracy change with time and due to temperature changes.

★ For details on blue POM, refer to P. 22.

① Backlash when an appropriate combination of a worm and a worm wheel are meshed. (Backlash in the circumferential direction)

② Allowable torque value for the revolutions per minute of each worm.

Catalogue number	Gear ratio	Number of teeth	Inter-meshing pitch circle diameter	Rack shift coefficient	Throat diameter	Tip diameter	Type	Face width	Hole diameter	Hub diameter	Hub length	Overall length	Inter-meshing center distance	Hand of helix and number of threads of worm	Weight
	<i>u</i>	<i>z</i>	<i>d</i>	<i>x</i>	<i>d<sub>T</sub></i>	<i>d<sub>a</sub></i>		<i>b</i>	<i>d<sub>a</sub></i>	<i>d<sub>h</sub></i>	<i>l<sub>h</sub></i>	<i>l</i>	<i>a</i>		<i>W(g)</i>
<b>G50BP 20 - R1</b>	1 : 20	20	φ10	-0.015	φ11	φ11.45	1B	5	φ3	φ9	6	11	9.5	R1	1.0
<b>G50BP 30 - R1</b>	1 : 30	30	φ15	-0.023	φ16	φ16.45			φ4	φ12	6	11	12.0		2.0
<b>G50BP 40 - R1</b>	1 : 40	40	φ20	-0.031	φ21	φ21.45			φ5	φ15	8	13	14.5		3.8
<b>G50BP 50 - R1</b>	1 : 50	50	φ25	-0.038	φ26	φ26.45			φ5	φ20	8	13	17.0		6.6
<b>G50BP 60 - R1</b>	1 : 60	60	φ30	-0.046	φ31	φ31.45			φ5	φ25	8	13	19.5		10.2
<b>G50BP 80 - R1</b>	1 : 80	80	φ40	-0.061	φ41	φ41.45			φ6	φ30	8	13	24.5		17.7

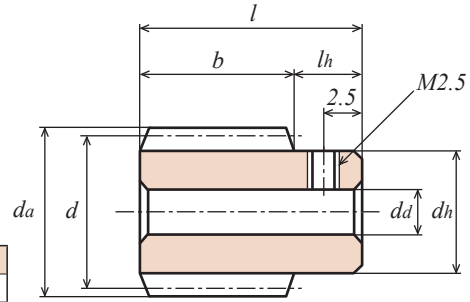

Unit: mm

Accuracy Class	Material	Pressure angle	Teeth machining method
No relevant JIS	S45C	20°	Precision cold rolling

- ★ No surface treatment is applied.
- ★ Gears with a [+] are provided with screw holes and set screws (Made of steel. Not stainless steel).

B type [+]

Catalogue number	Hand of helix	Number of threads	Reference diameter	Tip diameter	Type	Face width	Hole diameter	Hub diameter	Hub length	Overall length	Lead angle	Weight
		<i>z</i>	<i>d</i>	<i>da</i>		<i>b</i>	<i>da</i> (H8)	<i>dh</i>	<i>lh</i>	<i>l</i>	$\gamma$	<i>W</i> (g)
<b>W50S R1 + B</b>	R	1	$\phi 9$	$\phi 10$	B	13	$\phi 3$	$\phi 7.6$	5	18	3°11'	7.3

Allowable transfer torque of worm wheel for different revolutions per minute of worm (Unit: N · cm) Surface durability ②							Backlash ① (Unit: mm)	Catalogue number
100 rpm	250 rpm	500 rpm	1,000 rpm	1,200 rpm	1,500 rpm	1,800 rpm		
30.83	26.26	21.94	18.00	17.02	15.87	14.95	0.06 to 0.15	<b>G50A 20 + R1</b> <b>G50A 30 + R1</b> <b>G50A 40 + R1</b> <b>G50A 50 + R1</b> <b>G50A 60 + R1</b> <b>G50A 80 + R1</b>
66.07	57.03	48.36	39.95	37.87	35.39	33.44		
112.86	98.36	84.54	70.15	66.58	62.34	58.99		
170.92	150.05	129.89	108.41	103.00	96.57	91.46		
239.89	211.80	183.56	154.60	146.99	137.94	130.76		
409.47	362.63	316.59	270.27	257.25	241.75	229.44		

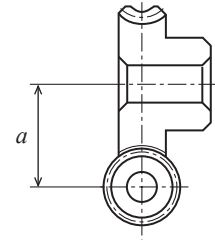

Allowable transfer torque of worm wheel for different revolutions per minute of worm (Unit: N · cm) Surface durability ②							Backlash ① (Unit: mm)	Catalogue number
100 rpm	250 rpm	500 rpm	1,000 rpm	1,200 rpm	1,500 rpm	1,800 rpm		
21.687	18.482	15.435	12.661	11.975	11.162	10.515	0.06 to 0.15	<b>G50B 20 + R1</b> <b>G50B 30 + R1</b> <b>G50B 40 + R1</b> <b>G50B 50 + R1</b>
46.452	40.111	34.015	28.096	26.636	24.892	23.520		
79.380	69.188	59.466	49.343	46.834	43.855	41.493		
120.226	105.546	91.365	76.263	72.451	67.923	64.337		

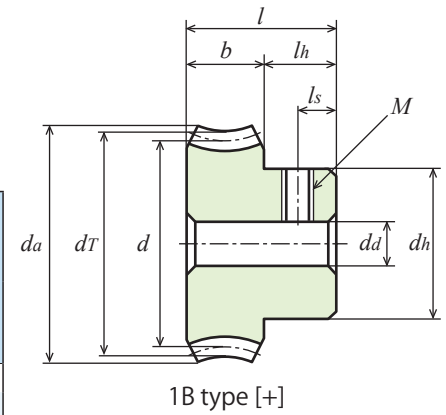

1B type [+]

Allowable transfer torque of worm wheel for different revolutions per minute of worm (Unit: N · cm) Surface durability ②							Backlash ① (Unit: mm)	Catalogue number
100 rpm	250 rpm	500 rpm	1,000 rpm	1,200 rpm	1,500 rpm	1,800 rpm		
9.00	9.00	9.00	9.00	8.94	8.94	8.87	0.06 to 0.15	<b>G50BP 20 - R1</b> <b>G50BP 30 - R1</b> <b>G50BP 40 - R1</b> <b>G50BP 50 - R1</b> <b>G50BP 60 - R1</b> <b>G50BP 80 - R1</b>
13.50	13.50	13.50	13.41	13.41	13.41	13.31		
18.01	18.01	18.01	18.01	17.88	17.88	17.75		
22.50	22.50	22.50	22.50	22.34	22.34	22.19		
27.00	27.00	27.00	27.00	26.82	26.82	26.63		
32.15	32.15	32.15	32.03	32.03	31.92	31.92		

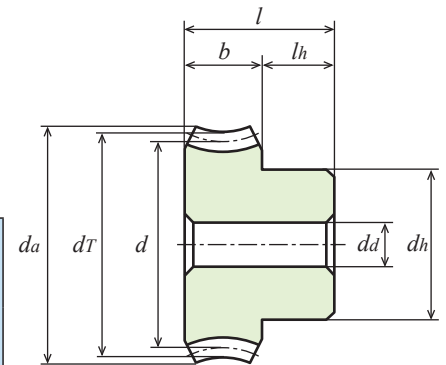

1B type [-]



# W : Worm G : Worm Wheel



Normal Module 0.8

(Full Depth Tooth)



Unit: mm

Accuracy Class	Material	Pressure angle	Teeth machining method
No relevant JIS	SUS304	20°	Precision cold rolling

- ★ No surface treatment is applied.
- ★ For gears with a [+], screw holes are provided, but no set screws are provided.

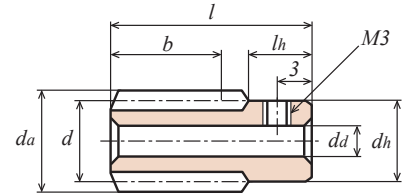

B type [+]

Catalogue number	Hand of helix	Number of threads	Reference diameter	Tip diameter	Type	Face width	Hole diameter	Hub diameter	Hub length		Overall length	Lead angle	Weight
									lhL	lhR			
<b>W80SU R1 + B</b>	R	1	φ10.4	φ12	B	14	φ5	φ10.3	-	6	26	4°24'	18.0
<b>W80SU R1 - L</b>	R	1	φ10.4	φ12	L	20	-	φ8 (h9)	20	40	80	4°24'	40.0



Unit: mm

Accuracy Class	Material	Pressure angle	Teeth machining method	Backlash ①
No relevant JIS	CAC702 (aluminum bronze casting) C6191BE (aluminum bronze)	20°	Cutting	See the table below

- ★ No surface treatment is applied. Gears with a [+ ] are provided with screw holes and set screws.
- ★ This allowable transfer capability table was prepared by using the formulas presented by the JGMA (Japan Gear Manufacturers Association). For the unit conversion method, refer to P. 20 in "References."

- ① Backlash when an appropriate combination of a worm and a worm wheel are meshed. (Backlash in the circumferential direction)
- ② Allowable torque value for the revolutions per minute of each worm.

Catalogue number	Gear ratio	Number of teeth	Inter-meshing pitch circle diameter	Rack shift coefficient	Throat diameter	Tip diameter	Type	Face width	Hole diameter	Hub diameter	Hub length	Overall length	Screw		Inter-meshing center distance	Hand of helix and number of threads of worm	Weight
													M	ls			
<b>G80A 20 + R1</b>	1 : 20	20	φ16	-0.029	φ17.6	φ18.1	1B	6	φ5	φ12	6	12	M3	3	13.2	R1	12.9
<b>G80A 30 + R1</b>	1 : 30	30	φ24	-0.044	φ25.6	φ26.1			φ5	φ16	6	12	M3	3	17.2		26.5
<b>G80A 40 + R1</b>	1 : 40	40	φ32	-0.059	φ33.6	φ34.1			φ6	φ18	8	14	M4	4	21.2		50.7
<b>G80A 50 + R1</b>	1 : 50	50	φ40	-0.074	φ41.6	φ42.1			φ6	φ20	8	14	M4	4	25.2		75.7
<b>G80A 60 + R1</b>	1 : 60	60	φ48	-0.089	φ49.6	φ50.2			φ8	30	8	14	M4	4	29.2		121.1
<b>G80A 80 + R1</b>	1 : 80	80	φ64	-0.119	φ65.6	φ66.2			φ8	40	8	14	M4	4	37.2		214.3



Unit: mm

Accuracy Class	Material	Pressure angle	Teeth machining method	Backlash ①
No relevant JIS	Blue POM	20°	Cutting	See the table below

- ★ This allowable transfer capability table was prepared by using the Lewis formula. For the unit conversion method, refer to P. 20 in "References."
- ★ Because of the material characteristics, the dimensions and accuracy change with time and due to temperature changes.
- ★ For details on blue POM, refer to P. 22.

- ① Backlash when an appropriate combination of a worm and a worm wheel are meshed. (Backlash in the circumferential direction)
- ② Allowable torque value for the revolutions per minute of each worm.

Catalogue number	Gear ratio	Number of teeth	Inter-meshing pitch circle diameter	Rack shift coefficient	Throat diameter	Tip diameter	Type	Face width	Hole diameter	Hub diameter	Hub length	Overall length	Screw		Inter-meshing center distance	Hand of helix and number of threads of worm	Weight
													M	ls			
<b>G80BP 20 - R1</b>	1 : 20	20	φ16	-0.029	φ17.6	φ18.1	1B	6	φ4	φ12	6	12	-	-	13.2	R1	2.4
<b>G80BP 30 - R1</b>	1 : 30	30	φ24	-0.044	φ25.6	φ26.1			φ5	φ18	6	12	-	-	17.2		5.6
<b>G80BP 40 - R1</b>	1 : 40	40	φ32	-0.059	φ33.6	φ34.1			φ6	φ20	8	14	-	-	21.2		9.8
<b>G80BP 50 - R1</b>	1 : 50	50	φ40	-0.074	φ41.6	φ42.1			φ6	φ25	8	14	-	-	25.2		15.5
<b>G80BP 60 - R1</b>	1 : 60	60	φ48	-0.089	φ49.6	φ50.1			φ8	φ30	8	14	-	-	29.2		22.2
<b>G80BP 80 - R1</b>	1 : 80	80	φ64	-0.119	φ65.6	φ66.2			φ8	φ40	8	14	-	-	37.2		42.4



Unit: mm

Accuracy Class	Material	Pressure angle	Teeth machining method	Backlash ①
No relevant JIS	White POM	20°	Cutting	See the table below

- ★ Gears with a [+ ] are provided with screw holes and set screws.
- ★ This allowable transfer capability table was prepared by using the Lewis formula. For the unit conversion method, refer to P. 20 in "References."
- ★ For the allowable torque value and backlash of this product, check the values for the blue POM products.
- ★ Because of the material characteristics, the dimensions and accuracy change with time and due to temperature changes.

- ① Backlash when an appropriate combination of a worm and a worm wheel are meshed. (Backlash in the circumferential direction)
- ② Allowable torque value for the revolutions per minute of each worm.

Catalogue number	Gear ratio	Number of teeth	Inter-meshing pitch circle diameter	Rack shift coefficient	Throat diameter	Tip diameter	Type	Face width	Hole diameter	Hub diameter	Hub length	Overall length	Screw		Inter-meshing center distance	Hand of helix and number of threads of worm	Weight
													M	ls			
<b>G80D 20 + R1</b>	1 : 20	20	φ16	-0.029	φ17.6	φ18.1	1B	6	φ5	φ12	6	12	M3	3	13.2	R1	2.5
<b>G80D 30 + R1</b>	1 : 30	30	φ24	-0.044	φ25.6	φ26.1			φ5	φ16	6	12	M3	3	17.2		5.2
<b>G80D 40 + R1</b>	1 : 40	40	φ32	-0.059	φ33.6	φ34.1			φ6	φ18	8	14	M4	4	21.2		10.0
<b>G80D 50 + R1</b>	1 : 50	50	φ40	-0.074	φ41.6	φ42.1			φ6	φ20	8	14	M4	4	25.2		14.0

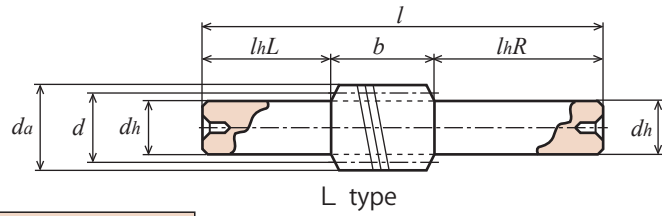

Unit: mm

Accuracy Class	Material	Pressure angle	Teeth machining method
No relevant JIS	S45C	20°	Precision cold rolling

- ★ No surface treatment is applied.
- ★ Gears with a [+] are provided with screw holes and set screws (Made of steel. Not stainless steel).

Catalogue number	Hand of helix	Number of threads	Reference diameter	Tip diameter	Type	Face width	Hole diameter	Hub diameter	Hub length		Overall length	Lead angle	Weight
									lhL	lhR			
<b>W80S R1 + B</b>	R	1	$\phi 10.4$	$\phi 12$	B	14	$\phi 5$	$\phi 10.3$	-	6	26	4°24'	18.0
<b>W80S R1 - L</b>	R	1	$\phi 10.4$	$\phi 12$	L	20	-	$\phi 8 (h9)$	20	40	80	4°24'	40.0

Allowable transfer torque of worm wheel for different revolutions per minute of worm (Unit: N · m) Surface durability ②							Backlash ① (Unit: mm)	Catalogue number
100 rpm	250 rpm	500 rpm	1,000 rpm	1,200 rpm	1,500 rpm	1,800 rpm		
0.872	0.735	0.607	0.499	0.470	0.441	0.411	0.06 to 0.15	<b>G80A 20 + R1</b>
1.871	1.597	1.352	1.117	1.058	0.989	0.931		<b>G80A 30 + R1</b>
3.194	2.763	2.371	1.960	1.862	1.744	1.646		<b>G80A 40 + R1</b>
4.841	4.223	3.645	3.038	2.891	2.704	2.557		<b>G80A 50 + R1</b>
6.799	5.965	5.163	4.342	4.126	3.870	3.666		<b>G80A 60 + R1</b>
11.606	10.213	8.904	7.590	7.221	6.782	6.433		<b>G80A 80 + R1</b>

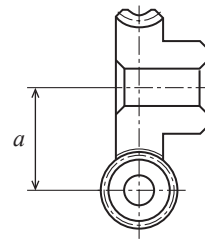

Allowable transfer torque of worm wheel for different revolutions per minute of worm (Unit: N · m) Surface durability ②							Backlash ① (Unit: mm)	Catalogue number
100 rpm	250 rpm	500 rpm	1,000 rpm	1,200 rpm	1,500 rpm	1,800 rpm		
0.28	0.28	0.28	0.27	0.27	0.27	0.27	0.06 to 0.15	<b>G80BP 20 - R1</b>
0.41	0.41	0.41	0.41	0.41	0.41	0.41		<b>G80BP 30 - R1</b>
0.55	0.55	0.55	0.55	0.55	0.55	0.55		<b>G80BP 40 - R1</b>
0.69	0.69	0.69	0.69	0.69	0.68	0.68		<b>G80BP 50 - R1</b>
0.83	0.83	0.83	0.82	0.82	0.82	0.82		<b>G80BP 60 - R1</b>
1.04	1.04	1.04	1.03	1.03	1.03	1.03		<b>G80BP 80 - R1</b>

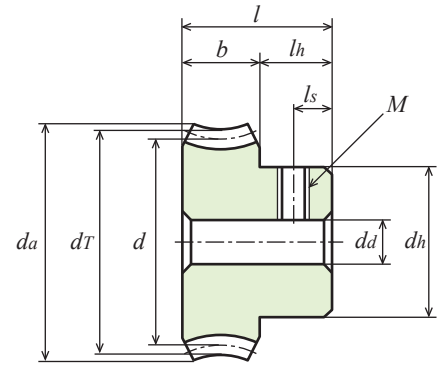

1B type [+]

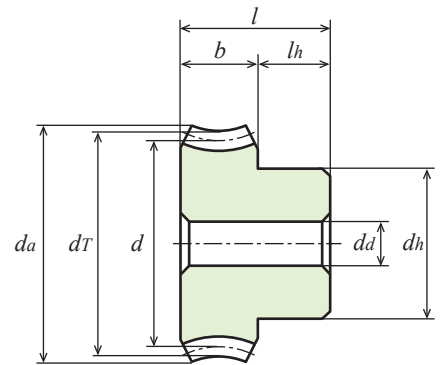

1B type [-]

# W : Worm G : Worm Wheel



Example of use

## Normal Module 1

## (Full Depth Tooth)



Unit: mm

Accuracy Class	Material	Pressure angle	Teeth machining method
No relevant JIS	SUS304	20°	Precision cold rolling

★ No surface treatment is applied. For gears with a [+], screw holes are provided, but no set screws are provided.

Catalogue number	Hand of helix	Number of threads	Reference diameter	Tip diameter	Type	Face width	Hole diameter	Hub diameter	Hub length	Overall length	Lead angle	Weight
		<i>z</i>	<i>d</i>	<i>d<sub>a</sub></i>		<i>b</i>	<i>d<sub>d</sub>(H8)</i>	<i>d<sub>h</sub></i>	<i>l<sub>h</sub></i>	<i>l</i>	<i>γ</i>	<i>W(g)</i>
<b>W1SU R1 + B</b>	R	1	φ16	φ18	B	15.5	φ6	φ15.85	7	32	3°35'	42.0
<b>W1SU R2 + B</b>	R	2	φ16	φ18	B	15	φ6	φ15.85	7	32	7°11'	42.0

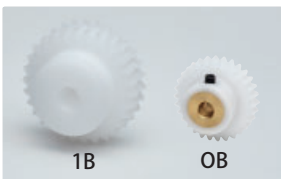

Unit: mm

Accuracy Class	Material	Pressure angle	Teeth machining method	Backlash ①
No relevant JIS	White POM ③	20°	Cutting	See the table below

Gears with a [+] are provided with screw holes and set screws. ★ Because of the material characteristics, the dimensions and accuracy change with time and due to temperature changes.

★ This allowable transfer capability table was prepared by using the Lewis formula. For the unit conversion method, refer to P. 20 in "References."

★ For the allowable torque value and backlash of this product, check the values for the blue POM products.

① Backlash when an appropriate combination of a worm and a worm wheel are meshed. (Backlash in the circumferential direction)

② Allowable torque value for the revolutions per minute of each worm.

③ The 1B products consist solely of white POM. The OB products consist of white POM and a brass (C3604B) bushing.

Catalogue number	Gear ratio	Number of teeth	Inter-meshing pitch circle diameter	Rack shift coefficient	Throat diameter	Tip diameter	Type	Face width	Hole diameter	Hub diameter	Hub length	Overall length	Inter-meshing center distance	Hand of helix and number of threads of worm	Weight
	<i>u</i>	<i>z</i>	<i>d</i>	<i>x</i>	<i>d<sub>T</sub></i>	<i>d<sub>a</sub></i>		<i>b</i>	<i>d<sub>d</sub>(H8)</i>	<i>d<sub>h</sub></i>	<i>l<sub>h</sub></i>	<i>l</i>	<i>a</i>		<i>W(g)</i>
<b>G1DB 20 + R2</b>	1 : 10	20	φ 20	-0.079	φ 22	φ 23	OB	8	φ 6	φ 16	9	17	18	R2	15.0
<b>G1DB 20 + R1</b>	1 : 20	20	φ 20	-0.019	φ 22	φ 23				φ 16			18	R1	15.0
<b>G1DB 30 + R1</b>	1 : 30	30	φ 30	-0.029	φ 32	φ 33				φ 20			23	R1	25.7
<b>G1D 20 - R2</b>	1 : 10	20	φ 20	-0.079	φ 22	φ 23.5	1B	10	φ 6	φ 17	8	18	18	R2	6.0
<b>G1D 20 - R1</b>	1 : 20	20	φ 20	-0.019	φ 22	φ 23.5			φ 6	φ 17			18	R1	6.0
<b>G1D 30 - R2</b>	1 : 15	30	φ 30	-0.118	φ 32	φ 33.5			φ 6	φ 22			23	R2	14.0
<b>G1D 30 - R1</b>	1 : 30	30	φ 30	-0.029	φ 32	φ 33.5			φ 6	φ 22			23	R1	14.0
<b>G1D 40 - R1</b>	1 : 40	40	φ 40	-0.039	φ 42	φ 43.5			φ 8	φ 25			28	R1	22.2
<b>G1D 50 - R1</b>	1 : 50	50	φ 50	-0.048	φ 52	φ 53.5			φ 8	φ 30			33	R1	34.7
<b>G1D 60 - R1</b>	1 : 60	60	φ 60	-0.058	φ 62	φ 63.5			φ 10	φ 30			38	R1	46.0
<b>G1D 80 - R1</b>	1 : 80	80	φ 80	-0.078	φ 82	φ 83.5			φ 10	φ 40			48	R1	84.0
<b>G1D 100 - R1</b>	1 : 100	100	φ 100	-0.098	φ 102	φ 103.5			φ 10	φ 40			58	R1	125.0



Unit: mm

Accuracy Class	Material	Pressure angle	Teeth machining method	Backlash ①
No relevant JIS	Blue POM	20°	Cutting	See the table below

★ This allowable transfer capability table was prepared by using the Lewis formula. For the unit conversion method, refer to P. 20 in "References."

★ Because of the material characteristics, the dimensions and accuracy change with time and due to temperature changes.

★ For details on blue POM, refer to P. 22.

① Backlash when an appropriate combination of a worm and a worm wheel are meshed. (Backlash in the circumferential direction)

② Allowable torque value for the revolutions per minute of each worm.

Catalogue number	Gear ratio	Number of teeth	Inter-meshing pitch circle diameter	Rack shift coefficient	Throat diameter	Tip diameter	Type	Face width	Hole diameter	Hub diameter	Hub length	Overall length	Inter-meshing center distance	Hand of helix and number of threads of worm	Weight
	<i>u</i>	<i>z</i>	<i>d</i>	<i>x</i>	<i>d<sub>T</sub></i>	<i>d<sub>a</sub></i>		<i>b</i>	<i>d<sub>d</sub></i>	<i>d<sub>h</sub></i>	<i>l<sub>h</sub></i>	<i>l</i>	<i>a</i>		<i>W(g)</i>
<b>G1BP 20 - R2</b>	1 : 10	20	φ 20	-0.079	φ 22	φ 23.5	1B	10	φ 5	φ 17	8	18	18	R2	6.8
<b>G1BP 20 - R1</b>	1 : 20	20	φ 20	-0.019	φ 22	φ 23.5			φ 5	φ 17			18	R1	6.8
<b>G1BP 30 - R2</b>	1 : 15	30	φ 30	-0.118	φ 32	φ 33.5			φ 6	φ 22			23	R2	13.9
<b>G1BP 30 - R1</b>	1 : 30	30	φ 30	-0.029	φ 32	φ 33.5			φ 6	φ 22			23	R1	13.9
<b>G1BP 40 - R1</b>	1 : 40	40	φ 40	-0.039	φ 42	φ 43.5			φ 8	φ 30			28	R1	24.9
<b>G1BP 50 - R1</b>	1 : 50	50	φ 50	-0.048	φ 52	φ 53.5			φ 8	φ 35			33	R1	37.8
<b>G1BP 60 - R1</b>	1 : 60	60	φ 60	-0.058	φ 62	φ 63.5			φ 8	φ 40			38	R1	53.4
<b>G1BP 80 - R1</b>	1 : 80	80	φ 80	-0.078	φ 82	φ 83.5			φ 10	φ 50			48	R1	91.7
<b>G1BP 100 - R1</b>	1 : 100	100	φ 100	-0.098	φ 102	φ 103.5			φ 10	φ 60			58	R1	141.3

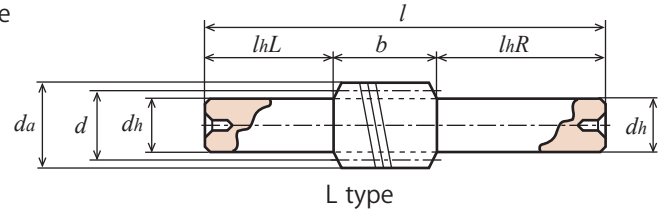
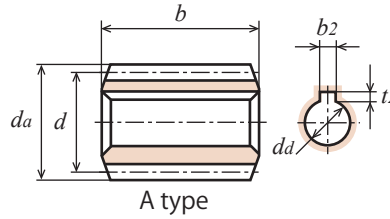
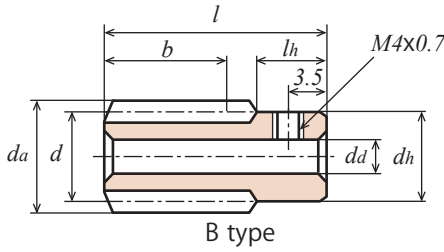

Unit: mm

Accuracy Class	Material	Pressure angle	Teeth machining method
No relevant JIS	S45C	20°	Precision cold rolling

★ No surface treatment is applied.

Gears with a [+] are provided with screw holes and set screws. Gears with a [-] are provided with key grooves and keys.

Catalogue number	Hand of helix	Number of threads z	Reference diameter d	Tip diameter da	Type	Face width b	Hole diameter da(H8)	Hub diameter dh	Hub length		Overall length l	Key groove b2 × t2	Lead angle γ	Weight W(g)
									lhL	lhR				
<b>W1S R1 = A</b>	R	1	φ16	φ18	A	25	φ8	-	-	-	25	3 × 1.4	3°35'	28.0
<b>W1S R1 + B</b>					B	17	φ6	φ15.85	-	7	32	-	3°35'	42.0
<b>W1S R1 + B - 8</b>					B	17	φ8	φ15.85	-	7	32	-	3°35'	42.0
<b>W1S R1 - L</b>					L	25	-	φ13(h8)	25	50	100	-	3°35'	120.0
<b>W1S R2 = A</b>	R	2	φ16	φ18	A	25	φ8	-	-	-	25	3 × 1.4	7°11'	28.0
<b>W1S R2 + B</b>					B	16.5	φ6	φ15.85	-	7	32	-	7°11'	42.0
<b>W1S R2 + B - 8</b>					B	16.5	φ8	φ15.85	-	7	32	-	7°11'	42.0
<b>W1S R2 - L</b>					L	25	-	φ13(h8)	25	50	100	-	7°11'	120.0
<b>W1S L1 = A</b>	L	1	φ16	φ18	A	25	φ8	-	-	-	25	3 × 1.4	3°35'	28.0
<b>W1S L1 + B</b>					B	17	φ6	φ15.85	-	7	32	-	3°35'	42.0
<b>W1S L1 - L</b>					L	25	-	φ13(h8)	25	50	100	-	3°35'	120.0
<b>W1S L2 + B</b>	L	2	φ16	φ18	B	16.5	φ6	φ15.85	-	7	32	-	7°11'	42.0
<b>W1S L2 - L</b>					L	25	-	φ13(h8)	25	50	100	-	7°11'	120.0

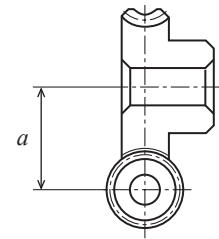
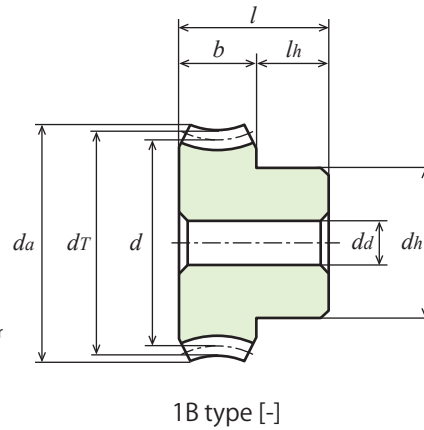
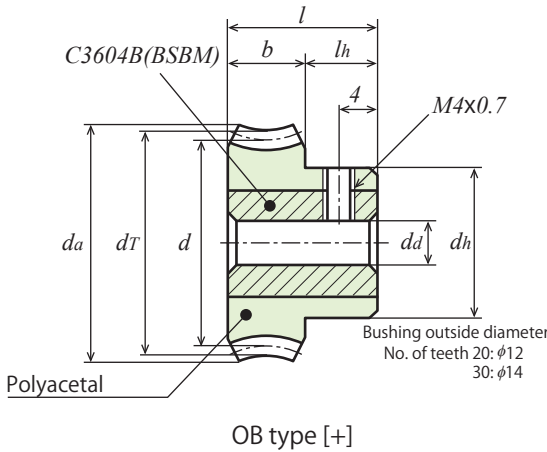

Allowable transfer torque of worm wheel for different revolutions per minute of worm (Unit: N · m)							Backlash ① (Unit: mm)	Catalogue number
Surface durability ②								
100 rpm	250 rpm	500 rpm	1,000 rpm	1,200 rpm	1,500 rpm	1,800 rpm		
0.63	0.63	0.63	0.63	0.62	0.62	0.62	0.08 to 0.20	<b>G1BP 20 - R2</b>
0.63	0.63	0.63	0.62	0.62	0.62	0.62		<b>G1BP 20 - R1</b>
0.95	0.95	0.95	0.94	0.93	0.93	0.93		<b>G1BP 30 - R2</b>
0.95	0.95	0.95	0.93	0.93	0.92	0.92		<b>G1BP 30 - R1</b>
1.26	1.26	1.26	1.24	1.24	1.23	1.23		<b>G1BP 40 - R1</b>
1.58	1.58	1.58	1.55	1.55	1.54	1.54		<b>G1BP 50 - R1</b>
1.89	1.89	1.89	1.86	1.86	1.85	1.85		<b>G1BP 60 - R1</b>
2.52	2.52	2.52	2.49	2.48	2.47	2.47		<b>G1BP 80 - R1</b>
3.15	3.15	3.15	3.11	3.10	3.08	3.08	0.15 to 0.30	<b>G1BP 100 - R1</b>

# W : Worm G : Worm Wheel



## Normal Module 1

## (Full Depth Tooth)

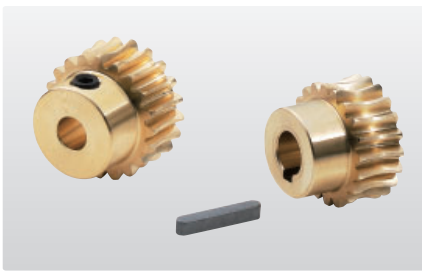

Unit: mm

Accuracy Class	Material	Pressure angle	Teeth machining method	Backlash ①
No relevant JIS	CAC702 (aluminum bronze casting) C6191BE (aluminum bronze)	20°	Cutting	See the table below

★ No surface treatment is applied. Gears with a [+ ] are provided with screw holes and set screws. Gears with a [= ] are provided with key grooves and keys.

★ This allowable transfer capability table was prepared by using the Lewis formula. For the unit conversion method, refer to P. 20 in "References."

① Backlash when an appropriate combination of a worm and a worm wheel are meshed. (Backlash in the circumferential direction)

② Allowable torque value for the revolutions per minute of each worm.

Catalogue number	Gear ratio	Number of teeth	Intermeshing pitch circle diameter	Rack shift coefficient	Throat diameter	Tip diameter	Type	Face width	Hole diameter	Hub diameter	Hub length	Overall length	Key groove	Intermeshing center distance	Hand of helix and number of threads of worm	Weight																		
	<i>u</i>	<i>z</i>	<i>d</i>	<i>x</i>	<i>d<sub>T</sub></i>	<i>d<sub>a</sub></i>		<i>b</i>	<i>d<sub>a</sub>(H8)</i>	<i>d<sub>h</sub></i>	<i>l<sub>h</sub></i>	<i>l</i>	<i>b<sub>2</sub> × t<sub>2</sub></i>	<i>a</i>		<i>W(g)</i>																		
<b>G1A 20R2+ 6</b>	1 : 10	20	φ20	-0.079	φ22	φ23.5	1B	10	φ 6	φ17	8	18	-	18	R2	35.0																		
<b>G1A 20R2+ 8</b>	1 : 10			-0.079					φ 8				-		R2	32.0																		
<b>G1A 20R2= 8</b>	1 : 10			-0.079					φ 8				3 × 1.4		R2	31.7																		
<b>G1A 20R1+ 6</b>	1 : 20			-0.019					φ 6				-		R1	35.0																		
<b>G1A 20R1+ 8</b>	1 : 20			-0.019					φ 8				-		R1	32.0																		
<b>G1A 20R1= 8</b>	1 : 20			-0.019					φ 8				3 × 1.4		R1	31.7																		
<b>G1A 20L2+ 6</b>	1 : 10			-0.079					φ 6				-		L2	35.0																		
<b>G1A 20L1+ 6</b>	1 : 20			-0.019					φ 6				-		L1	35.0																		
<b>G1A 30R2+ 6</b>	1 : 15	30	φ30	-0.118	φ32	φ33.5			1B	10			φ 6	φ22	8	18	-	23	R2	73.0														
<b>G1A 30R2+ 8</b>	1 : 15			-0.118									φ 8				-		R2	69.5														
<b>G1A 30R2= 10</b>	1 : 15			-0.118									φ10				3 × 1.4		R2	66.0														
<b>G1A 30R1+ 6</b>	1 : 30			-0.029									φ 6				-		R1	73.0														
<b>G1A 30R1+ 8</b>	1 : 30			-0.029									φ 8				-		R1	69.5														
<b>G1A 30R1= 10</b>	1 : 30			-0.029									φ10				3 × 1.4		R1	66.0														
<b>G1A 30L2+ 6</b>	1 : 15			-0.118									φ 6				-		L2	73.0														
<b>G1A 30L1+ 6</b>	1 : 30			-0.029									φ 6				-		L1	73.0														
<b>G1A 40R2+ 8</b>	1 : 20	40	φ40	-0.158	φ42	φ43.5							1B	10			φ 8	φ25	8	18	-	28	R2	121.0										
<b>G1A 40R1+ 8</b>	1 : 40			-0.039													φ 8				-		R1	121.0										
<b>G1A 40R1+ 10</b>	1 : 40			-0.039													φ10				-		R1	119.5										
<b>G1A 40R1= 10</b>	1 : 40			-0.039													φ10				3 × 1.4		R1	118.0										
<b>G1A 40L2+ 8</b>	1 : 20			-0.158													φ 8				-		L2	121.0										
<b>G1A 40L1+ 8</b>	1 : 40			-0.039													φ 8				-		L1	120.0										
<b>G1A 50R2+ 8</b>	1 : 25			50													φ50				-0.197		φ52	φ53.5	1B	10	φ 8	φ30	8	18	-	33	R2	190.0
<b>G1A 50R1+ 8</b>	1 : 50																				-0.048						φ 8				-		R1	190.0
<b>G1A 50R1+ 10</b>	1 : 50	-0.048	φ10		-	R1	187.5																											
<b>G1A 50R1= 12</b>	1 : 50	-0.048	φ12		4 × 1.8	R1	185.0																											
<b>G1A 50L2+ 8</b>	1 : 25	-0.197	φ 8		-	L2	190.0																											
<b>G1A 50L1+ 8</b>	1 : 50	-0.048	φ 8		-	L1	190.0																											



2D • 3D CAD

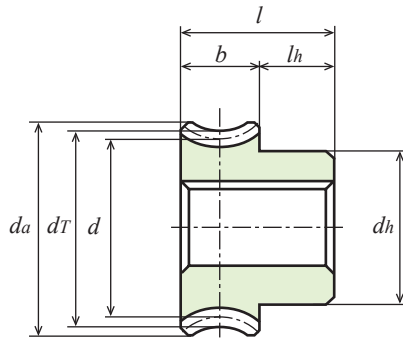

1B type [-]

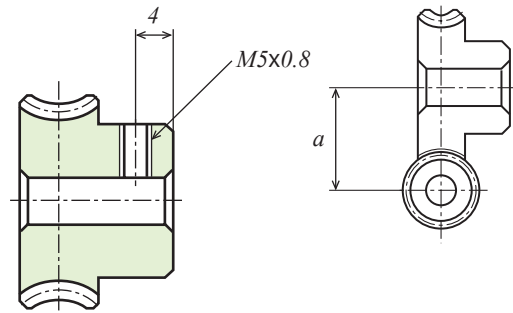
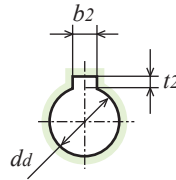

1B type [+]

Allowable transfer torque of worm wheel for different revolutions per minute of worm (Unit: N · m)							Backlash ① (Unit: mm)	Catalogue number
Surface durability ②								
100 rpm	250 rpm	500 rpm	1,000 rpm	1,200 rpm	1,500 rpm	1,800 rpm		
2.185	1.793	1.479	1.185	1.107	1.009	0.980	0.08 to 0.20	G1A 20R2 + 6
2.322	1.930	1.597	1.303	1.225	1.146	1.078		G1A 20R1 + 6
2.185	1.793	1.479	1.185	1.107	1.009	0.980		G1A 20L2 + 6
2.322	1.930	1.597	1.303	1.225	1.146	1.078		G1A 20L1 + 6
4.488	3.547	2.900	2.312	2.175	1.989	1.852		G1A 30R2 + 6
4.978	4.184	3.528	2.891	2.724	2.548	2.401		G1A 30R1 + 6
4.488	3.547	2.900	2.312	2.175	1.989	1.852		G1A 30L2 + 6
4.978	4.184	3.528	2.891	2.724	2.548	2.401		G1A 30L1 + 6
8.339	6.918	5.742	4.684	4.390	4.096	3.861		G1A 40R2 + 8
8.496	7.212	6.164	5.086	4.792	4.488	4.243		G1A 40R1 + 8
8.339	6.918	5.742	4.684	4.390	4.096	3.861		G1A 40L2 + 8
8.496	7.212	6.164	5.086	4.792	4.488	4.243		G1A 40L1 + 8
12.965	10.838	8.878	7.271	6.830	6.379	6.017		G1A 50R2 + 8
12.926	11.054	9.476	7.859	7.408	6.948	6.585		G1A 50R1 + 8
12.965	10.838	8.878	7.271	6.830	6.379	6.017		G1A 50L2 + 8
12.926	11.054	9.476	7.859	7.408	6.948	6.585		G1A 50L1 + 8

# W : Worm G : Worm Wheel



Example of use

Normal Module 1.5

(Full Depth Tooth)

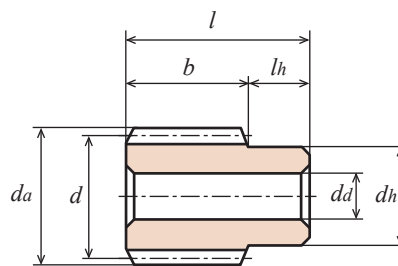

B type [-]

Unit: mm

Accuracy Class	Material	Pressure angle	Teeth machining method
No relevant JIS	SUS304	20°	Precision cold rolling

★ No surface treatment is applied.

Catalogue number	Hand of helix	Number of threads	Reference diameter	Tip diameter	Type	Face width	Hole diameter	Hub diameter	Hub length	Overall length	Lead angle	Weight
		<i>z</i>	<i>d</i>	<i>da</i>		<i>b</i>	<i>da(H8)</i>	<i>dh</i>	<i>lh</i>	<i>l</i>	$\gamma$	<i>W(g)</i>
<b>W1.5SU R1 – B</b>	R	1	φ25	φ28	B	30	φ10	φ20	13	43	3°26'	120.0
<b>W1.5SU R2 – B</b>		2									6°54'	

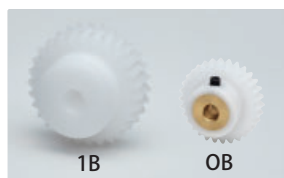

Unit: mm

Accuracy Class	Material	Pressure angle	Teeth machining method	Backlash ①
No relevant JIS	White POM ③	20°	Cutting	See the table below

★ This allowable transfer capability table was prepared by using the Lewis formula. For the unit conversion method, refer to P. 20 in "References."

★ For the allowable torque value and backlash of this product, check the values for the blue POM products.

★ Because of the material characteristics, the dimensions and accuracy change with time and due to temperature changes.

① Backlash when an appropriate combination of a worm and a worm wheel are meshed. (Backlash in the circumferential direction)

② Allowable torque value for the revolutions per minute of each worm.

③ The 1B products consist solely of white POM. The OB products consist of white POM and a brass (C3604B) bushing.

Catalogue number	Gear ratio	Number of teeth	Inter-meshing pitch circle diameter	Rack shift coefficient	Throat diameter	Tip diameter	Type	Face width	Hole diameter	Hub diameter	Hub length	Overall length	Inter-meshing center distance	Hand of helix and number of threads of worm	Weight
	<i>u</i>	<i>z</i>	<i>d</i>	<i>x</i>	<i>d<sub>T</sub></i>	<i>da</i>		<i>b</i>	<i>da</i>	<i>dh</i>	<i>lh</i>	<i>l</i>	<i>a</i>		<i>W(g)</i>
<b>G1.5DB 20 – R2</b>	1 : 10	20	φ30	-0.072	φ33	φ34.3	OB	10	φ 8	φ22	10	20	27.5	R2	35.0
<b>G1.5DB 20 – R1</b>	1 : 20			-0.018										R1	
<b>G1.5D 20 – R2</b>	1 : 10	20	φ30	-0.072	φ33	φ35.3	1B	15	φ 8	φ25	10	25	27.5	R2	21.0
<b>G1.5D 30 – R2</b>	1 : 15			30											



Unit: mm

Accuracy Class	Material	Pressure angle	Teeth machining method	Backlash ①
No relevant JIS	Blue POM	20°	Cutting	See the table below

★ This allowable transfer capability table was prepared by using the Lewis formula. For the unit conversion method, refer to P. 20 in "References."

★ Because of the material characteristics, the dimensions and accuracy change with time and due to temperature changes.

★ For details on blue POM, refer to P. 22.

① Backlash when an appropriate combination of a worm and a worm wheel are meshed. (Backlash in the circumferential direction)

② Allowable torque value for the revolutions per minute of each worm.

Catalogue number	Gear ratio	Number of teeth	Inter-meshing pitch circle diameter	Rack shift coefficient	Throat diameter	Tip diameter	Type	Face width	Hole diameter	Hub diameter	Hub length	Overall length	Inter-meshing center distance	Hand of helix and number of threads of worm	Weight	
	<i>u</i>	<i>z</i>	<i>d</i>	<i>x</i>	<i>d<sub>T</sub></i>	<i>da</i>		<i>b</i>	<i>da</i>	<i>dh</i>	<i>lh</i>	<i>l</i>	<i>a</i>		<i>W(g)</i>	
<b>G1.5BP 20 – R2</b>	1 : 10	20	φ30	-0.072	φ33	φ35.3	1B	15	φ 6	φ25	10	25	27.5	R2	22.0	
<b>G1.5BP 20 – R1</b>	1 : 20			-0.018					φ 6	φ25	10	25	27.5	R1	22.0	
<b>G1.5BP 30 – R2</b>	1 : 15	30	φ45	-0.109	φ48	φ50.3			φ 8	φ30	10	25	35	35	R2	43.4
<b>G1.5BP 30 – R1</b>	1 : 30	30	φ45	-0.027	φ48	φ50.3			φ 8	φ30	10	25	35	35	R1	43.4
<b>G1.5BP 40 – R1</b>	1 : 40	40	φ60	-0.036	φ63	φ65.3			φ10	φ40	13	28	28	42.5	R1	81.6
<b>G1.5BP 50 – R1</b>	1 : 50	50	φ75	-0.045	φ78	φ80.3			φ10	φ50	13	28	28	50	R1	128.5

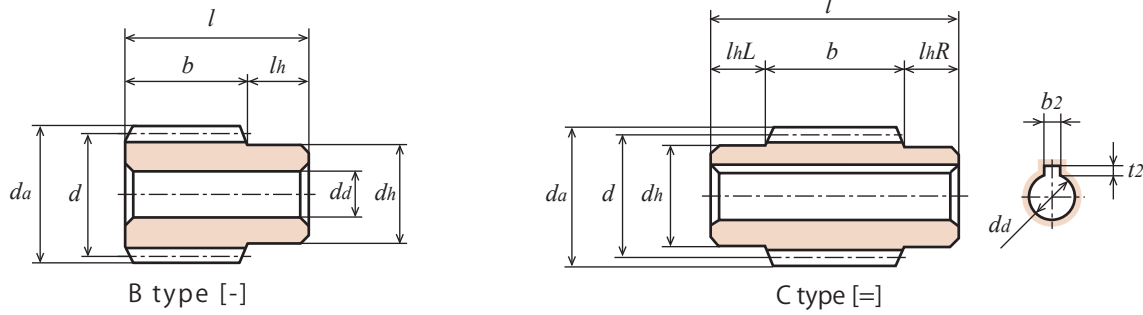

Unit: mm

Accuracy Class	Material	Pressure angle	Teeth machining method
No relevant JIS	S45C	20°	Precision cold rolling

★ No surface treatment is applied. Gears with a [=] are provided with key grooves and keys.

Catalogue number	Hand of helix	Number of threads <i>z</i>	Reference diameter <i>d</i>	Tip diameter <i>da</i>	Type	Face width <i>b</i>	Hole diameter <i>da(H8)</i>	Hub diameter <i>dh</i>	Hub length		Overall length <i>l</i>	Key groove <i>b2 × t2</i>	Lead angle <i>γ</i>	Weight <i>W(kg)</i>
									<i>lhL</i>	<i>lhR</i>				
<b>W1.5S R1 – B</b>	R	1	φ25	φ28	B	30	φ10	φ20	-	13	43	-	3°26'	0.12
<b>W1.5S R1 – CF</b>		C			35	φ12	10		10	55	-	3°26'	0.14	
<b>W1.5S R1 = C</b>		C			35	φ12	10		10	55	4 × 1.8	3°26'	0.13	
<b>W1.5S R2 – B</b>		B			30	φ10	-		13	43	-	6°54'	0.12	
<b>W1.5S R2 = C</b>	C	2	φ25	φ28	C	35	φ12	10	10	55	4 × 1.8	6°54'	0.13	
<b>W1.5S L1 – B</b>	L	1			B	30	φ10	-	13	43	-	3°26'	0.12	
<b>W1.5S L1 = C</b>		C			35	φ12	10	10	55	4 × 1.8	3°26'	0.13		
<b>W1.5S L2 – B</b>		B			30	φ10	-	13	43	-	6°54'	0.12		
<b>W1.5S L2 = C</b>		C	2	C	35	φ12	10	10	55	4 × 1.8	6°54'	0.13		

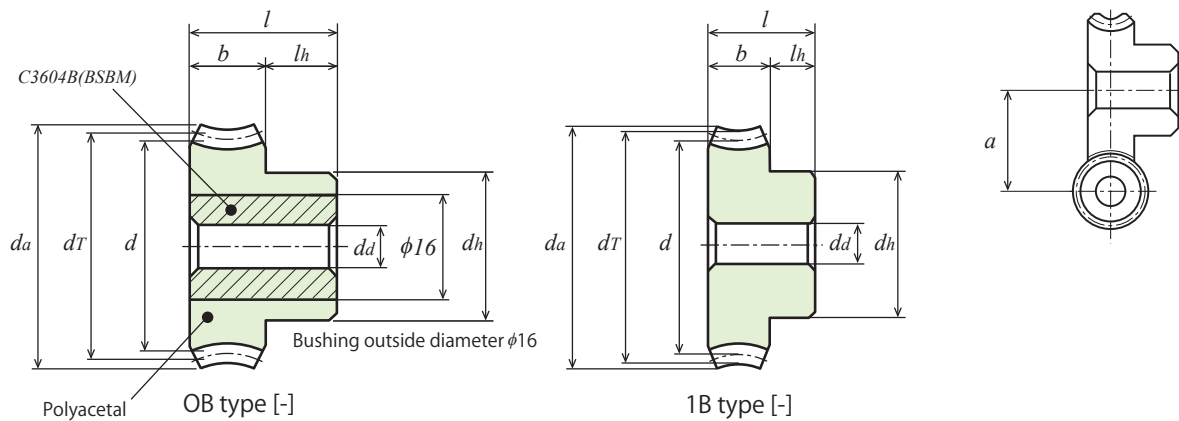

Allowable transfer torque of worm wheel for different revolutions per minute of worm (Unit: N · m) Surface durability ②							Backlash ① (Unit: mm)	Catalogue number
100 rpm	250 rpm	500 rpm	1,000 rpm	1,200 rpm	1,500 rpm	1,800 rpm		
1.22	1.22	1.21	1.20	1.20	1.19	1.19	0.08 to 0.20	<b>G1.5BP 20 – R2</b>
1.21	1.21	1.21	1.19	1.19	1.18	1.18		<b>G1.5BP 20 – R1</b>
1.83	1.83	1.82	1.79	1.79	1.79	1.78		<b>G1.5BP 30 – R2</b>
1.82	1.82	1.81	1.78	1.78	1.78	1.77		<b>G1.5BP 30 – R1</b>
2.43	2.43	2.41	2.38	2.38	2.37	2.36		<b>G1.5BP 40 – R1</b>
3.04	3.04	3.02	2.97	2.97	2.96	2.95		<b>G1.5BP 50 – R1</b>



# W : Worm G : Worm Wheel



Example of use

Normal Module 1.5

(Full Depth Tooth)



Unit: mm

Accuracy Class	Material	Pressure angle	Teeth machining method	Backlash ①
No relevant JIS	CAC702 (aluminum bronze casting) C6191BE (aluminum bronze)	20°	Cutting	See the table below

★ No surface treatment is applied. Gears with a [=] are provided with key grooves and keys.

★ This allowable transfer capability table was prepared by using the Lewis formula. For the unit conversion method, refer to P. 20 in "References."

① Backlash when an appropriate combination of a worm and a worm wheel are meshed. (Backlash in the circumferential direction)

② Allowable torque value for the revolutions per minute of each worm.

Catalogue number	Gear ratio	Number of teeth	Intermeshing pitch circle diameter	Rack shift coefficient	Throat diameter	Tip diameter	Type	Face width	Hole diameter	Hub diameter	Hub length	Overall length	Key groove	Intermeshing center distance	Hand of helix and number of threads of worm	Weight				
	$u$	$z$	$d$	$x$	$d_T$	$d_a$		$b$	$d_a(H8)$	$d_h$	$l_h$	$l$	$b_2 \times t_2$	$a$		$W(kg)$				
<b>G1.5A 20R2 – 8</b>	1 : 10	20	φ30	-0.072	φ33	φ35.3	1B	15	φ 8	φ25	10	25	-	27.5	R2	0.11				
<b>G1.5A 20R2 = 12</b>	1 : 10			-0.072					φ 12				4 × 1.8		R2	0.10				
<b>G1.5A 20R1 – 8</b>	1 : 20			-0.018					φ 8				-		R1	0.11				
<b>G1.5A 20R1 = 12</b>	1 : 20			-0.018					φ 12				4 × 1.8		R1	0.11				
<b>G1.5A 20L2 – 8</b>	1 : 10			-0.072					φ 8				-		L2	0.11				
<b>G1.5A 20L1 – 8</b>	1 : 20			-0.018					φ 8				-		L1	0.11				
<b>G1.5A 30R2 – 10</b>	1 : 15	30	φ45	-0.109	φ48	φ50.3			1B	15			φ10	φ30	10	25	-	35	R2	0.23
<b>G1.5A 30R1 – 10</b>	1 : 30			-0.027									φ10				-		R1	0.23
<b>G1.5A 30R1 = 15</b>	1 : 30			-0.027									φ15				5 × 2.3		R1	0.18
<b>G1.5A 30L1 – 10</b>	1 : 30			-0.027									φ10				-		L1	0.23

- CONTENTS
- INFORMATION
- GEARBOXES
- ANTI-BACKLASH SPUR GEARS
- SPUR GEARS
- RACKS
- HELICAL GEARS AND SCREW GEARS
- MITER GEARS
- BEVEL GEARS
- WORMS AND WORM WHEELS
- REFERENCES

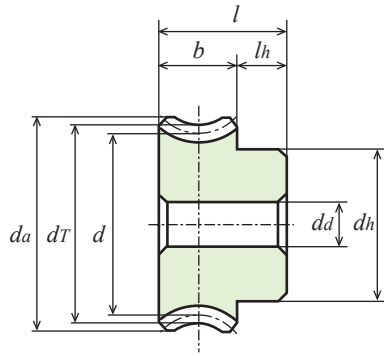

1B type [-]

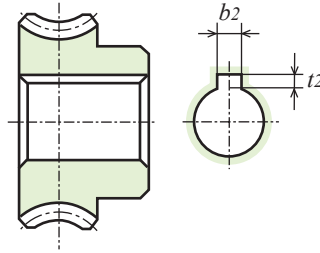

1B type [=]

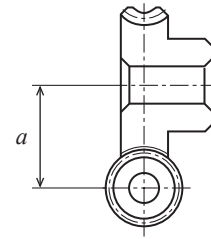

2D • 3D CAD

Allowable transfer torque of worm wheel for different revolutions per minute of worm (Unit: N · m)							Backlash ① (Unit: mm)	Catalogue number
Surface durability ②								
100 rpm	250 rpm	500 rpm	1,000 rpm	1,200 rpm	1,500 rpm	1,800 rpm		
6.801	5.370	4.390	3.498	3.273	3.008	2.802	0.08 to 0.20	<b>G1.5A 20R2 – 8</b>
7.036	5.762	4.762	3.851	3.635	3.381	3.185		<b>G1.5A 20R1 – 8</b>
6.801	5.370	4.390	3.498	3.273	3.008	2.802		<b>G1.5A 20L2 – 8</b>
7.036	5.762	4.762	3.851	3.635	3.381	3.185		<b>G1.5A 20L1 – 8</b>
14.700	11.858	9.741	7.830	7.389	6.840	6.409		<b>G1.5A 30R2 – 10</b>
15.092	12.544	10.486	8.545	8.085	7.546	7.114		<b>G1.5A 30R1 – 10</b>
15.092	12.544	10.486	8.545	8.085	7.546	7.114		<b>G1.5A 30L1 – 10</b>

# W : Worm G : Worm Wheel



## Normal Module 2

## (Full Depth Tooth)

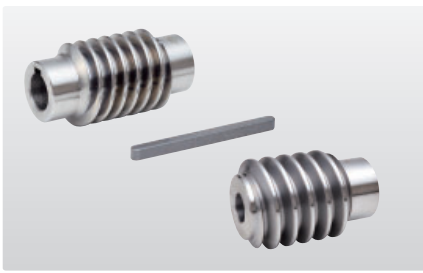

Unit: mm

Accuracy Class	Material	Pressure angle	Teeth machining method
No relevant JIS	S45C	20°	Precision cold rolling

★ No surface treatment is applied. Gears with a [=] are provided with key grooves and keys.

Catalogue number	Hand of helix	Number of threads <i>z</i>	Reference diameter <i>d</i>	Tip diameter <i>d<sub>a</sub></i>	Type	Face width <i>b</i>	Hole diameter <i>d<sub>a</sub>(H8)</i>	Hub diameter <i>d<sub>h</sub></i>	Hub length		Overall length <i>l</i>	Key groove <i>b<sub>2</sub> × t<sub>2</sub></i>	Lead angle <i>γ</i>	Weight <i>W(kg)</i>
									<i>l<sub>hL</sub></i>	<i>l<sub>hR</sub></i>				
<b>W2S R1 – B</b>	R	1	φ31	φ35	B	35	φ12	φ25	-	15	50	-	3°42'	0.22
<b>W2S R1 – CF</b>		1			C	41	φ14		12	12	65	-	3°42'	0.25
<b>W2S R1 = C</b>		1			C	41	φ14		12	12	65	5 × 2.3	3°42'	0.24
<b>W2S R2 – B</b>		2			B	35	φ12		-	15	50	-	7°25'	0.22
<b>W2S R2 = C</b>		2			C	41	φ14		12	12	65	5 × 2.3	7°25'	0.24



Unit: mm

Accuracy Class	Material	Pressure angle	Teeth machining method	Backlash ①
No relevant JIS	CAC702 (aluminum bronze casting)	20°	Cutting	See the table below

★ No surface treatment is applied. Gears with a [=] are provided with key grooves and keys.

★ This allowable transfer capability table was prepared by using the Lewis formula. For the unit conversion method, refer to P. 20 in "References."

① Backlash when an appropriate combination of a worm and a worm wheel are meshed. (Backlash in the circumferential direction)

② Allowable torque value for the revolutions per minute of each worm.

Catalogue number	Gear ratio	Number of teeth	Inter-meshing pitch circle diameter	Rack shift coefficient	Throat diameter	Tip diameter	Type	Face width	Hole diameter	Hub diameter	Hub length	Overall length	Key groove	Inter-meshing center distance	Hand of helix and number of threads of worm	Weight	
	<i>u</i>	<i>z</i>	<i>d</i>	<i>x</i>	<i>d<sub>T</sub></i>	<i>d<sub>a</sub></i>		<i>b</i>	<i>d<sub>a</sub>(H8)</i>	<i>d<sub>h</sub></i>	<i>l<sub>h</sub></i>	<i>l</i>	<i>b<sub>2</sub> × t<sub>2</sub></i>	<i>a</i>		<i>W(kg)</i>	
<b>G2A 20R2 – 10</b>	1 : 10	20	φ40	-0.084	φ 44	φ 47	1B	20	φ10	φ32	15	35	-	35.5	R2	0.26	
<b>G2A 20R2 = 15</b>	1 : 10			φ15					5 × 2.3				R2		0.23		
<b>G2A 20R1 – 10</b>	1 : 20			φ10					-				R1		0.26		
<b>G2A 20R1 = 15</b>	1 : 20			φ15					5 × 2.3				R1		0.23		
<b>G2A 20L2 – 10</b>	1 : 10			φ10					-				L2		0.26		
<b>G2A 20L1 – 10</b>	1 : 20			φ10					-				L1		0.26		
<b>G2A 25R1 – 12</b>	1 : 25	25	φ50	-0.026	φ 54	φ 57		φ12	φ38	-	φ40	15	35	-	40.5	R1	0.41
<b>G2A 25L1 – 12</b>	1 : 25	-	-	L1	0.41												
<b>G2A 30R2 – 12</b>	1 : 15	30	φ60	-0.126	φ 64	φ 67		1B	20	φ12	φ40	15	35	-	45.5	R2	0.56
<b>G2A 30R1 – 12</b>	1 : 30			φ12						-				R1		0.56	
<b>G2A 30R1 = 18</b>	1 : 30			φ18						6 × 2.8				R1		0.53	
<b>G2A 30L1 – 12</b>	1 : 30			φ12						-				L1		0.56	

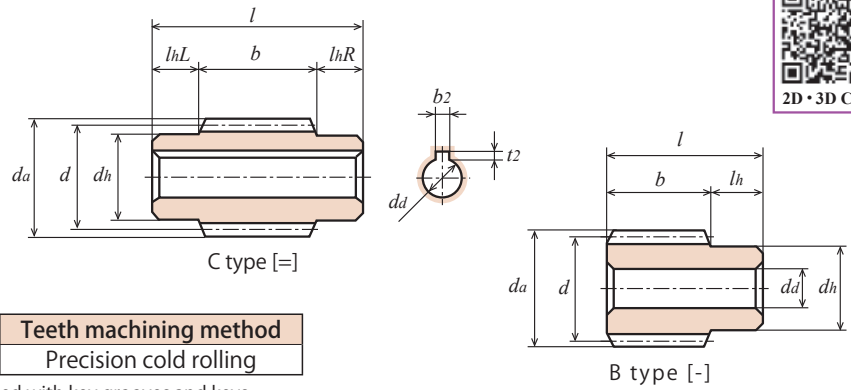

Unit: mm

Accuracy Class	Material	Pressure angle	Teeth machining method
No relevant JIS	S45C	20°	Precision cold rolling

★ No surface treatment is applied. Gears with a [=] are provided with key grooves and keys.

Catalogue number	Hand of helix	Number of threads $z$	Reference diameter $d$	Tip diameter $d_a$	Type	Face width $b$	Hole diameter $d_a(H8)$	Hub diameter $d_h$	Hub length		Overall length $l$	Key groove $b_2 \times t_2$	Lead angle $\gamma$	Weight $W(kg)$
									$l_{hL}$	$l_{hR}$				
W2S L1 – B	L	1	$\phi 31$	$\phi 35$	B	35	$\phi 12$	$\phi 25$	-	15	50	-	3°42'	0.22
W2S L1 = C					C	41	$\phi 14$		12	12	65	5 × 2.3	3°42'	0.24
W2S L2 – B		2			B	35	$\phi 12$		-	15	50	-	7°25'	0.22
W2S L2 = C					C	41	$\phi 14$		12	12	65	5 × 2.3	7°25'	0.24

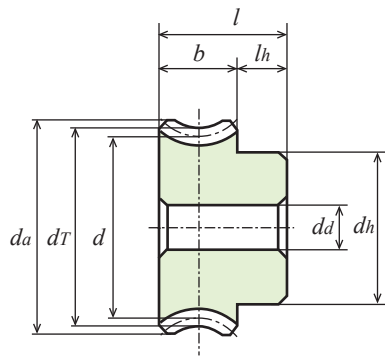

1B type [-]

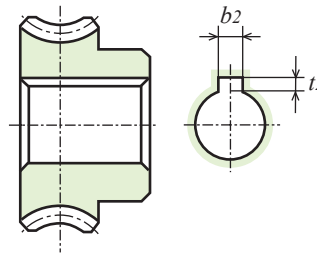

1B type [=]

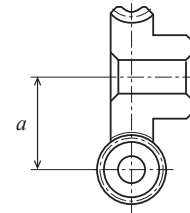

Allowable transfer torque of worm wheel for different revolutions per minute of worm (Unit: N · m)							Backlash ① (Unit: mm)	Catalogue number
Surface durability ②								
100 rpm	250 rpm	500 rpm	1,000 rpm	1,200 rpm	1,500 rpm	1,800 rpm		
14.504	11.466	9.310	7.350	6.860	6.370	5.880	0.08 to 0.20	G2A 20R2 – 10
14.949	12.250	10.094	8.134	7.644	7.154	6.664		G2A 20R1 – 10
14.504	11.466	9.310	7.350	6.860	6.370	5.880		G2A 20L2 – 10
12.936	12.250	10.094	8.134	7.644	7.154	6.664		G2A 20L1 – 10
22.932	18.816	15.582	12.642	11.956	11.172	10.486		G2A 25R1 – 12
22.932	18.816	15.582	12.642	11.956	11.172	10.486		G2A 25L1 – 12
32.144	26.656	22.246	18.130	17.150	15.974	14.994		G2A 30R1 – 12
32.144	26.656	22.246	18.130	17.150	15.974	14.994		G2A 30L1 – 12

# W : Worm G : Worm Wheel



Normal Module 2.5

(Full Depth Tooth)

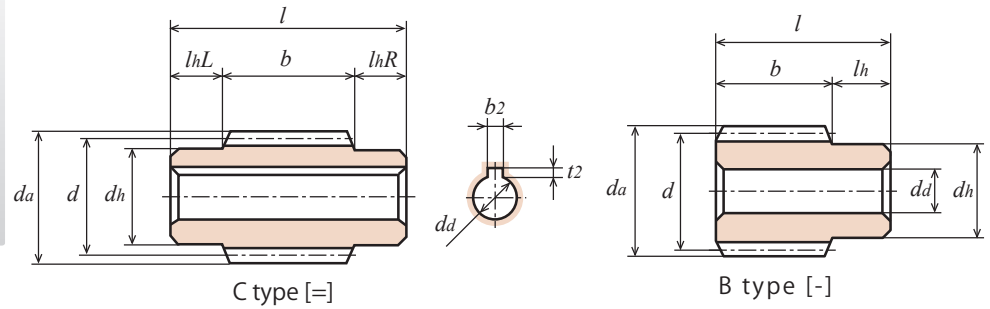
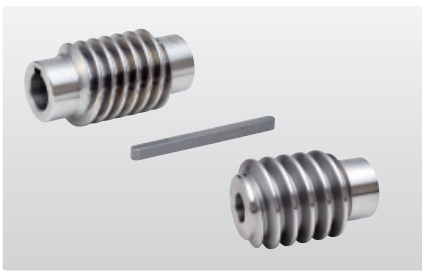

Unit: mm

Accuracy Class	Material	Pressure angle	Teeth machining method
No relevant JIS	S45C	20°	Cutting

★ No surface treatment is applied. Gears with a [=] are provided with key grooves and keys.

Catalogue number	Hand of helix	Number of threads <i>z</i>	Reference diameter <i>d</i>	Tip diameter <i>da</i>	Type	Face width <i>b</i>	Hole diameter <i>da(H8)</i>	Hub diameter <i>dh</i>	Hub length		Overall length <i>l</i>	Key groove <i>b2 × t2</i>	Lead angle <i>γ</i>	Weight <i>W(kg)</i>
									<i>lhL</i>	<i>lhR</i>				
<b>W2.5S R1 – B</b>	R	1	φ37	φ42	B	42	φ14	φ30	-	18	60	-	3°52'	0.37
<b>W2.5S R1 = C</b>		1			C	47	φ16		14	14	75	5 × 2.3	3°52'	0.41
<b>W2.5S R2 – B</b>		2			B	42	φ14		-	18	60	-	7°46'	0.37
<b>W2.5S R2 – CF</b>		2			C	47	φ16		14	14	75	-	7°46'	0.42
<b>W2.5S R2 = C</b>		2			C	47	φ16		14	14	75	5 × 2.3	7°46'	0.41
<b>W2.5S L1 – B</b>		L			1	B	42		φ14	-	18	60	-	3°52'

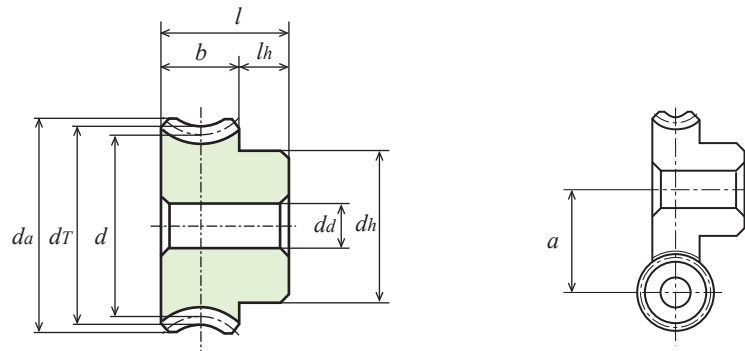

Unit: mm

1B type [-]

Accuracy Class	Material	Pressure angle	Teeth machining method	Backlash ①
No relevant JIS	CAC702 (aluminum bronze casting)	20°	Cutting	See the table below

★ No surface treatment is applied.

★ This allowable transfer capability table was prepared by using the Lewis formula. For the unit conversion method, refer to P. 20 in "References."

① Backlash when an appropriate combination of a worm and a worm wheel are meshed. (Backlash in the circumferential direction)

② Allowable torque value for the revolutions per minute of each worm.

Catalogue number	Gear ratio	Number of teeth	Inter-meshing pitch circle diameter	Rack shift coefficient	Throat diameter	Tip diameter	Type	Face width	Hole diameter	Hub diameter	Hub length	Overall length	Inter-meshing center distance	Hand of helix and number of threads of worm	Weight			
	<i>u</i>	<i>z</i>	<i>d</i>	<i>x</i>	<i>dT</i>	<i>da</i>		<i>b</i>	<i>da(H8)</i>	<i>dh</i>	<i>lh</i>	<i>l</i>	<i>a</i>		<i>W(kg)</i>			
<b>G2.5A 20R2 – 12</b>	1 : 10	20	φ 50	-0.092	φ 55	φ 58.8	1B	24	φ12	φ40	16	40	43.5	R2	0.50			
<b>G2.5A 20R1 – 12</b>	1 : 20			-0.022										R1	0.50			
<b>G2.5A 30R2 – 14</b>	1 : 15	30	φ 75	-0.138	φ 80	φ 83.8								φ14	φ50	56	R2	1.02
<b>G2.5A 30R1 – 14</b>	1 : 30			-0.034													R1	1.02
<b>G2.5A 30L1 – 14</b>	1 : 30			-0.034													L1	1.02

Catalogue number	Allowable transfer torque of worm wheel for different revolutions per minute of worm (Unit: N · m)								Backlash ① (Unit: mm)
	Surface durability ②								
	100 rpm	250 rpm	500 rpm	1,000 rpm	1,200 rpm	1,500 rpm	1,800 rpm		
<b>G2.5A 20R2 – 12</b>	26.166	20.580	16.758	13.328	12.446	11.368	10.486	0.08 to 0.20	
<b>G2.5A 20R1 – 12</b>	27.048	22.050	18.130	14.700	13.818	12.838	11.956		
<b>G2.5A 30R2 – 14</b>	56.448	45.276	37.142	29.792	28.028	25.970	24.010	0.15 to 0.3	
<b>G2.5A 30R1 – 14</b>	58.016	47.922	39.984	32.536	30.772	28.616	26.656		
<b>G2.5A 30L1 – 14</b>	58.016	47.922	39.984	32.536	30.772	28.616	26.656		

# W : Worm G : Worm Wheel



## Normal Module 3

## (Full Depth Tooth)

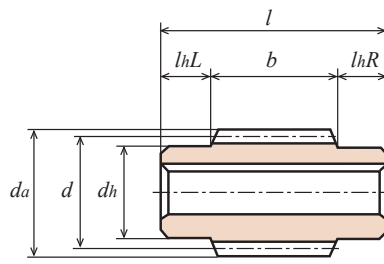
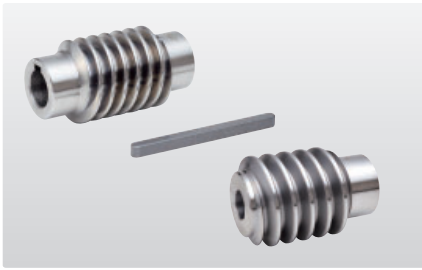

C type [=]

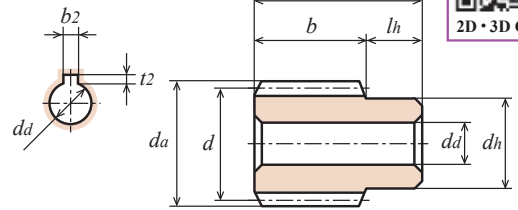

B type [-]



2D • 3D CAD

Unit: mm

Accuracy Class	Material	Pressure angle	Teeth machining method
No relevant JIS	S45C	20°	Cutting

★ No surface treatment is applied. Gears with a [=] are provided with key grooves and keys.

Catalogue number	Hand of helix	Number of threads <i>z</i>	Reference diameter <i>d</i>	Tip diameter <i>da</i>	Type	Face width <i>b</i>	Hole diameter <i>da(H8)</i>	Hub diameter <i>dh</i>	Hub length		Overall length <i>l</i>	Key groove <i>b2 × t2</i>	Lead angle <i>γ</i>	Weight <i>W(kg)</i>
									<i>lhL</i>	<i>lhR</i>				
W3S R1 – B	R	1	φ44	φ50	B	50	φ16	φ36	-	20	70	-	3°55'	0.62
W3S R1 – CF		1			C	55	φ20		15	15	85	-	3°55'	0.67
W3S R1 = C		1			C	55	φ20		15	15	85	6 × 2.8	3°55'	0.66
W3S R2 – B		2			B	50	φ16		-	20	70	-	7°50'	0.62
W3S R2 – CF		2			C	55	φ20		15	15	85	-	7°50'	0.67
W3S R2 = C		2			C	55	φ20		15	15	85	6 × 2.8	7°50'	0.66
W3S L1 – B	L	1			B	50	φ16		-	20	70	-	3°55'	0.62
W3S L1 = C					C	55	φ20		15	15	85	6 × 2.8	3°55'	0.66

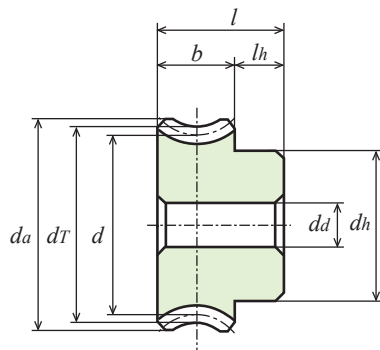

1B type [-]

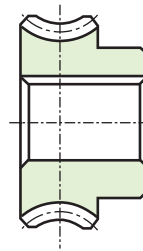

1B type [=]

Unit: mm

Accuracy Class	Material	Pressure angle	Teeth machining method	Backlash ①
No relevant JIS	CAC702 (aluminum bronze casting)	20°	Cutting	See the table below

★ No surface treatment is applied. Gears with a [=] are provided with key grooves and keys.

★ This allowable transfer capability table was prepared by using the Lewis formula. For the unit conversion method, refer to P. 20 in "References."

① Backlash when an appropriate combination of a worm and a worm wheel are meshed. (Backlash in the circumferential direction).

② Allowable torque value for the revolutions per minute of each worm.

Catalogue number	Gear ratio <i>u</i>	Number of teeth <i>z</i>	Inter-meshing pitch circle diameter <i>d</i>	Rack shift coefficient <i>x</i>	Throat diameter <i>dr</i>	Tip diameter <i>da</i>	Type	Face width <i>b</i>	Hole diameter <i>da(H8)</i>	Hub diameter <i>dh</i>	Hub length <i>lh</i>	Overall length <i>l</i>	Key groove <i>b2 × t2</i>	Inter-meshing center distance <i>a</i>	Hand of helix and number of threads of worm	Weight <i>W(kg)</i>
G3A 20R2 – 16	10	20	φ 60	-0.094	φ 66	φ 70.5	1B	28	φ16	φ48	17	45	-	52	R2	0.80
G3A 20R1 – 16	20	20		-0.023					φ16				-		R1	0.80
G3A 20R1 = 20				φ20					6 × 2.8				R1		0.77	
G3A 20L1 – 16				φ16					-				L1		0.80	
G3A 25R1 – 16	25	25	φ 75	-0.029	φ 81	φ 85.5		φ16	φ55				59.5	R1	1.22	
G3A 25L1 – 16								-						L1	1.22	

Catalogue number	Allowable transfer torque of worm wheel for different revolutions per minute of worm (Unit: N • m)								Backlash ① (Unit: mm)
	Surface durability ②								
	100 rpm	250 rpm	500 rpm	1,000 rpm	1,200 rpm	1,500 rpm	1,800 rpm		
G3A 20R2 – 16	42.532	33.418	26.950	21.560	20.188	18.228	16.758	0.15 to 0.30	
G3A 20R1 – 16	44.100	35.868	29.302	23.716	22.344	20.580	19.012		
G3A 20L1 – 16	44.100	35.868	29.302	23.716	22.344	20.580	19.012		
G3A 25R1 – 16	67.326	55.076	45.276	36.848	34.790	31.948	29.694		
G3A 25L1 – 16	67.326	55.076	45.276	36.848	34.790	31.948	29.694		

# Memo

CONTENTS

INFORMATION

GEARBOXES

ANTI-BACKLASH  
SPUR GEARS

SPUR GEARS

RACKS

HELICAL GEARS AND  
SCREW GEARS

MITTER GEARS

BEVEL GEARS

**WORMS AND WORM  
WHEELS**

REFERENCES

# References (for KG Metric gears)

For detailed information on gears, please refer to the separate "Technical Data"



## Contents

<b>1. Fundamental dimensions for various sizes of Tooth profile</b>	1
(1) Module $m$ (Unit: mm)	1
(2) Diametral pitch $P$ or $DP$	1
(3) Circular pitch $CP$	1
<b>2. Advise on gear assembly</b>	3
<b>3. Centre distance for spur and helical gears</b>	4
(1) Accuracy standard for spur and helical gears	4
(2) Centre distance: Shortest distance from centre of axes of Parallel spur gear pair or gear pair with Non-parallel and Non-intersecting axes.	4
<b>4. Parallelism of axis for spur and helical gears</b>	4
(1) Application range	4
(2) Definition of terms	5
(3) Allowable value	5
<b>5. Measurement of the backlash</b>	7
(1) Backlash of Bevel gear pair	7
(2) Backlash of Worm gear pair	8
<b>6. Tooth bearings</b>	9
<b>7. Gear efficiency</b>	11
<b>8. Lubricating oil for gears</b>	12
(1) Purpose of using lubricating oil	12
(2) Method of lubricating oil	12
(3) Proper level of lubricating oil	13
(4) Features of Polyacetal gear	14
(5) Combination of gear materials	14
<b>9. Cause and solution for noise and oscillation</b>	15
<b>10. The vocabulary of gear and gear terms</b>	16



<b>11. Interpretation of Allowable capability torque table.</b> .....	17
(1) Bending Strength and Surface Durability for Spur and Helical gears. ....	17
(2) Bending strength and Surface durability for Bevel gears. ....	18
(3) Surface durability of Cylindrical worm gear pair. ....	18
<b>12. While examination of Bending strength from the Allowable transfer capability table</b> .....	19
For example 1. To calculate Allowable transfer torque: $T[N.m]$ .....	19
For example 2. To select KG-STOCK GEARS from usage condition of Spur gear. ....	20
The Conversion formula of Power .....	20
<b>13. Conversion table for SI units (International System of Units)</b> .....	21
<b>14. Standardizing the coordination between ISO and JIS</b> .....	22
Introduction .....	22
Precision of KG STOCK GEARS. ....	22
<b>Hardness conversion table</b> .....	24
Approximate conversion values compared with Vickers hardness of Steel ....	24
Approximate converted values compared with Rockwell hardness for Steel .....	26
<b>Commonly used fitting tolerances for bore dimensions</b> .....	28
<b>Commonly used fitting tolerances for axis dimensions</b> .....	30
<b>Metric coarse and fine screw threads, and reference pilot hole dimensions</b> .....	32
<b>Spot facing and Thread hole for Hexagon socket head cap screws</b> ....	33
<b>Shape and dimensions of keyway for parallel key</b> .....	34
<b>C-type retaining ring for shaft (reference)</b> .....	37
<b>C-type retaining ring for hole (reference)</b> .....	38
<b>E-type retaining ring (reference)</b> .....	39
<b>Explanation of material notation</b> .....	39

# 1. Fundamental dimensions for various sizes of Tooth profile

There are three types of formulas to calculate various sizes of Tooth profile.

## (1) Module $m$ (Unit: mm)

Reference pitch divided by  $\pi$  is module, which defines the size of tooth in metric gear. If value of Reference diameter  $d$ (mm) divided by Number of teeth  $z$  increases, tooth capacity increases proportionately.

$$\text{Module } m = \frac{\text{Reference diameter } d}{\text{Number of teeth } z} \quad (\text{mm}) \quad \text{Tip (Outside) diameter is defined as } d_a,$$

calculation formula is  $m = \frac{d_a}{z + 2}$ . Refer to Fig. 1-1 for a full-scale drawing.

## (2) Diametral pitch $P$ or $DP$

Diametral pitch is size of tooth expressed in teeth per inch of pitch diameter. Formula of calculation is given as Number of teeth  $z$  divided by Reference diameter  $d$  (inch). Capacity of tooth profile increases and decreases inversely proportional to the numerical sum.

$$DP = \frac{\text{Number of teeth } z}{\text{Reference diameter } d \text{ (inch)}} \quad (\text{An absolute number}) \quad \text{Tip (Outside) diameter defined as } d_a,$$

$$\text{Calculation formula of } DP = \frac{z + 2}{d_a \text{ (in)}}$$

There is a relationship between module and Diametral pitch. (Comparison between module and Diametral pitch)

$$m = \frac{25.4}{DP} \quad (\text{mm}) \quad DP = \frac{25.4}{m}$$

## (3) Circular pitch $CP$

This is length of centre distance between adjacent teeth divided by arc circle of pitch circle. Calculated by circumference of pitch circle divided by number of teeth.

$$CP = \frac{\text{Circumference of Pitch circle } (\pi \times d)}{\text{Number of teeth } z} \quad (\text{mm})$$

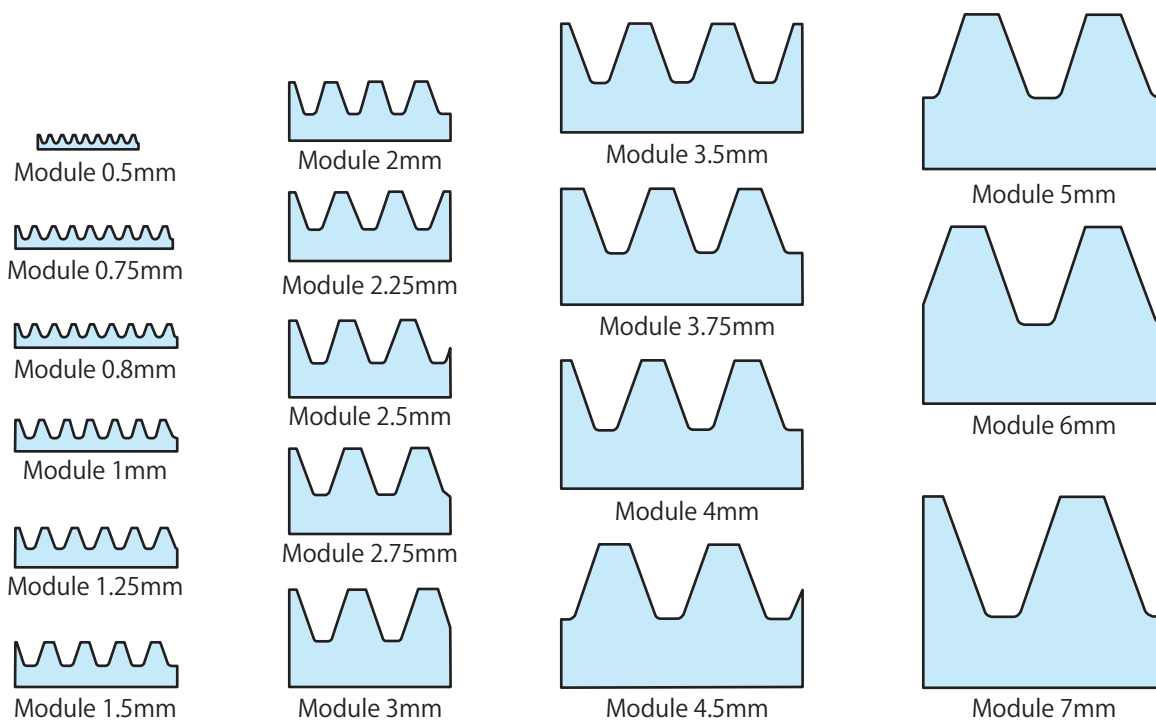

Fig. 1-1 Full-scale drawing of module

Note that  $\pi$  is ratio of the circumference of a circle to its diameter as  $\pi=3.14159 \dots$

Where Tip(outside) diameter  $d_a$ , calculation of  $CP = \frac{\pi \times d_a}{z + 2}$  (mm)

The 3 categories for size of Tooth profile mentioned above are widely used. In particular, Circular pitch CP is used to control traveling distance and positioning.

The standardization of module is shown by the following classification. Introduced in Japanese Industrial Standards

**JIS B 1701-2:** 1999 Cylindrical gear- Involute tooth profile and Article 2-Module and Appendix of the same standard (stipulation). Also shown below is classification not stipulated for Involute tooth profile cylindrical gear below module 1 in **ISO 54**.

**Table 1-1. Standard value for module of Cylindrical gear.**

Unit : mm

I		II		I		II		I		II	
0.1			1		1.125	6	5.5	25			28
	0.15			1.25			(6.5)	32			
0.2		0.25			1.375	8	7	40			36
		0.35		1.5			9	50			45
0.3			2		1.75	10					
	0.4			2.25			11				
0.4		0.45			2.25	12					
		0.55		2.5			14				
0.5			3		2.75	16					
	0.6			3.5			18				
		0.7			3.5	20					
0.6			4		4.5						
	0.75						22				
0.8		0.9		5							

It is advisable to select column-I of module (priority selection) as far as possible.

It is not advisable to select the module 6.5 as seen in column-II.

The standardization of module for Bevel gear is shown by the following classification. Introduced in **JIS B 1706-2:** 1999 Straight bevel gear- Article 2-Module and Diametral pitch and Appendix of the same standard (stipulation). Also shown below is classification not stipulated for Straight bevel gear below module 1 in **ISO 678**. However the Diametral pitch is omitted here.

**Table 1-2. Standard value for module of straight bevel gear.**

Unit : mm

I		II		I		II		I		II	
0.3			1		1.125	4					3.5
	0.35			1.25			1.375	5			4.5
0.4		0.45			1.5		1.75	6			5.5
		0.55		2			1.75				(6.5)
0.5			2		2.25			8			7
	0.6			2.5			2.75				9
		0.7						10			
0.6			3								
	0.75										
0.8		0.9									

It is advisable to select column-I of module (priority selection) as far as possible.

It is not advisable to select the module 6.5 as seen in column-II.

**Table 1-3. Comparison tables between module and Diametral pitch.**

Unit : mm

Module	9	8.467	8	7.257	7	6.35	6	5.08	5	4.233	4
Diametral pitch	2.822	3	3.175	3.5	3.629	4	4.233	5	5.08	6	6.35
Tooth depth	20.25	19.05	18.00	16.33	15.75	14.29	13.50	11.43	11.25	9.52	9.00
Pitch	28.27	26.60	25.13	22.80	21.99	19.95	18.85	15.96	15.71	13.30	12.57

Module	3.629	3.5	3.175	3	2.822	2.54	2.5	2.309	2.25	2.117	2
Diametral pitch	7	7.257	8	8.47	9	10	10.16	11	11.289	12	12.70
Tooth depth	8.17	7.88	7.14	6.75	6.35	5.72	5.63	5.20	5.06	4.76	4.50
Pitch	11.40	11.00	9.98	9.43	8.87	7.98	7.85	7.25	7.07	6.65	6.28

Module	1.814	1.75	1.588	1.5	1.411	1.27	1.25	1	0.8	0.75	0.5
Diametral pitch	14	14.514	16	16.933	18	20	20.32	25.4	31.75	33.867	50.8
Tooth depth	4.08	3.94	3.57	3.38	3.17	2.86	2.81	2.25	1.80	1.69	1.13
Pitch	5.70	5.50	4.99	4.71	4.43	3.99	3.93	3.14	2.51	2.36	1.57

Note that Tooth depth is calculated with Bottom clearance as  $C = 0.25 \times \text{module}$  (Unit: mm)

## 2. Advice on gear assembly

When assembling the gear pair, please note the following recommended points.

### (1) Beware of gear with scratches and rust, handle gear with care.

Small scratch marks may cause noise.

### (2) Measure the backlash.

Backlash regardless big or small causes noise. It is necessary to maintain proper backlash. If not, it is necessary to adjust centre distance. For details on KG-Backlash, please refer to Information page for each products.

### (3) Confirm tooth bearing.

Noise and oscillation is caused by poor tooth contact. Poor tooth bearing also harms the durability of the gear. Please refer to section 6 in References for more on tooth contact.

### (4) Use suitable type of lubricating oil in proper amounts.

Refer to section 8 in References for suitable type of lubricating oil in proper amounts.

### (5) Perform warm up and test run.

#### Importance of worm gear test run

We recommend that warm up and test run be performed before actual operations in order to improve hardness and strength of tooth flank.

(When applying Heat treatment to pinion only) Especially for Worm gear pair, warm up and test run is recommended to improve area of tooth bearing and surface strength.

Tooth profile for Worm gear pair has complicated curved surface compared with other gears making it difficult to fabricate Worm gear pair with improved accuracy. There are limitations to surface roughness when processed with lath only.

It is necessary to perform warm up and test run for Worm gear pair. Do not apply full load or close to full load to Worm gear pair or scuffing will occur easily.

For Warm up and Test run, gives improved evenness of tooth flank and increased tooth contact area (per square measure), which reduces the load (per square measure). It will also improve wear resistance against work hardening of tooth flank.

Therefore it provides a longer lifespan for the gear and reduces the noise level and oscillation.

#### How to worm gear test run

Method of Warm up and Test run. Firstly check the tooth contact while applying empty load and then gradually increase load to the gear.

We recommend changing all the lubricating oil after warm up and test run. Subsequently we recommend that the lubricating oil be changed every 6 months or 25,000 hours whichever ever comes first.

### (6) In addition, take note of dynamic balance and assembling method as recommended.

Please make final adjustments according to the actual operation status.

### 3. Centre distance for Spur and Helical gears

Gear assembly with accurate working centre distance is recommended for Spur and Helical gears. Fig. 3-1 shows an extract from the Allowable deviations of Centre distance for Spur and Helical gears as defined in JGMA 1101-1 (2000 Japan Gear Manufacturing Association).

#### Allowable tolerance for Centre distance

##### (1) Accuracy standard for Spur and Helical gears

Table 3-1 shows Allowable deviation of Centre distance for classes N3 to N12 gears of JIS B 1702-1 and JIS B 1702-2 (covers only ground and hobbing gears)

##### (2) Centre distance: Shortest distance from centre of axes of Parallel spur gear pair or gear pair with Non-parallel and Non-intersecting axes.

For example,

###### 1. Case of spur gear

Module is 0.5, Number of teeth is 20 : Half of reference diameter is 5

Module is 0.5, Number of teeth is 25 : Half of reference diameter is 6.25

Center distance above is 11.25mm

###### 2. Case of Helical gear (Normal module), Refer to the product page for reference diameter of the standard product.

Module is 1.5, Number of teeth is 13 : Half of reference diameter is 13.79

Module is 1.5, Number of teeth is 26 : Half of reference diameter is 27.575

Center distance above is 41.365mm

Table 3-1. Allowable tolerances of Centre distance for the gear

\*The above chart uses  $\pm$  symbol. It is recommended to use positive side tolerances for External gear pair and negative side tolerance for Internal gear pair.

Unit:  $\mu\text{m}$

System of accuracy a = Centre distance (mm)	N3, N4	N5, N6	N7, N8	N9, N10	N11, N12
$5.0 < a \leq 20.0$	$\pm 6$	$\pm 10$	$\pm 16$	$\pm 26$	$\pm 65$
$20.0 < a \leq 50.0$	$\pm 8$	$\pm 12$	$\pm 20$	$\pm 31$	$\pm 80$
$50.0 < a \leq 125.0$	$\pm 12$	$\pm 20$	$\pm 32$	$\pm 50$	$\pm 125$
$125.0 < a \leq 280.0$	$\pm 16$	$\pm 26$	$\pm 40$	$\pm 65$	$\pm 160$
$280.0 < a \leq 560.0$	$\pm 22$	$\pm 35$	$\pm 55$	$\pm 88$	$\pm 220$
$560.0 < a \leq 1,000.0$	$\pm 28$	$\pm 45$	$\pm 70$	$\pm 115$	$\pm 280$
$1,000.0 < a \leq 1,600.0$	$\pm 39$	$\pm 62$	$\pm 98$	$\pm 155$	$\pm 390$
$1,600.0 < a \leq 2,500.0$	$\pm 55$	$\pm 88$	$\pm 140$	$\pm 220$	$\pm 550$
$2,500.0 < a \leq 4,000.0$	$\pm 84$	$\pm 130$	$\pm 205$	$\pm 330$	$\pm 825$

### 4. Parallelism of axes for Spur and Helical gears

Extract from JGMA1102 (2000) is as follows.

**0. Preface:** This standard stipulates Allowable value of parallel accuracy for Spur and Helical gears.

Basically, these standards are consistent with recommended values from ISO/TR10064-3 (1996).

#### (1) Application range

This standard stipulates the parallel accuracy for steel-made Involute spur and helical gears. Therefore gears covered by this standard are simply called Gear.

- 1) Normal module: 0.5 to 70.0 (mm)
- 2) Reference diameter: 5.0 to 10,000.0 (mm)
- 3) Facewidth: From 4.0 to 1,000.0 (mm)

Remark 1. Double helical gear axis is also covered.

Remark 2. The above mentioned Standard is quoted from:

ISO/TR 10064-3 (1996) Cylindrical gears- Code of inspection practice- Part 3

JIS B 0102 (1999) International gear notation - Symbols for geometrical data

JIS B 1702-1 (1998) Cylindrical gears- ISO System of accuracy Classification-Article 1:

Definition and allowable values of deviations relevant to corresponding flanks of the gear teeth.

ISO/TR 10064-3 (1996) Cylindrical gears- Code of Inspection Practice- Part 3

## (2) Definition of terms

Definition for this standard is from JIS B 0102 (1999) (Terms of Tooth Flank-Geometric Definition) and following details.

- 1) **Parallel accuracy of axis:** Composes of accuracy of parallel deviation and Non-parallel and Non-intersection deviations.
  - 2) **Parallel deviation of axis:** Distance between C and O<sup>(1)</sup> (Refer to Fig. 4-1) where both ends of measurement distance L on the a-axis on one side of the gear are points A and B; and Flat face H is surface to include one of the points A and one of shaft centre b (b-axis); and flat face V is surface through point A and parallel to b and perpendicular to flat face H, and orthogonal projection of point B to H is C.
- Note(1): Point O is base of tolerance among perpendicular flat face S, V, H and B.
- 3) Refer to Fig.4-1, **deviation for Non-parallel and Non-intersecting axes:** Distance between points O and D where D is orthogonal projection of point B to V, referring to above (2).

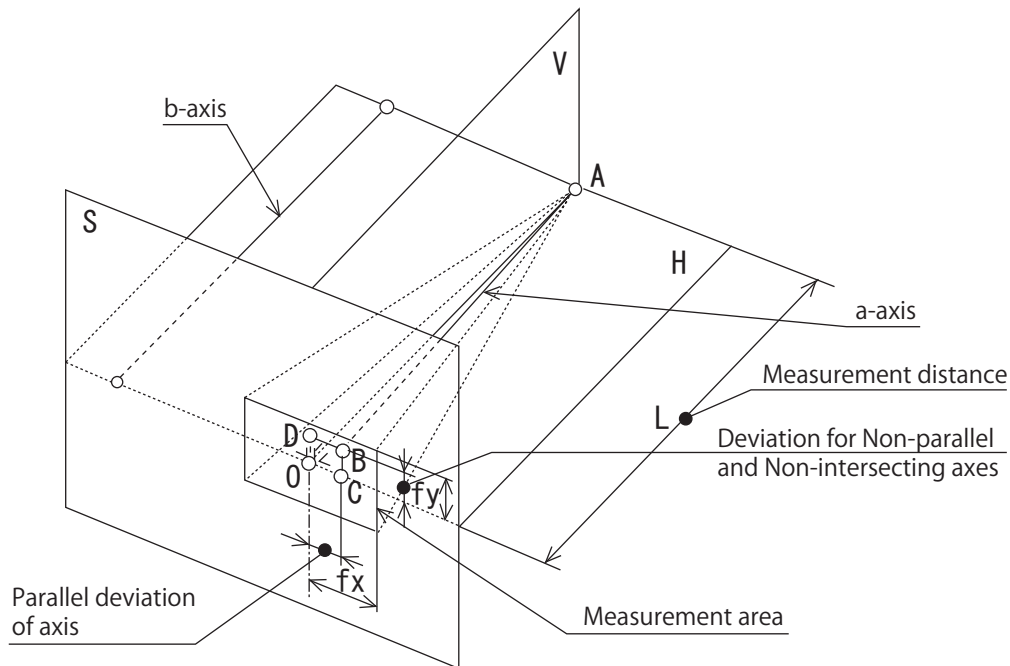

Fig. 4-1 Deviations for Parallel axis,  
Non-parallel and Non-intersecting axes.

## (3) Allowable value

Allowable value for parallel accuracy of gear axis is met with System of accuracy N10 to N12 in JIS B1702-1 (1998) as follows,

- 1) Allowable value of parallel deviation for axis  $f_x$   
Calculating  $f_x$  for measuring span  $L$  of gear axis is as follows,

$$f_x = \frac{L}{b} f_x'$$

Hereby,  $L$  : Measuring span (mm)

$b$  : Facewidth (mm), choose smaller dimension of Facewidth (mm) between pinion and gear.

$f_x'$  : Refer to Table 1 ( $\mu\text{m}$ )

2) Allowable value of deviation for Axes of Non-parallel and Non-intersecting  $f_y$ :

Calculation  $f_y$  for measuring span L of gear axis is as follows,

$$f_y = \frac{L}{b} f_y'$$

Hereby,  $L$  : Measuring span (mm)

$b$  : Facewidth (mm), choose smaller dimension of Facewidth (mm) between pinion and gear.

$f_y'$  : Refer to Table 2 ( $\mu\text{m}$ )

Remark

Depending on purpose of usage and System of accuracy class, which is different from the gear, Allowable value of deviation of parallelism accuracy of axis can be used.

Table 4-1. Allowable values of parallel deviations  $f_x'$  for axis per Facewidth

Unit:  $\mu\text{m}$

Reference diameter d (mm)	Facewidth b (mm)	System of Accuracy												
		N0	N1	N2	N3	N4	N5	N6	N7	N8	N9	N10	N11	N12
$5 \leq d \leq 20$	$4 \leq b \leq 10$	1.1	1.5	2.2	3.1	4.3	6.0	8.5	12	17	24	35	49	69
	$10 < b \leq 20$	1.2	1.7	2.4	3.4	4.9	7.0	9.5	14	19	28	39	55	78
	$20 < b \leq 40$	1.4	2.0	2.8	3.9	5.5	8.0	11	16	22	31	45	63	89
$20 < d \leq 50$	$4 \leq b \leq 10$	1.1	1.6	2.2	3.2	4.5	6.5	9.0	13	18	25	36	51	72
	$10 < b \leq 20$	1.3	1.8	2.5	3.6	5.0	7.0	10	14	20	29	40	57	81
	$20 < b \leq 40$	1.4	2.0	2.9	4.1	5.5	8.0	11	16	23	32	46	65	92
$50 < d \leq 125$	$4 \leq b \leq 10$	1.2	1.7	2.4	3.3	4.7	6.5	9.5	13	19	27	38	53	76
	$10 < b \leq 20$	1.3	1.9	2.6	3.7	5.5	7.5	11	15	21	30	42	60	84
	$20 < b \leq 40$	1.5	2.1	3.0	4.2	6.0	8.5	12	17	24	34	48	68	95
	$40 < b \leq 80$	1.7	2.5	3.5	4.9	7.0	10	14	20	28	39	56	79	111
$125 < d \leq 280$	$4 \leq b \leq 10$	1.3	1.8	2.5	3.6	5.0	7.0	10	14	20	29	40	57	81
	$10 < b \leq 20$	1.4	2.0	2.8	4.0	5.5	8.0	11	16	22	32	45	63	90
	$20 < b \leq 40$	1.6	2.2	3.2	4.5	6.5	9.0	13	18	25	36	50	71	101
	$40 < b \leq 80$	1.8	2.6	3.6	5.0	7.5	10	15	21	29	41	58	82	117
$280 < d \leq 560$	$10 < b \leq 20$	1.5	2.1	3.0	4.3	6.0	8.5	12	17	24	34	48	68	97
	$20 < b \leq 40$	1.7	2.4	3.4	4.8	6.5	9.5	13	19	27	38	54	76	108
	$40 < b \leq 80$	1.9	2.7	3.9	5.5	7.5	11	15	22	31	44	62	87	124
	$80 < b \leq 160$	2.3	3.2	4.6	6.5	9.0	13	18	26	36	52	73	103	146

Table 4-2. Allowable values of Non-parallel and Non-intersecting deviations  $f_y'$  for axis per Facewidth

Unit:  $\mu\text{m}$

Reference diameter d (mm)	Facewidth b (mm)	System of Accuracy												
		N0	N1	N2	N3	N4	N5	N6	N7	N8	N9	N10	N11	N12
$5 \leq d \leq 20$	$4 \leq b \leq 10$	0.5	0.8	1.1	1.5	2.2	3.1	4.3	6.0	8.5	12	17	24	35
	$10 < b \leq 20$	0.6	0.9	1.2	1.7	2.4	3.4	4.9	7.0	9.5	14	19	28	39
	$20 < b \leq 40$	0.7	1.0	1.4	2.0	2.8	3.9	5.5	8.0	11	16	22	31	45
$20 < d \leq 50$	$4 \leq b \leq 10$	0.6	0.8	1.1	1.6	2.2	3.2	4.5	6.5	9.0	13	18	25	36
	$10 < b \leq 20$	0.6	0.9	1.3	1.8	2.5	3.6	5.0	7.0	10	14	20	29	40
	$20 < b \leq 40$	0.7	1.0	1.4	2.0	2.9	4.1	5.5	8.0	11	16	23	32	46
$50 < d \leq r125$	$4 \leq b \leq 10$	0.6	0.8	1.2	1.7	2.4	3.3	4.7	6.5	9.5	13	19	27	38
	$10 < b \leq 20$	0.7	0.9	1.3	1.9	2.6	3.7	5.5	7.5	11	15	21	30	42
	$20 < b \leq 40$	0.7	1.1	1.5	2.1	3.0	4.2	6.0	8.5	12	17	24	34	48
	$40 < b \leq 80$	0.9	1.2	1.7	2.5	3.5	4.9	7.0	10	14	20	28	39	56
$125 < d \leq 280$	$4 \leq b \leq 10$	0.6	0.9	1.3	1.8	2.5	3.5	5.0	7.0	10	14	20	29	40
	$10 < b \leq 20$	0.7	1.0	1.4	2.0	2.8	4.0	5.5	8.0	11	16	22	32	45
	$20 < b \leq 40$	0.8	1.1	1.6	2.2	3.2	4.5	6.5	9.0	13	18	25	36	50
	$40 < b \leq 80$	0.9	1.3	1.8	2.6	3.6	5.0	7.5	10	15	21	29	41	58
$280 < d \leq 560$	$10 < b \leq 20$	0.8	1.1	1.5	2.1	3.0	4.3	6.0	8.5	12	17	24	34	48
	$20 < b \leq 40$	0.8	1.2	1.7	2.4	3.4	4.8	6.5	9.5	13	19	27	38	54
	$40 < b \leq 80$	1.0	1.4	1.9	2.7	3.9	5.5	7.5	11	15	22	31	44	62

## 5. Measurement of the backlash

### (1) Backlash of Bevel gear pair

To Measure the backlash for Bevel gear pair, there are two (2) types of measurements. Circumferential backlash  $j_t$  and normal backlash  $j_n$ , which is the same for Spur and Helical gears.

Fix the pinion and put an indicator to outer gear to measure.

Normal pressure angle  $\alpha_n$  and centre (mean) gear tooth of helix angle  $\beta_m$  of Spiral bevel gear have the following relationship between  $j_t$  and  $j_n$ .

$$j_n = j_t \cos \alpha_n \cos \beta_m \quad j_t = j_n / \cos \alpha_n \cos \beta_m$$

(The above calculation formula is for Spiral bevel gear. For Straight bevel gear, it is cosine  $\beta_m = 1$ )

Circumferential backlash for Bevel gear pair is stipulated in JIS B 1705.

In addition to this, there is another method to assemble the Bevel gear with a designated Locating distance. Fix a gear and move the Pinion in axis direction. Measure the amount of movement with an indicator.

Bevel gear has the following relationship between Circumferential backlash  $j_t$  and Locating direction  $j_x$ .

$$j_x = j_t / 2 \tan \alpha_n \sin \delta_i \quad \text{Straight bevel gear}$$

$$j_x = j_t / 2 \tan d_i \sin \delta_i \quad \text{Spiral bevel gear}$$

Hereby

$j_t$ : Circumferential backlash at Transverse plane

$$j_t = j_n / \cos \alpha_t$$

$\alpha_t$ : Transverse pressure angle  $\alpha_t = \tan^{-1}(\tan \alpha_n / \cos \beta)$

For example, Straight bevel gear with Pressure angle  $20^\circ$  and gear ratio 1:1. Assuming that Circumferential backlash  $j_t$  is 1.0mm therefore backlash of Locating direction is 1.94mm. Which means it can measure minute backlash to about twice the accuracy.

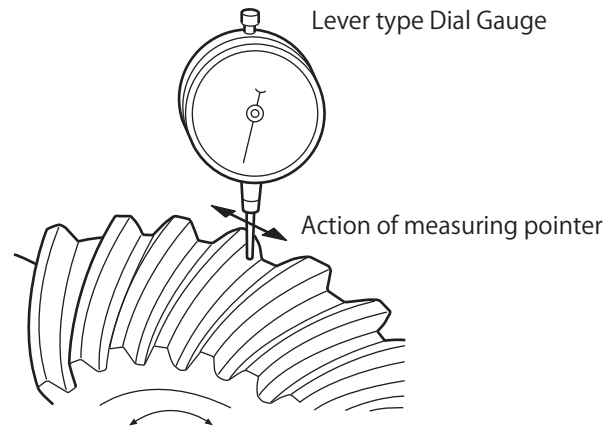

Fig. 5-1 Measurement method of backlash for the Bevel gear (Circumference direction)

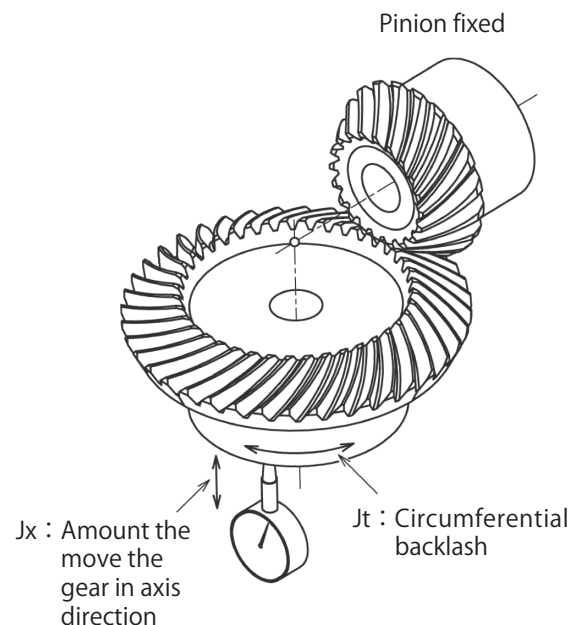
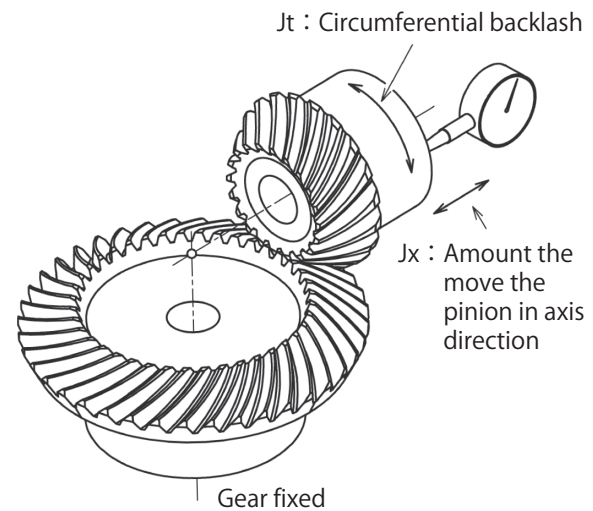

Fig.5-2 Move the pinion in axis direction to measure the backlash.



## (2) Backlash of Worm gear pair

Generally the Worm gear is fixed and indicator is placed to flank of Worm wheel for backlash measurement. This is the same method for both Spur and Helical gears pair.

Shown in backlash value for each product page, value for KG-Worm gear pair with assembled designated centre distance. Due to undefined backlash for Worm gear in JIS currently.

When using worm gear pair for accurate locating and positioning, it is necessary to keep backlash to a minimum. Providing large backlash for power transmission is recommend due to expansion caused by generation of heat. Even though the backlash may be larger, performance of worm gear pair will almost be the same.

Racing angle of Worm gear caused by backlash become a crucial problem occasionally.

Below is the explanation of the calculation formula for racing angle of Worm gear instead of backlash of Worm wheel.

Place an indicator to flank of Worm Wheel as show in Fig. 5-3 to measure circumferential backlash.

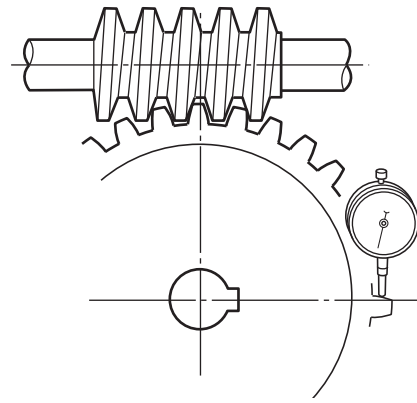

Fig. 5-3 Method of measurement for Worm gear pair (Circumference direction)

For example,

Module is 2.0,

Gear ratio 1 : 30,

Reference diameter of Worm gear is 31.0 mm,

Lead angle of Worm gear is  $3^{\circ}42''$  ,

Lead of Worm gear is 6.2963,

Measurement amount of Circumferential backlash is 0.2 mm.

Calculation formula is as follows.

(Lead) :  $(360^{\circ}) = (\text{Measured circumferential backlash})$   
: (Racing angle of Worm gear) therefore,

$$\text{Racing angle of Worm gear} = \frac{360^{\circ} \times \text{Circumferential backlash}}{\text{Lead}} = 360^{\circ} \times 0.2 / 6.2963$$

$$= 11^{\circ}27'$$

Worm gear provides the racing of  $11^{\circ}27'$  .

(Lead of Worm gear : It is the distance of a point on the flank as it moves forward in axis direction when the Worm gear turns one revolution.)

## 6. Tooth bearings

Regardless of how accurate the gear itself may be, poor tooth bearing not only causes oscillation and noise but also have bad effect on gear's life span.

Refer to Fig. 6-1. Extracted **Tooth bearing on gear from JIS B 1741-1977 (old)**

JIS B1741 (old) 「Tooth bearing on Gear」 stipulates percentage of tooth bearing mark as follows.

As for Tooth trace direction, it is percentage (%) of mean value  $b_c$  of Length of tooth bearing for Effective length of trace -  $b'$ . As for Tooth depth direction, it is percentage (%) of mean value  $l_c$  of tooth bearing width for Working depth-  $h'$ .

Note\* For edge of gear tooth with chamfering, Effective length of trace is after deducting chamfered area. For different Effective lengths of Tooth trace between Pinion and Gear, take the shorter side.

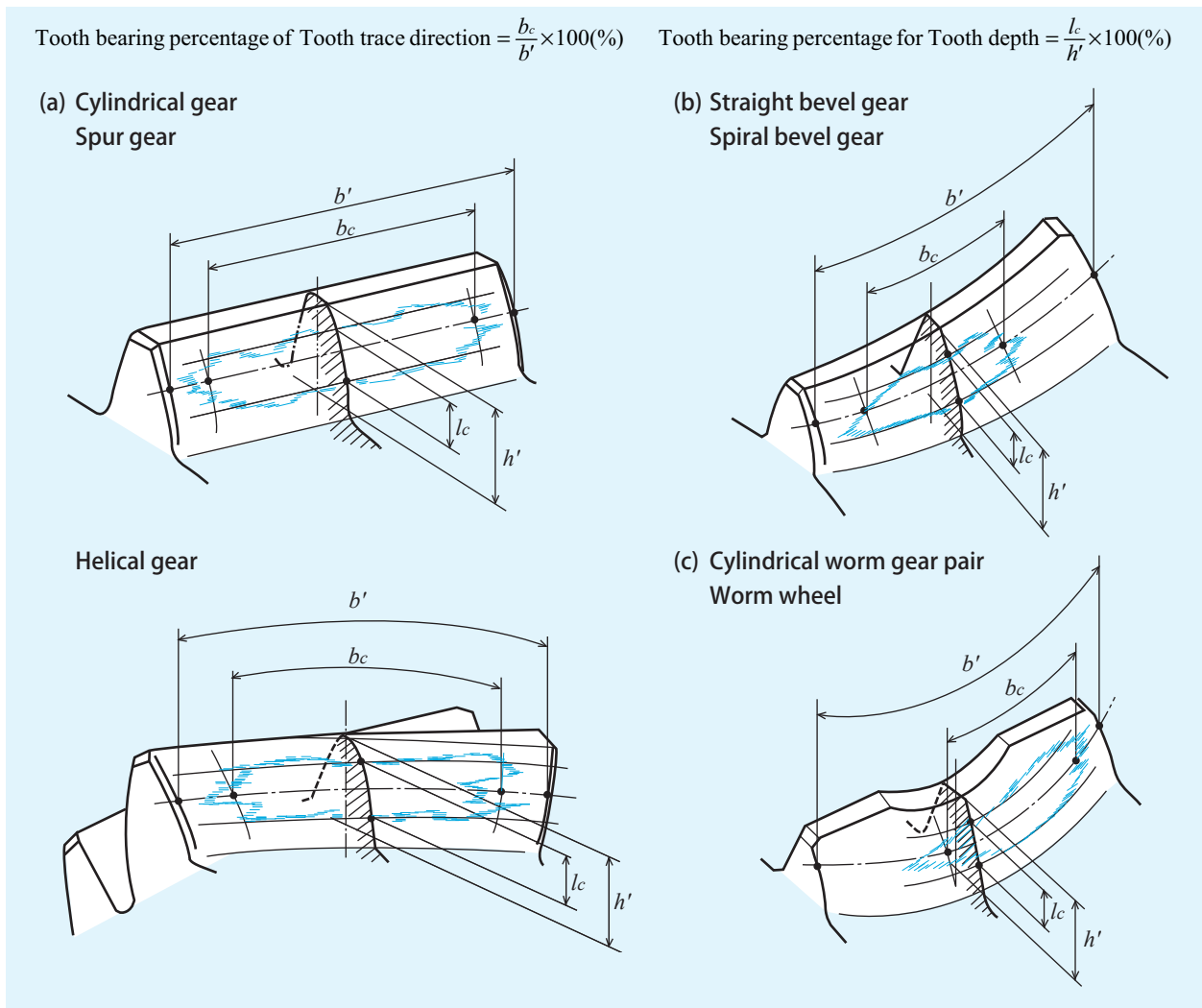

Fig. 6-1 Tooth bearing

Refer to Fig. 6-2 for Bevel gear with Crowning and empty load. It is desirable that centre of tooth bearing in Tooth trace direction is about 60% of Length of tooth trace from heel.

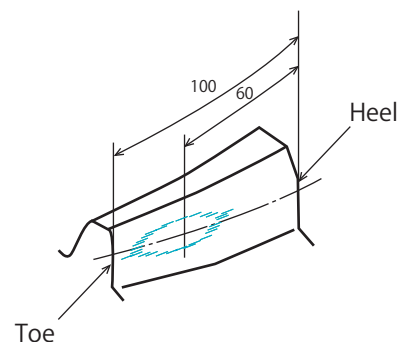

Fig. 6-2 Tooth bearing for Bevel gear with Crowning.

Percentage of tooth bearing for Worm gear pair is for Worm wheel engaged with Worm gear. In general, Tooth bearing to inflow side of flank of Worm wheel is not desirable. It is desirable for Tooth bearing centre in Tooth trace direction to be biased towards outflow side to make clearance at inflow side. (Refer to Fig. 6-3)

Fig. 6-3 Tooth bearing for Worm wheel

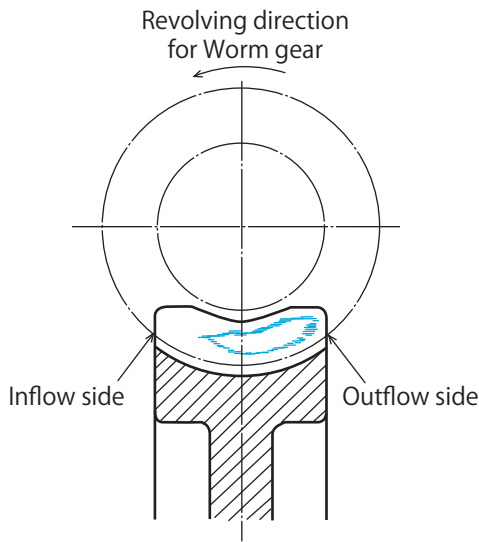

Fig. 6-4 Inflow clearance for Worm gear pair

{A few problems of lubricating oil for Worm gear pair and research work for machine. Volume 8, No. 4 (1956) written by Dr. Waguri and Dr. Ueno from Yokendo Co. Ltd.}

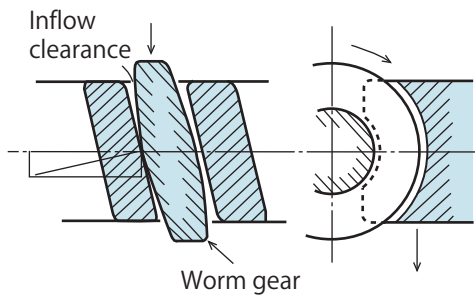

Fig. 6-5 Line of contact for Worm gear pair (2 number of threads) and Tooth bearing for standard Worm gear. Quoted literature is the same as Fig. 6-4.

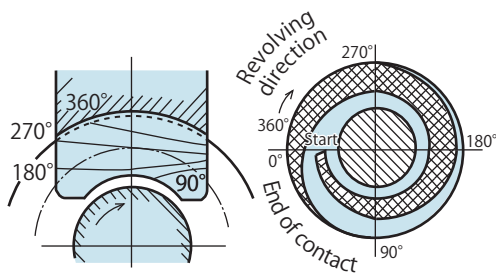

Fig. 6-6 Engagement for Bevel gear with Crowning {Gleason Company, INSTALLATION OF BEVEL GEARS (1965)}

Coniflex® Bevel Gear  
(Straight bevel gear with Crowning)  
® mark is Gleason Works trademark

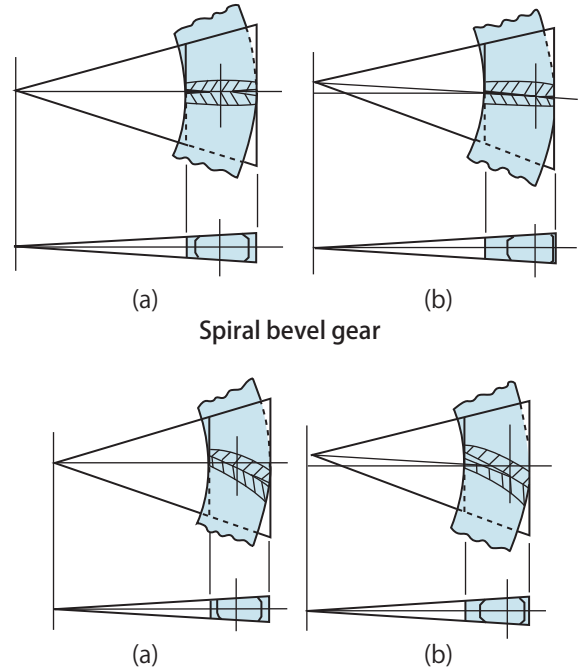
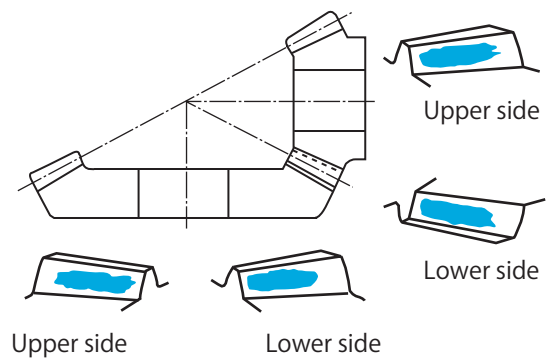
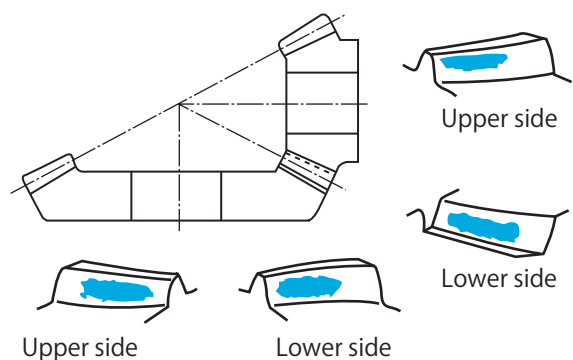

Fig. (a) shows proper assembly method, (b) is assembled off centre from location of Top cone. Please observe the difference in position for Tooth bearing.

Fig.6-7 Ideal tooth bearing for Bevel gear



Spiral bevel gear  
(Pinion: Shape of teeth is left hand)



Tables 6.1 to 6.4 represents the recommended tooth bearing categories according to gear accuracy grades.

**Table 6-1. Percentage of tooth bearing for Cylindrical gear (Spur and Helical gears)**

Class	Percentage of tooth bearing	
	Tooth trace direction	Tooth depth direction
A	Above 70% of Effective length of Tooth trace	Above 40% of Effective length of Tooth profile
B	Above 50% of Effective length of Tooth trace	Above 30% of Effective length of Tooth profile
C	Above 35% of Effective length of Tooth trace	Above 20% of Effective length of Tooth profile

**Table 6-2. Percentage of tooth bearing for Worm gear pair (Worm wheel)**

Class	Percentage of tooth bearing	
	Tooth trace direction	Tooth depth direction
A	Above 50% of Effective length of Tooth trace	Above 40% of Effective length of Tooth profile
B	Above 35% of Effective length of Tooth trace	Above 30% of Effective length of Tooth profile
C	Above 20% of Effective length of Tooth trace	Above 20% of Effective length of Tooth profile

**Table 6-3. Percentage of tooth bearing for Bevel gear**

Class	Percentage of tooth bearing	
	Tooth trace direction	Tooth depth direction
A	Above 50% of effective length of Tooth trace	Above 40% of Effective length of Tooth profile
B	Above 35% of Effective length of Tooth trace	Above 30% of Effective length of Tooth profile
C	Above 25% of Effective length of Tooth trace	Above 20% of Effective length of Tooth profile

**Table 6-4. Table for Tooth bearing classification and System of accuracy**

Class	System of accuracy for Cylindrical gear	System of accuracy class for Bevel gear
	JIS B 1702-1960 (old)	JIS B 1704-1973
A	1, 2	1, 2
B	3, 4	3, 4
C	5, 6	5, 6

## 7. Gear efficiency

(Reference for gears only)

Types of gear		Efficiency of gear
Spur gear		97 - 99%
Helical gear		97 - 99%
Bevel gear		96 - 99%
Worm gear	Single thread	45 - 55% *
	Double thread	55 - 65% *

\*Above efficiency values are for KG STOCK GEARS only

## 8. Lubricating oil for Gears

### (1) Purpose of using lubricating oil

Purpose of using lubricating oil for longer life of gear is as follows,

- 1) Avoid metal contact (without oil film) to flank.
- 2) Reduce frictional heat from flank
- 3) Reduce vibration and noise.

In addition, better efficiency with less oscillation and noise can be expected.

Insufficient lubricating oil to flank can cause high oscillation and noise in a short time. Scuffing will occur with the increasing temperature, resulting in damage to the bearing. To prevent such problems, apply suitable lubricating oil to the gear is necessary. Proceed with proper method and amount to gear.

### (2) Method of lubricating oil

Classifications of lubricating oil to gears are as follows,

- 1) Grease lubricating method
- 2) Splash lubricating method (Oil bath or Splash lubrication)
- 3) Forced lubricating method

Selection of Method of lubricating oil can be by types of gears, Circumferential velocity, surface pressure (load applied to gear), finishing condition of flank, hardness of material and combination of materials. However, Circumferential velocity is usually used.

Table 8-1 indicates guide for selecting gear's lubricating method by circumferential velocity.

Table 8-1 (1) For Spur, Helical and Bevel gears

Lubrication method	Circumferential velocity (m/s)				
	0	5	10	15	20
Grease lubricating method	→				
Splash lubricating method	←→				
Forced lubricating method	←				

Table 8-1 (2) For Worm gear pair and Hypoid gears

Lubrication method	Circumferential velocity (m/s)				
	0	5	10	15	20
Grease lubricating method	→				
Splash lubricating method	←→				
Forced lubricating method	←				

Table 8-1. Guide for selecting gear lubricating method by circumferential velocity.

#### How to calculate Circumferential velocity

$$\text{Circumferential velocity (m/s)} = \frac{\pi \times \text{Reference diameter (mm)} \times \text{The number of revolution (min}^{-1}\text{)}}{1000 \times 60}$$

※Please be careful about the units of numerical values.

### (3) Proper level of lubricating oil

#### 1) Splash lubricating method (Oil bath or Splash lubricating)

Amount of lubricating oil for soaking each type of gear is different. The mixer resistance and windage are increased when large amount of lubricating oil are used for soaking the gear. Fig. 8-1 shows the proper level of lubricating oil for soaking the gear.

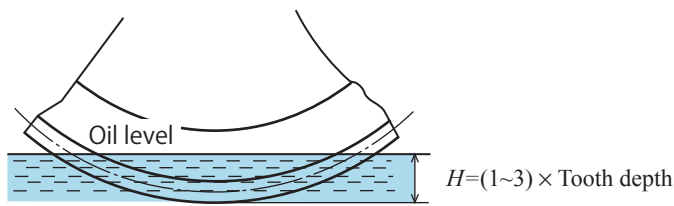

(a) Spur and Helical gears (Horizontal axis)

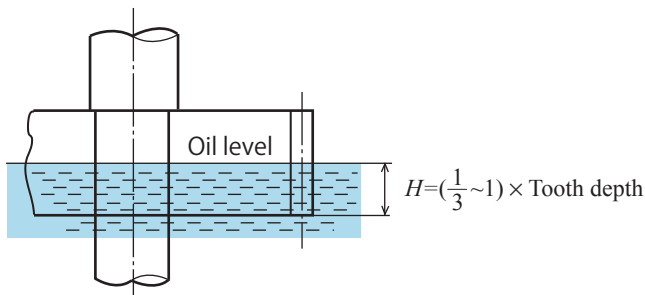

(b) Spur and Helical gears (Perpendicular axis)

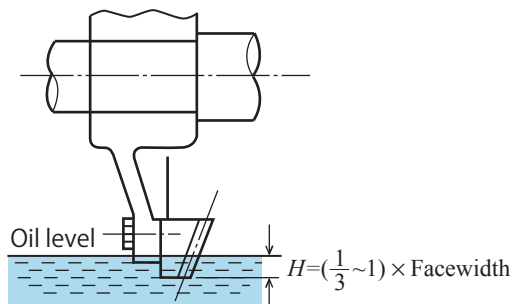

(c) Bevel and Hypoid gears

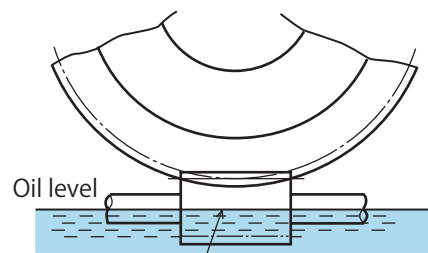

(d1) Worm gear pair (Lower position of Worm gear)

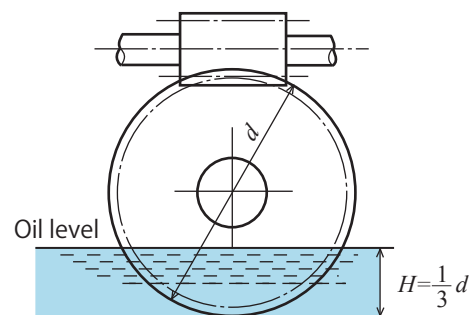

(d2) Worm gear pair (Upper position of Worm gear)

Fig. 8-1 Soaking level of gear in gearbox

#### 2) Forced lubricating method

##### Spraying oil:

In general, temperature of lubricating oil should not exceed 8°C when lubricating oil flows onto working area of gear. Criterion for facewidth per cm is 0.5 l/min for low speed and 1 l/min for high speed. Lubricating oil for high speed, use following empirical formula.

$$\text{Oil level (l/min)} = 0.6 + 2 \times 10^{-3} \cdot m v$$

Hereby

$m$  : Module (mm)

$v$  : Circumferential velocity (m/s) of Pitch circle

##### How to spray:

Spray before the starting area of gear engagement with lubricating oil perpendicular to flank. In rare instances for high speed, spray in the direction towards the end of the engagement.

To prevent temperature of oil from increasing, the collected oil should go through a cooling process using cooling equipment before being reused.

#### (4) Features of Polyacetal gear

Strength of plastic gear compared with metal gear excluding external factors is 1/6 to 1/9. However, it is necessary to take factors like temperature, humidity and others into considerations.

Table 8-2. Circumferential speed and Limitation of frictional speed

Lubrication	Without lubricating oil	Lubricating oil
Circumferential speed for Spur and Bevel gears m/s	6	12
Frictional speed for Worm gear pair m/s	1	2.5

Lowest usage temperature limitation -38°C

#### Backlash for plastic gear

Plastic material has extremely smaller thermal conductivity and larger thermal expansion factor compared with metals. Plastic gear pair has higher tendency to change dimension compared with metal gear. Therefore KG has intentionally fabricated wider backlash plastic gears as compared with metal gears.

#### (5) Combination of gear materials

The combination of materials for plastic gear pair, assuming combination between Polyacetal, metal material factor is 1.0. When combining two Polyacetals, material factor is 0.75. Therefore gear strength for Polyacetal gear pair becomes 75%.

We believe that engagement between Polyacetal and metal gears are best combination.

However, note that maximum surface roughness Ra1.6

at flank for metal gear is advised to prevent wear for plastic gears.

## 9. Cause and solution for noise and oscillation

During operation of machine, make sure that gearing sound can be heard. 500 to 5,000 Hz is comfortable sound frequency for humans. Even if it is not loud, depending on the frequency component or the environment where the gears are used, such sound may feel unpleasant. Occurrence of noise is often blamed on the gear. However, noise problems are not solely from gear but may also include causes from designing error to lubrication. Refer to Fig. 9-1 for cause and solution.

Refer to Fig. 1 to reduce the noise level by following solutions.

- 1) Improve the accuracies of gear and gear assembly. → (Preventing at source)
- 2) For gear, axis and gearbox, provide suitable material and design to reduce noise. → (Reduce the cause of noise level)  
(avoid resonance and quick attenuation)
- 3) Provide a sealed type of gearbox to shut in the noise. → (Shield and cover)

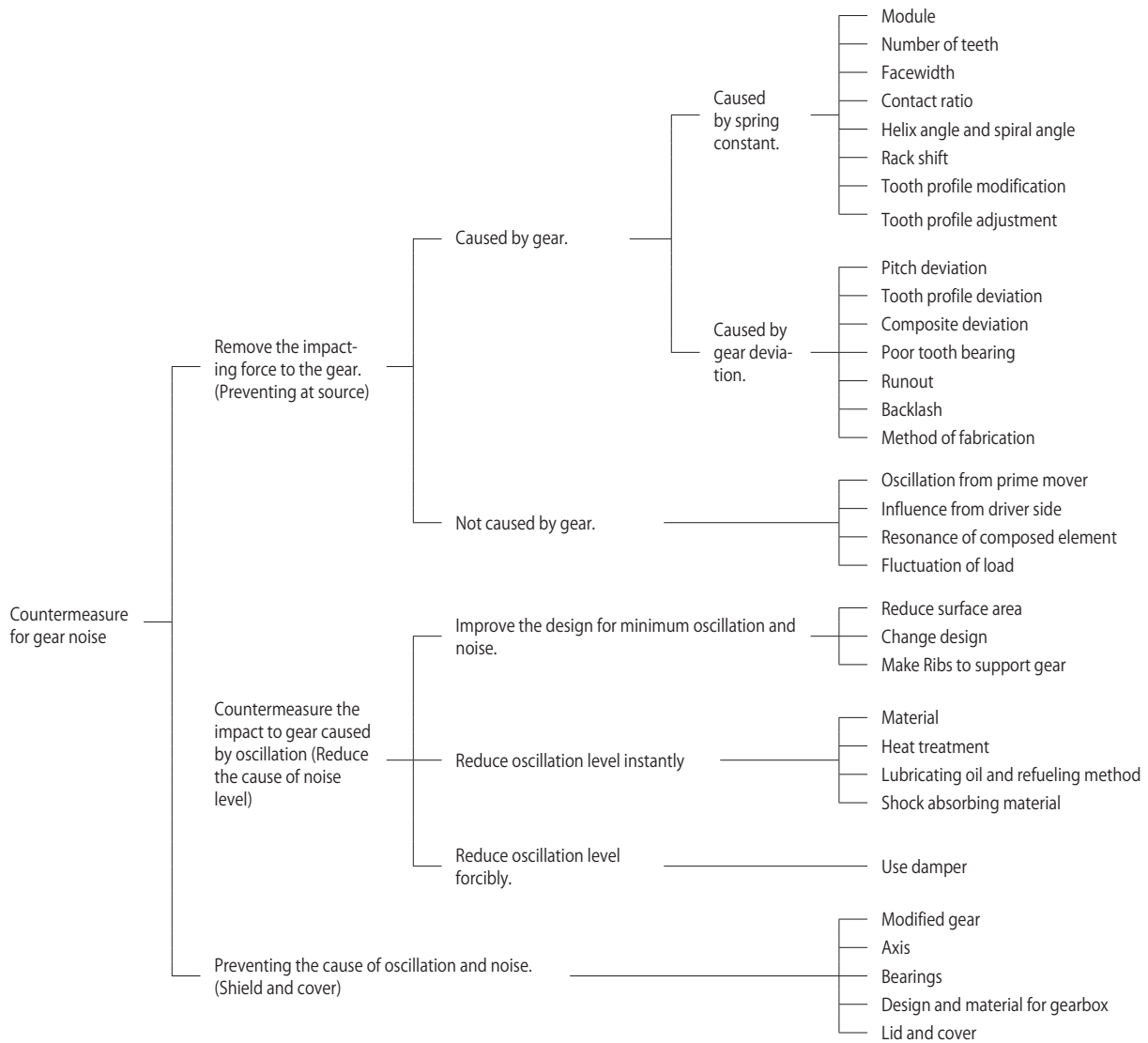

Fig. 9-1 Cause and solution for gear noise



## 10. The vocabulary of gear and gear terms.

### We have been adopting the symbol of JIS.

The Vocabulary of each dimension for the gear's drawing in various usages includes many different fields. KG has been adopting the symbols as there is reference literature of JIS standard and gear.

### The Vocabulary of Gear and Gear terms.

With regard to the Vocabulary of gear for gear calculation, define JIS B 0121-1999(Gear vocabulary).

With regard to the Gear terms, define JIS B 0102(Gear terms)

#### The relative dimension of the Rectilinear and Circumference

Gear Terms	Vocabularies
center distance	$a$
when you call pitch	$P$
reference pitch	$P$
transverse pitch	$P_t$
normal pitch	$P_n$
axial pitch	$P_x$
base pitch	$P_b$
transverse base pitch	$P_{bt}$
normal base pitch	$P_{bn}$
tooth depth	$h$
addendum	$h_a$
dedendum	$h_f$
chordal addendum	$\bar{h}$
working tooth depth	$h'$
when you call tooth thickness	$s$
tooth thickness	$s$
base circle	$s_b$
chordal tooth thickness	$s$
sector span	$w$
spacewidth	$e$
bottom clearance	$c$
circumferential backlash	$j_i$
normal backlash	$j_n$
facewidth	$b$
effective facewidth	$b'$ or $b_w$
lead	$P_z$
length of path of contact	$g_a$
length of approach path	$g_f$
length of recess path	$g_\alpha$
overlap length	$g_\beta$
when you call diameter	$d$
reference diameter	$d$
intermeshing pitch diameter	$d'$ or $d_w$
tip diameter	$d_a$
base diameter	$d_b$
root diameter	$d_f$
when you call radius	$r$
reference radius	$r$
intermeshing pitch radius	$r'$ or $r_w$
tip radius	$r_a$
base radius	$r_b$
root radius	$r_f$
curvature radius	$\rho$
when you call cone distance	$R$
cone distance	$R_e$
mean cone distance	$R_m$
inner cone distance	$R_i$
back cone distance	$R_v$
locating distance	$A$

#### The Angulars

Gear Terms	Vocabularies
when you call pressure angle	$\alpha$
reference pressure angle	$\alpha$
intermeshing pressure angle	$\alpha'$ or $\alpha_w$
cutter pressure angle	$\alpha_o$
transverse pressure angle	$\alpha_t$
normal pressure angle	$\alpha_n$
axial pressure angle	$\alpha_x$
when you call helix angle	$\beta$
reference cylinder helix angle	$\beta$
tip cylinder helix angle	$\beta_a$
base cylinder helix angle	$\beta_b$
when you call lead angle	$\gamma$
reference cylinder lead angle	$\gamma$
tip cylinder lead angle	$\gamma_a$
base cylinder lead angle	$\gamma_b$
shaft angle	$\Sigma$
when you call angle	$\delta$
pitch angle	$\delta$
tip angle	$\delta_a$
root angle	$\delta_f$
addendum angle	$\theta_a$
dedendum angle	$\theta_f$
transverse angle of transmission	$\phi^\alpha$
overlap angle	$\phi^\beta$
total angle of transmission	$\phi^\gamma$
angle pitch of crown gear	$\tau$
involute $\alpha$	$\text{inv } \alpha$

#### The Number of teeth and Gear ratio

Gear Terms	Vocabularies
number of teeth	$z$
equivalent number of teeth	$z_v$
number of thread	$z_1$
gear ratio	$u$
transmission ratio	$i$
module	$m$
transverse module	$m_t$
normal module	$m_n$
axial module	$m_x$
contact ratio	$\varepsilon$
transverse contact ratio	$\varepsilon^\alpha$
overlap contact ratio	$\varepsilon^\beta$
total contact ratio	$\varepsilon^\gamma$
specific sliding	$\sigma$
angular velocity	$\omega$
linear velocity	$v$
revolution per minute	$n$
rack shift coefficient	$x$
center distance modification coefficient	$y$

# 11. Interpretation of Allowable capability torque table.

The Bending Strength, Surface Durability and Allowable Transfer Capability Torque of Worm Wheel are introduced by using JGMA (Japan Gear Manufacturers Association) formula except Poly Acetal material. This JGMA formula does not apply to every gear, or some is reference only. Therefore refer to the below classification of reference 11-1 for Kind of the gear and Module size.

Applicable range for JGMA formula (Reference 11-1)

Kind of Gears	JGMA standard	Range of Module	Pitch Diameter
Spur gear	JGMA401 – 01	1.5 ~ 25mm	Pitch diameter 25 ~ 3200mm
Helical gear	JGMA402 – 01		
Bevel gear	JGMA403 – 01	Outertransverse module 1.5 ~ 25mm	Below 1600mm of Outer pitch diameter 1600mm 以下
Spiral bevel gear	JGMA404 – 01		Below 1000mm of Outer pitch diameter 1000mm 以下
Worm gear pair	JGMA405 – 01	Metric axial module 1.0 ~ 25mm	Below 900mm Pitch diameter of Worm wheel 900mm 以下

## (1) Bending Strength and Surface Durability for Spur and Helical gears.

Descriptions	Material	S45C		<sup>(1)</sup> SUS304	<sup>(1)</sup> C3604B	Poly Acetal	
	SCM435	–	Induction hardening				
Calculation	Calculation for Bending strength of Spur and Helical gears as JGMA 401-01.					Louis formula	
	Calculation for Surface durability of Spur and Helical gears as JGMA 402-01.						
Matching gear	The same number of teeth and same material					–	
Stress of Allowable Bending : $\sigma F_{lim}$	36.5kgf/mm <sup>2</sup>	21.0kgf/mm <sup>2</sup>	25.0kgf/mm <sup>2</sup>	10.5kgf/mm <sup>2</sup>	4.2kgf/mm <sup>2</sup>	3.4kgf/mm <sup>2</sup>	
Stress of Allowable Hertz : $\sigma H_{lim}$	121kgf/mm <sup>2</sup>	–	106.5kgf/mm <sup>2</sup>	–	–	–	
The number of times of engagement between two gears during life span	Above 10 to the power of 7.					( $K_L=1.0$ )	–
Impact from motor side.	Flat load					–	
Impact from load	Average impact					( $K_o=1.25$ )	–
Lubricating system and Oil viscosity	Oil Lubrication. 100 cSt (50°C)					( $Z_L=1.0$ )	–
Method of supporting gear	Double supporting with plane symmetry to both bearing					–	
Safety Factor of Tooth Breakage : $S_F$	1.2					–	
Factor of safety at Surface strength : $S_H$	1.15					–	
Load direction	One-way direction					–	

Regarding the amount of allowable transfer capability, load direction is the reversible and the middle gear become 2/3 (including rack pinion). Surface Durability in Allowable transfer capability table that the formula does not apply to Idler gear or mid gear engaged with 2 gears.  
Note (1) Sub standard JGMA401-01 and JGMA402-01 equivalent to JGMA 6101-01 and JGMA6102-01.

The Amount of Allowable transfer torque [N.m] at the number of revolution per minute  $n=100$  [N.m] to each reference compare with Bending strength of Allowable transfer capability table (Range: Module 1.0 to 5.0 with ISO C45 carbon steel) in KG-catalogue.

## (2) Bending strength and Surface durability for Bevel gears.

Material	SCM435	SCM440	S45C		(2) SUS304
	Induction hardening	Ground tooth Induction hardening	—	Induction hardening	
Descriptions	Calculation for Bending strength of Bevel gears as JGMA 403-01.				
	Calculation for Surface durability of Bevel gears as JGMA 404-01.				
Matching gear	Nominative Matching gear.				
Stress of Allowable Bending : $\sigma F_{lim}$	31.0kgf/mm <sup>2</sup>	31.0kgf/mm <sup>2</sup>	19.0kgf/mm <sup>2</sup>	22.0kgf/mm <sup>2</sup>	10.5kgf/mm <sup>2</sup>
Stress of Allowable Hertz : $\sigma H_{lim}$	109.0kgf/mm <sup>2</sup>	115.0kgf/mm <sup>2</sup>	54.0kgf/mm <sup>2</sup>	85.0kgf/mm <sup>2</sup>	—
The number of times of engagement between two gears during life span	Above 10 to the power of 7.				( $K_L=1.0$ )
Impact from motor side.	Flat load				
Impact from load	Average impact				( $K_I=1.25$ )
Lubricating system and Oil viscosity	Oil Lubrication. 100 cSt (50°C)				( $Z_L=1.0$ )
Stiffness of gear shaft and gearbox.	Standard				
Supporting condition of the gear	Overhang condition				
			( $K_{\beta}=1.8$ )		
Coefficient of reliability of Tooth Breakage : $K_R$	1.2				
Coefficient of reliability at Surface strength : $C_R$	1.15				
Load direction	One-way direction				

Regarding the amount of allowable transfer capability, load direction is the reversible and the middle gear become 2/3.  
 Note (2) Sub standard JGMA403-01 and JGMA404-01 equivalent to JGMA 6101-01 and JGMA6102-01.

## (3) Surface durability of Cylindrical worm gear pair.

Material of Wheel	C3604B Brass	FC200 Cast iron	CAC702 Aluminum Bronze
Descriptions	Calculation for Surface strength of Cylindrical worm gear pair.		
Coefficient of Allowable Stress at Surface strength : $\sigma F_{lim}$	0.42	0.63	0.56
Effective life period	26,000 hours		
Oil Lubrication.	Provided extreme additive lubricant oil with proper viscosity.		( $Z_L=1.0$ )
Lubricating system	Oil bath Lubrication		( $Z_M=1.0$ )
Surface contact	This Surface contact is equivalent to classification A of JIS B1741 (Surface contact)		( $K_C=1.0$ )
Starting condition	Starting torque should below 200 % from rating torque and the number of starting time should less than 2 times.		( $K_S=1.0$ )
Impact from motor side.	Flat load		
Impact from load	Flat load		( $K_H=1.0$ )

Regarding the amount of allowable transfer capability, load direction is the reversible and the middle gear become 2/3.  
 Note (1) Sub standard JGMA403-01 and JGMA404-01 equivalent to JGMA 6101-01 and JGMA6102-01.

## 12. While examination of Bending strength from the Allowable transfer capability table, Surface strength check are necessary too.

**To calculate Allowable transfer torque of KG STOCK GEARS.  
To select KG-STOCK GEARS from usage condition of Spur gear.**

### **For example 1. To calculate Allowable transfer torque: T[N.m]**

(1) For example, calculating KG — STOCK GEAR S2S 40B-2016

- 1) Module M2.0      3) Face width 20mm
- 2) No. of teeth z=40      4) Bore 16mm

(2) Usage condition of Spur gear.

- 1) Gear ratio of Spur gear  $u=1:1$
- 2) The number of revolution  $n=100$  rpm
- 3) Providing conditions with usage of gear for strength calculation. Please refer to Calculation for Bending strength of Spur and Helical gears as JGMA401-01.
  - a) The gear is in gearbox with lubricant oil.
  - b) Bearing in gearbox should position on both sides. Bearings are plane symmetry.
  - c) Receiving load from a motor side is a flat load or less.
  - d) Receiving impact from a load side is an Average or less.
  - e) During gear life period, the number of times for set of gear engagement is below  $10^7$  times.

(3) To calculate Allowable torque from Allowable transfer capability table (kW) with Bending strength in KG-catalogue.

- 1) Base on Usage Condition of Spur Gear stated above (1) and (2) that obtain a numerical value from Allowable transfer capability table in KG-catalogue.

$$KW=1.61[kW]$$

- 2) Convert to Torque [N.m] from power kW[kW]

$$\text{Gained } T=9549.7 \frac{kW}{n} = 9549.7 \times \frac{1.61}{100} = 153.75[N.m]$$

Therefore selected S2S 38B-2016F as Allowable transfer torque  $T=153.75[N.m]$

This gear can be used unless exceed range of Input torque  $T=153.75[N.m]$

## For example 2. To select KG-STOCK GEARS from usage condition of Spur gear.

(1) Usage condition of Spur gear. (Give us the specification by customer)

- 1) Action to Spur gear with maximum normal torque is  $T=142$  [N.m] included factor of safety.
- 2) The number of revolution  $n=100$  rpm
- 3) Face width of Spur gear  $b=10-30$  [mm]
- 4) Center distance of Spur gear  $a=70-100$  [mm]
- 5) Gear ratio of Spur gear  $u=1:1$
- 6) Providing conditions with usage of gear for strength calculation. Please refer to Calculation for Bending strength of Spur and Helical gears as JGMA401-01.
  - a) The gear is in gearbox with lubricant oil.
  - d) Bearing in gearbox should position on both sides. Bearings are plane symmetry.
  - c) Receiving load from a motor side is a flat load or less.
  - d) Receiving impact from a load side is an Average or less.
  - e) During gear life period, the number of times for set of gear engagement is below  $10^7$  times.

(2) Convert to Power kW [kW] of Allowable transfer capability table with Bending strength from axial torque T [N.m] with action to Spur gear.

$$kW = \frac{T \cdot n}{9549.7} = \frac{142 \times 100}{9549.7} = 1.487 \text{ [kW]}$$

(3) To select KG-STOCK GEARS

- 1) Selected condition of Spur gear.
  - a) Module  $M=2.0$  (eg)
  - b) No. of teeth Center distance  $a=70-100$  [mm]  
Gear ratio  $u=1:1$

Therefore we verify the No. of teeth of 35-50z.

- c) Face width  $b=10-30$  [mm]
- d) The number of revolution  $n=100$  rpm
- e) Power  $kW=1.487$  [kW]

2) Selection of KG STOCK GEARS

- a) Please refer the page for Module 2.0 and Number of teeth 35 to 50 from the catalogue of KG-Spur gear.
- b) Refer to Allowable transfer capability table (kW) of Bending strength.

The number of revolution

Observing the column of  $n=100$  rpm for your selection.

Power

Look up numerical value of  $kW=1.487$  [kW] or more

Concluded,

On condition that Number of teeth:  $z=38$ [z], Face width:  $b=20$  [mm] and material: S45C

Obtained  $kW=1.51$  [kW] from Allowable transfer capability table.

Compared with action to Spur gear with maximum normal torque is  $T=142$  [N.m] included factor of safety.

Can be judged (Allowable transfer capability)  $\geq$  (Normal power).

- c) Can be searched your suitable S2S 38B-2016 as our recommendation only.

### The Conversion formula of Power

1) Calculate Torque from

$T$  : Torque [N · m]

$$T = 9549.7 \frac{kW}{n} \Leftrightarrow kW = \frac{T \cdot n}{9549.7}$$

$T$  : Torque [kgf · m]

$$T = 973.8 \frac{kW}{n} \Leftrightarrow kW = \frac{T \cdot n}{973.8}$$

$T$  : Torque [kgf · m]

$$T = \frac{F_t \cdot r}{1000} \Leftrightarrow F_t = \frac{1000 \cdot T}{r}$$

2) Convert to Standard Integer

$1[\text{kgf} \cdot \text{m}] = 9.80665[\text{N} \cdot \text{m}]$

$1[\text{W}] = 1[\text{N} \cdot \text{m/s}]$

Hereby  $n$  : Revolution per minute rpm

$r$  : Reference radius [mm]

(In case of Shifted gears as working Radius)

$T$  : Torque [N · m]

$kW$  : Power [kW]

$F_t$  : Tangential Force of pitch circle [N]

# 13. Conversion table for SI units (International System of Units)

	N	dyn	kgf
Force	1	$1 \times 10^5$	$1.01972 \times 10^{-1}$
	$1 \times 10^{-5}$	1	$1.01972 \times 10^{-6}$
	9.806 65	$9.80665 \times 10^5$	1

	Pa	bar	kgf/cm <sup>2</sup>	atm	mmH <sub>2</sub> O	mmHg or Torr
Pressure	1	$1 \times 10^{-5}$	$1.01972 \times 10^{-5}$	$9.86923 \times 10^{-6}$	$1.01972 \times 10^{-1}$	$7.50062 \times 10^{-3}$
	$1 \times 10^5$	1	1.01972	$9.86923 \times 10^{-1}$	$1.01972 \times 10^4$	$7.50062 \times 10^2$
	$9.80665 \times 10^4$	$9.80665 \times 10^{-1}$	1	$9.67841 \times 10^{-1}$	$1 \times 10^4$	$7.35559 \times 10^2$
	$1.01325 \times 10^5$	1.01325	1.03323	1	$1.03323 \times 10^4$	$7.60000 \times 10^2$
	9.80665	$9.80665 \times 10^{-5}$	$1 \times 10^{-4}$	$9.67841 \times 10^{-5}$	1	$7.35559 \times 10^{-2}$
	$1.33322 \times 10^2$	$1.33322 \times 10^{-3}$	$1.35951 \times 10^{-3}$	$1.31579 \times 10^{-3}$	$1.35951 \times 10$	1

Note 1Pa=N/m<sup>2</sup>

	Pa	Mpa or N/mm <sup>2</sup>	kfg/mm <sup>2</sup>	kgf/cm <sup>2</sup>
Stress	1	$1 \times 10^{-6}$	$1.01972 \times 10^{-7}$	$1.01972 \times 10^{-5}$
	$1 \times 10^6$	1	$1.01972 \times 10^{-1}$	$1.01972 \times 10$
	$9.80665 \times 10^6$	9.80665	1	$1 \times 10^2$
	$9.80665 \times 10^4$	$9.80665 \times 10^{-2}$	$1 \times 10^{-2}$	1

	Pa·s	cP	P
Coefficient of viscosity	1	$1 \times 10^3$	$1 \times 10$
	$1 \times 10^{-3}$	1	$1 \times 10^{-2}$
	$1 \times 10^{-1}$	$1 \times 10^2$	1

Note 1P = 1dyn·s/cm<sup>2</sup> = 1g/cm·S,  
1Pa·s = 1N·s/m<sup>2</sup>, 1cP = 1mPa·s

## 14. Standardizing the coordination between ISO and JIS

### Introduction

Firstly, as standardizing at the coordination of ISO standard from JIS standard, most of JIS-standard (included Technical report) has been making revision and replacement.

In due time JIS standard and JGMA standard (Japan Gear Manufacturers Association) for the gears shall be revised to a new edition as time to come. However JIS standard and JGMA standard are not complete and some standard was abolished when we started the new edition of KG catalogue. However an old JIS and JGMA standard are essential reference of gears for KG-new catalogue.

Therefore we had adopted the latest JIS and JGMA standard as latest as possible in our new edition KG-catalogue. However if we found inexplicability and nonexistence standard, we introduced the old and new standards to our new edition KG-catalogue.

With respect to the new edition of ISO, JIS and JGMA standards, new edition KG-catalogue is unable to adopt the latest revised ISO, JIS and JGMA standards. We seek your understanding for our latest edition of KG-catalogue.

### Precision of KG STOCK GEARS.

The Two Regulations had enacted that JIS B 1702-1:1998 (Cylindrical gears - Precision and Classification Article 1: Definition of Error and Amount of Permissible for a Gear flank) and JIS B 1702-2:1998 (Cylindrical gears - Precision and Classification Article 2: Error of Tooth to Tooth Working, Definition of Run out and Amount of Precision) in place of JIS B 1702:1995, confirmed (Precision for the Spur and Helical gears) was discontinued after so many years used.

When new JIS compared with old JIS B 1702, the new JIS is unable to be equivalent to the Old JIS class 4 detail, due to different classification of Module and Reference diameter (call Pitch Diameter of old JIS).

The rough outline of the theory is New JIS precision class = Old JIS precision class plus(+) 4, however comparatively range of small or big number of teeth are unable to cover the above classification.

Comparison of new and old gear's terms

JIS B0102 : 1999	Old JIS B0102 : 1993
reference diameter	pitch diameter
tooth depth	whole depth
working tooth depth	working depth
pitch angle	pitch cone angle
tip angle	tip cone angle
root angle	root cone angle
spiral angle	helix angel
locating distance	mounting distance

Some of the old standard still remain unchanged in our new KG-catalogue for the Dimensions of the Gears.

System of accuracy of KG-STOCK GEARS based on JIS B 1702-1 standards are as follows.

Single pitch deviation	JIS B1702-1 class 7
Total cumulative deviation	JIS B1702-1 class 8
Tooth profile deviation	JIS B1702-1 class 8
Run out	JIS B1702-2 class 8 (For reference)

Although we are able to provide the gear with JIS B1702-1 class 8 for tooth profile deviation and runout. In order to maintain the demand so that economically price to be as competitive as possible. Therefore, we manufacturing by equivalent at the JIS B1702-1 class 8 gear.

### Accuracy class of standard gears

Gear type	Series code	Material	Accuracy class
Ground spur gear	SG	SCM435・440	JIS B1702-1 class N5
	SGR	S45C	JIS B1702-1 class N6
Spur gear	S	S45C	JIS B1702-1 class N8
Spur gear / Helical gear	S・H	SUS304	JIS B1702-1 class N9
		Brass ※ 1	JIS B1702-1 class N9
		Poly Acetal	JIS B1702-1 class N9 to N10 ※ 2
Ground spiral miter gear / Ground spiral bevel gear	MG BG	SCM440	JIS B1704 class 1
Ground spiral miter gear	MGE	SCM435・440	JIS B1704 class 2
Straight miter gear / Straight bevel gear	M・B	S45C	JIS B1704 class 3
		S45C (Hardened products)	JIS B1704 class 4
		SUS304	JIS B1704 class 4
		Brass	JIS B1704 class 4
		Poly Acetal	JIS B1704 class 5 to 6 ※ 2

※ 1 Excludes gear-shaped A1 and A2 types.

※ 2 Accuracy at the time of manufacture. Because of the material characteristics, the dimensions and accuracy change with time and due to temperature changes.



# Hardness conversion table

Approximate conversion values compared with Vickers hardness of Steel

Vickers hardness	Brinell hardness 10 mm ball 3000kgf			Rockwell hardness <sup>(2)</sup>				Rockwell superficial hardness diamond cone penetrator			Shore hardness	Tensile strength (Approx. value) MPa (kgf/mm <sup>2</sup> ) <sup>(1)</sup>	Vickers hardness Load
	Standard ball	Hult-gren ball	Tungsten carbide ball	Scale A Load 60kgf Diamond cone penetrator	Scale B Load 100kgf 1/16 inch Ball	Scale C Load 150kgf Diamond cone penetrator	Scale D Load 100kgf Diamond cone penetrator	15-N Scale Load 15 kgf	30-N Scale Load 30 kgf	45-N Scale Load 45 kgf			
940	-	-	-	85.6	-	68.0	76.9	93.2	84.4	75.4	97	-	940
920	-	-	-	85.3	-	67.5	76.5	93.0	84.0	74.8	96	-	920
900	-	-	-	85.0	-	67.0	76.1	92.9	83.6	74.2	95	-	900
880	-	-	(767)	84.7	-	66.4	75.7	92.7	83.1	73.6	93	-	880
860	-	-	(757)	84.4	-	65.9	75.3	92.5	82.7	73.1	92	-	860
840	-	-	(745)	84.1	-	65.3	74.8	92.3	82.2	72.2	91	-	840
820	-	-	(733)	83.8	-	64.7	74.3	92.1	81.7	71.8	90	-	820
800	-	-	(722)	83.4	-	64.0	73.8	91.8	81.1	71.0	88	-	800
780	-	-	(710)	83.0	-	63.3	73.3	91.5	80.4	70.2	87	-	780
760	-	-	(698)	82.6	-	62.5	72.6	91.2	79.7	69.4	86	-	760
740	-	-	(684)	82.2	-	61.8	72.1	91.0	79.1	68.6	84	-	740
720	-	-	(670)	81.8	-	61.0	71.5	90.7	78.4	67.7	83	-	720
700	-	615	(656)	81.3	-	60.1	70.8	90.3	77.6	66.7	81	-	700
690	-	610	(647)	81.1	-	59.7	70.5	90.1	77.2	66.2	-	-	690
680	-	603	(638)	80.8	-	59.2	70.1	89.8	76.8	65.7	80	-	680
670	-	597	630	80.6	-	58.8	69.8	89.7	76.4	65.3	-	-	670
660	-	590	620	80.3	-	58.3	69.4	89.5	75.9	64.7	79	-	660
650	-	585	611	80.0	-	57.8	69.0	89.2	75.5	64.1	-	-	650
640	-	578	601	79.8	-	57.3	68.7	89.0	75.1	63.5	77	-	640
630	-	571	591	79.5	-	56.8	68.3	88.8	74.6	63.0	-	-	630
620	-	564	582	79.2	-	56.3	67.9	88.5	74.2	62.4	75	-	620
610	-	557	573	78.9	-	55.7	67.5	88.2	73.6	61.7	-	-	610
600	-	550	564	78.6	-	55.2	67.0	88.0	73.2	61.2	74	-	600
590	-	542	554	78.4	-	54.7	66.7	87.8	72.7	60.5	-	2055 (210)	590
580	-	535	545	78.0	-	54.1	66.2	87.5	72.1	59.9	72	2020 (206)	580
570	-	527	535	77.8	-	53.6	65.8	87.2	71.7	59.3	-	1985 (202)	570
560	-	519	525	77.4	-	53.0	65.4	86.9	71.2	58.6	71	1950 (199)	560
550	(505)	512	517	77.0	-	52.3	64.8	86.6	70.5	57.8	-	1905 (194)	550
540	(496)	503	507	76.7	-	51.7	64.4	86.3	70.0	57.0	69	1860 (190)	540
530	(488)	495	497	76.4	-	51.1	63.9	86.0	69.5	56.2	-	1825 (186)	530
520	(480)	487	488	76.1	-	50.5	63.5	85.7	69.0	55.6	67	1795 (183)	520
510	(473)	479	479	75.7	-	49.8	62.9	85.4	68.3	54.7	-	1750 (179)	510
500	(465)	471	471	75.3	-	49.1	62.2	85.0	67.7	53.9	66	1705 (174)	500
490	(456)	460	460	74.9	-	48.4	61.6	84.7	67.1	53.1	-	1660 (169)	490
480	448	452	452	74.5	-	47.7	61.3	84.3	66.4	52.2	64	1620 (165)	480
470	441	442	442	74.1	-	46.9	60.7	83.9	65.7	51.3	-	1570 (160)	470
460	433	433	433	73.6	-	46.1	60.1	83.6	64.9	50.4	62	1530 (156)	460
450	425	425	425	73.3	-	45.3	59.4	83.2	64.3	49.4	-	1495 (153)	450
440	415	415	415	72.8	-	44.5	58.8	82.8	63.5	48.4	59	1460 (149)	440
430	405	405	405	72.3	-	43.6	58.2	82.3	62.7	47.4	-	1410 (144)	430
420	397	397	397	71.8	-	42.7	57.5	81.8	61.9	46.4	57	1370 (140)	420
410	388	388	388	71.4	-	41.8	56.8	81.4	61.1	45.3	-	1330 (136)	410
400	379	379	379	70.8	-	40.8	56.0	81.0	60.2	44.1	55	1290 (131)	400
390	369	369	369	70.3	-	39.8	55.2	80.3	59.3	42.9	-	1240 (127)	390
380	360	360	380	69.8	(110.0)	38.8	54.4	79.8	58.4	41.7	52	1205 (123)	380
370	350	350	350	69.2	-	37.7	53.6	79.2	57.4	40.4	-	1170 (120)	370
360	341	341	341	68.7	(109.0)	36.6	52.8	78.6	56.4	39.1	50	1130 (115)	360
350	331	331	331	68.1	-	35.5	51.9	78.0	55.4	37.8	-	1095 (112)	350
340	322	322	322	67.6	(108.0)	34.4	51.1	77.4	54.4	36.5	47	1070 (109)	340
330	313	313	313	67.0	-	33.3	50.2	76.8	53.6	35.2	-	1035 (105)	330

Approximate conversion values compared with Vickers hardness for Steel

Vickers hardness	Brinell hardness 10 mm ball 3000kgf			Rockwell hardness <sup>(2)</sup>				Rockwell superficial hardness diamond cone penetrator			Shore hardness	Tensile strength (Approx. value) MPa (kgf/mm <sup>2</sup> ) <sup>(1)</sup>	Vickers hardness Load
	Standard ball	Hult-gren ball	Tungsten carbide ball	Scale A Load 60kgf Diamond cone penetrator	Scale B Load 100kgf 1/16 inch Ball	Scale C Load 150kgf Diamond cone penetrator	Scale D Load 100kgf Diamond cone penetrator	15-N Scale Load 15 kgf	30-N Scale Load 30 kgf	45-N Scale Load 45 kgf			
320	303	303	303	66.4	(107.0)	33.2	49.4	76.2	52.3	33.9	45	1005 (103)	320
310	294	294	294	65.8	-	31.0	48.4	75.6	51.3	32.5	-	980 (100)	310
300	284	284	284	65.2	(105.5)	29.8	47.5	74.9	50.2	31.1	42	950 (97)	300
295	280	280	280	64.8	-	29.2	47.1	74.6	49.7	30.4	-	935 (96)	295
290	275	275	275	64.5	(104.5)	28.5	46.5	74.2	49.0	29.5	41	915 (94)	290
285	270	270	270	64.2	-	27.8	46.0	73.8	48.4	28.7	-	905 (92)	285
280	265	265	265	63.8	(103.5)	27.1	45.3	73.4	47.8	27.9	40	890 (91)	280
275	261	261	261	63.5	-	26.4	44.9	73.0	47.2	27.1	-	875 (89)	275
270	256	256	256	63.1	(102.0)	25.6	44.3	72.6	46.4	26.2	38	855 (87)	270
265	252	252	252	62.7	-	24.8	43.7	72.1	45.7	25.2	-	840 (86)	265
260	247	247	247	62.4	(101.0)	24.0	43.1	71.6	45.0	24.3	37	825 (84)	260
255	243	243	243	62.0	-	23.1	42.2	71.1	44.2	23.2	-	805 (82)	255
250	238	238	238	61.6	99.5	22.2	41.7	70.6	43.4	22.2	36	795 (81)	250
245	233	233	233	61.2	-	21.3	41.1	70.1	42.5	21.1	-	780 (79)	245
240	228	228	228	60.7	98.1	20.3	40.3	69.6	41.7	19.9	34	765 (78)	240
230	219	219	219	-	96.7	(18.0)	-	-	-	-	33	730 (75)	230
220	209	209	209	-	95.0	(15.7)	-	-	-	-	32	695 (71)	220
210	200	200	200	-	93.4	(13.4)	-	-	-	-	30	670 (68)	210
200	190	190	190	-	91.5	(11.0)	-	-	-	-	29	635 (65)	200
190	181	181	181	-	89.5	( 8.5)	-	-	-	-	28	605 (62)	190
180	171	171	171	-	87.1	( 6.0)	-	-	-	-	26	580 (59)	180
170	162	162	162	-	85.0	( 3.0)	-	-	-	-	25	545 (56)	170
160	152	152	152	-	81.7	( 0.0)	-	-	-	-	24	515 (53)	160
150	143	143	143	-	78.7	-	-	-	-	-	22	490 (50)	150
140	133	133	133	-	75.0	-	-	-	-	-	21	455 (46)	140
130	124	124	124	-	71.2	-	-	-	-	-	20	425 (44)	130
120	114	114	114	-	66.7	-	-	-	-	-	-	390 (40)	120
110	105	105	105	-	62.3	-	-	-	-	-	-	-	110
100	95	95	95	-	56.2	-	-	-	-	-	-	-	100
95	90	90	90	-	52.0	-	-	-	-	-	-	-	95
90	86	86	86	-	48.0	-	-	-	-	-	-	-	90
85	81	81	81	-	41.0	-	-	-	-	-	-	-	85

Remark : Bold figure indicates values from Table 1 of ASTM E 140. (SAE-ASM-ASTM combined and adjusted)

Note : (1) Units and Numerical values in brackets ( ) are converted from psi conversion table of JIS Z 8438 with 1MPa = 1N/ mm<sup>2</sup>

(2) Figures in brackets ( ) from table are seldom used and mainly for reference only.

(3) Iron and Steel quoted from JIS hand book

Approximate converted values compared with Rockwell hardness for Steel (1)

Rockwell Scale C hardness	Vickers hardness	Brinell hardness 10 mm ball 3000kgf			Rockwell hardness <sup>(2)</sup>			Rockwell superficial hardness diamond cone penetrator			Shore hardness	Tensile strength (Approx. value) MPa (kgf/mm <sup>2</sup> ) <sup>(1)</sup>	Rockwell Scale C hardness
		Standard ball	Hult-gren ball	Tungsten carbide ball	Scale A Load 60kgf Diamond cone penetrator	Scale B Load 100kgf 1/16 inch Ball	Scale D Load 100kgf Diamond cone penetrator	15-N Scale Load 15 kgf	30-N Scale Load 30 kgf	45-N Scale Load 45 kgf			
68	940	-	-	-	85.6	-	76.9	93.2	84.4	75.4	97	-	68
67	900	-	-	-	85.0	-	76.1	92.9	83.6	74.2	95	-	67
66	865	-	-	-	84.5	-	75.4	92.5	82.8	73.3	92	-	66
65	832	-	-	(739)	83.9	-	74.5	92.2	81.9	72.0	91	-	65
64	800	-	-	(722)	83.4	-	73.8	91.8	81.1	71.0	88	-	64
63	772	-	-	(705)	82.8	-	73.0	91.4	80.1	69.9	87	-	63
62	746	-	-	(688)	82.3	-	72.2	91.1	79.3	68.8	85	-	62
61	720	-	-	(670)	81.8	-	71.5	90.7	78.4	67.7	83	-	61
60	697	-	613	(654)	81.2	-	70.7	90.2	77.5	66.6	81	-	60
59	674	-	599	(634)	80.7	-	69.9	89.8	76.6	65.5	80	-	59
58	653	-	587	615	80.1	-	69.2	89.3	75.7	64.3	78	-	58
57	633	-	575	595	79.6	-	68.5	88.9	74.8	63.2	76	-	57
56	613	-	561	577	79.0	-	67.7	88.3	73.9	62.0	75	-	56
55	595	-	546	560	78.5	-	66.9	87.9	73.0	60.9	74	2075 (212)	55
54	577	-	534	543	78.0	-	66.1	87.4	72.0	59.8	72	2015 (205)	54
53	560	-	519	525	77.4	-	65.4	86.9	71.2	58.6	71	1950 (199)	53
52	544	(500)	508	512	76.8	-	64.6	86.4	70.2	57.4	69	1880 (192)	52
51	528	(487)	494	496	76.3	-	63.8	85.9	69.4	56.1	68	1820 (186)	51
50	513	(475)	481	481	75.9	-	63.1	85.5	68.5	55.0	67	1760 (179)	50
49	498	(464)	469	469	75.2	-	62.1	85.0	67.6	53.8	66	1695 (173)	49
48	484	451	455	455	74.7	-	61.4	84.5	66.7	52.5	64	1635 (167)	48
47	471	442	443	443	74.1	-	60.8	83.9	65.8	51.4	63	1580 (161)	47
46	458	432	432	432	73.6	-	60.0	83.5	64.8	50.3	62	1530 (156)	46
45	446	421	421	421	73.1	-	59.2	83.0	64.0	49.0	60	1480 (151)	45
44	434	409	409	409	72.5	-	58.5	82.5	63.1	47.8	58	1435 (146)	44
43	423	400	400	400	72.0	-	57.7	82.0	62.2	46.7	57	1385 (141)	43
42	412	390	390	390	71.5	-	56.9	81.5	61.3	45.5	56	1340 (136)	42
41	402	381	381	381	70.9	-	56.2	80.9	60.4	44.3	55	1295 (132)	41
40	392	371	371	371	70.4	-	55.4	80.4	59.5	43.1	54	1250 (127)	40
39	382	362	362	362	69.9	-	54.6	79.9	58.6	41.9	52	1215 (124)	39
38	372	353	353	353	69.4	-	53.8	79.4	57.7	40.8	51	1180 (120)	38
37	363	344	344	344	68.9	-	53.1	78.8	56.8	39.6	50	1160 (118)	37
36	354	336	336	336	68.4	(109.0)	52.3	78.3	55.9	38.4	49	1115 (114)	36
35	345	327	327	327	67.9	(108.5)	51.5	77.7	55.0	37.2	48	1080 (110)	35
34	336	319	319	319	67.4	(108.0)	50.8	77.2	54.2	36.1	47	1055 (108)	34
33	327	311	311	311	66.8	(107.5)	50.0	76.6	53.3	34.9	46	1025 (105)	33
32	318	301	301	301	66.3	(107.0)	49.2	76.1	52.1	33.7	44	1000 (102)	32
31	310	294	294	294	65.8	(106.0)	48.4	75.6	51.3	32.5	43	980 (100)	31
30	302	286	286	286	65.3	(105.5)	47.7	75.0	50.4	31.3	42	950 (97)	30
29	294	279	279	279	64.7	(104.5)	47.0	74.5	49.5	30.1	41	930 (95)	29

CONTENTS  
INFORMATION  
GEARBOXES  
ANTI-BACKLASH SPUR GEARS  
SPUR GEARS  
RACKS  
HELICAL GEARS AND SCREW GEARS  
MITER GEARS  
BEVEL GEARS  
WORMS AND WORM WHEELS  
REFERENCES

## Approximate converted values compared with Rockwell hardness for Steel (1)

Rockwell Scale C hardness	Vickers hardness	Brinell hardness 10 mm ball 3000kgf			Rockwell hardness <sup>(2)</sup>			Rockwell superficial hardness diamond cone penetrator			Shore hardness	Tensile strength (Approx. value) MPa (kgf/mm <sup>2</sup> ) <sup>(1)</sup>	Rockwell Scale C hardness
		Standard ball	Hult-gren ball	Tungsten carbide ball	Scale A Load 60kgf Diamond cone penetrator	Scale B Load 100kgf 1/16 inch Ball	Scale D Load 100kgf Diamond cone penetrator	15-N Scale Load 15 kgf	30-N Scale Load 30 kgf	45-N Scale Load 45 kgf			
28	286	271	271	271	64·3	(104·0)	46·1	73·9	48·6	28·9	41	910 (93)	28
27	279	264	264	264	63·8	(103·0)	45·2	73·3	47·7	27·8	40	880 (90)	27
26	272	258	258	258	63·3	(102·5)	44·6	72·8	46·8	26·7	38	860 (88)	26
25	266	253	253	253	62·8	(101·5)	43·8	72·2	45·9	25·5	38	840 (86)	25
24	260	247	247	247	62·4	(101·0)	43·1	71·6	45·0	24·3	37	825 (84)	24
23	254	243	243	243	62·0	100·0	42·1	71·0	44·0	23·1	36	805 (82)	23
22	248	237	237	237	61·5	99·0	41·6	70·5	43·2	22·0	35	785 (80)	22
21	243	231	231	231	61·0	98·5	40·9	69·9	42·3	20·7	35	770 (79)	21
20	238	226	226	226	60·5	97·8	40·1	69·4	41·5	19·6	34	760 (77)	20
(18)	230	219	219	219	-	96·7	-	-	-	-	33	730 (75)	(18)
(16)	222	212	212	212	-	95·5	-	-	-	-	32	705 (72)	(16)
(14)	213	203	203	203	-	93·9	-	-	-	-	31	675 (69)	(14)
(12)	204	194	194	194	-	92·3	-	-	-	-	29	650 (66)	(12)
(10)	196	187	187	187	-	90·7	-	-	-	-	28	620 (63)	(10)
( 8)	188	179	179	179	-	89·5	-	-	-	-	27	600 (61)	( 8)
( 6)	180	171	171	161	-	87·1	-	-	-	-	26	580 (59)	( 6)
( 4)	173	165	165	165	-	85·5	-	-	-	-	25	550 (56)	( 4)
( 2)	166	158	158	158	-	83·5	-	-	-	-	24	530 (54)	( 2)
( 0)	160	152	152	152	-	81·7	-	-	-	-	24	515 (53)	( 0)

Note : (1) Units and Numerical values in bracket ( ) is converted from psi conversion table of JIS Z 8438 with 1Mpa = 1N/ mm<sup>2</sup>

(2) Figures in brackets ( ) from table are seldom used and mainly for reference only.

(3) Iron and Steel quoted from JIS hand book

# Commonly used fitting tolerances for bore dimensions

Unit :  $\mu\text{m}$

Dimensions (mm)		B		C		D			E			F			G		H					
Above	Below	B10	C9	C10	D8	D9	D10	E7	E8	E9	F6	F7	F8	G6	G7	H6	H7	H8	H9	H10	H11	
-	3	+180 +140	+85 +60	+100	+34	+45 +20	+60	+24	+28 +14	+39	+12	+16 +6	+20	+8 +2	+12	+6	+10	+14	+25	+40	+60	
3	6	+188 +140	+100 +70	+118	+48	+60 +30	+78	+32	+38 +20	+50	+18	+22 +10	+28	+12 +4	+16	+8	+12	+18	+30	+48	+75	
6	10	+208 +150	+116 +80	+138	+62	+76 +40	+98	+40	+47 +25	+61	+22	+28 +13	+35	+14 +5	+20	+9	+15	+22	+36	+58	+90	
10	14	+220	+138	+165	+77	+93	+120	+50	+59	+75	+27	+34	+43	+17	+24	+11	+18	+27	+43	+70	+110	
14	18	+150	+95		+50				+32		+16			+6								
18	24	+244	+162	+194	+98	+117	+149	+61	+73	+92	+33	+41	+53	+20	+28	+13	+21	+33	+52	+84	+130	
24	30	+160	+110		+65				+40		+20			+7								
30	40	+270 +170	+182 +120	+220	+119	+142	+180	+75	+89	+112	+41	+50	+64	+25	+34	+16	+25	+39	+62	+100	+160	
40	50	+280 +180	+192 +130	+230		+80			+50		+25			+9								
50	65	+310 +190	+214 +140	+260	+146	+174	+220	+90	+106	+134	+49	+60	+76	+29	+40	+19	+30	+46	+74	+120	+190	
65	80	+320 +200	+224 +150	+270		+100			+60		+30			+10								
80	100	+360 +220	+257 +170	+310	+174	+207	+260	+107	+126	+159	+58	+71	+90	+34	+47	+22	+35	+54	+87	+140	+220	
100	120	+380 +240	+267 +180	+320		+120			+72		+36			+12								
120	140	+420 +260	+300 +200	+360																		
140	160	+440 +280	+310 +210	+370	+208	+245	+305	+125	+148	+185	+68	+83	+106	+39	+54	+25	+40	+63	+100	+160	+250	
160	180	+470 +310	+330 +230	+390					+85		+43			+14								
180	200	+525 +340	+355 +240	+425																		
200	225	+565 +380	+375 +260	+445	+242	+285	+355	+146	+172	+215	+79	+96	+122	+44	+61	+29	+46	+72	+115	+185	+290	
225	250	+605 +420	+395 +280	+465					+100		+50			+15								
250	280	+690 +480	+430 +300	+510	+271	+320	+400	+162	+191	+240	+88	+108	+137	+49	+69	+32	+52	+81	+130	+210	+320	
280	315	+750 +540	+460 +330	+540		+190			+110		+56			+17								
315	355	+830 +600	+500 +360	+590	+299	+350	+440	+182	+214	+265	+98	+119	+151	+54	+75	+36	+57	+89	+140	+230	+360	
355	400	+910 +680	+540 +400	+630		+210			+125		+62			+18								
400	450	+1010 +760	+595 +440	+690	+327	+385	+480	+198	+232	+290	+108	+131	+165	+60	+83	+40	+63	+97	+155	+250	+400	
450	500	+1090 +840	+635 +480	+730		+230			+135		+68			+20								

Remark : For each cell in the table above, values in the top row shows upper limit of tolerance and values in the bottom row shows lower limit of tolerance.

# Commonly used fitting tolerances for bore dimensions

Unit :  $\mu\text{m}$

Dimensions (mm)		Js				K		M		N		P		R	S	T	U	X
Above	Below	Js6	Js7	Js8	Js9	K6	K7	M6	M7	N6	N7	P6	P7	R7	S7	T7	U7	X7
-	3	$\pm 3$	$\pm 5$	$\pm 7$	$\pm 12.5$	0 -6	0 -10	-2 -8	-2 -12	-4 -10	-4 -14	-6 -12	-6 -16	-10 -20	-14 -24	-	-18 -28	-20 -30
3	6	$\pm 4$	$\pm 6$	$\pm 9$	$\pm 15$	+2 -6	+3 -9	-1 -9	0 -12	-5 -13	-4 -16	-9 -17	-8 -20	-11 -23	-15 -27	-	-19 -31	-24 -36
6	10	$\pm 4.5$	$\pm 7.5$	$\pm 11$	$\pm 18$	+2 -7	+5 -10	-3 -12	0 -15	-7 -16	-4 -19	-12 -21	-9 -24	-13 -28	-17 -32	-	-22 -37	-28 -43
10	14	$\pm 5.5$	$\pm 9$	$\pm 13.5$	$\pm 21.5$	+2	+6	-4	0	-9	-5	-15	-11	-16	-21	-	-26	-33
14	18					-9	-12	-15	-18	-20	-23	-26	-29	-34	-39	-44	-51	-56
18	24	$\pm 6.5$	$\pm 10.5$	$\pm 16.5$	$\pm 26$	+2	+6	-4	0	-11	-7	-18	-14	-20	-27	-	-33	-46
24	30					-11	-15	-17	-21	-24	-28	-31	-35	-41	-48	-54	-61	-77
30	40	$\pm 8$	$\pm 12.5$	$\pm 19.5$	$\pm 31$	+3	+7	-4	0	-12	-8	-21	-17	-25	-31	-39	-51	-
40	50					-13	-18	-20	-25	-28	-33	-37	-42	-50	-59	-64	-76	-86
50	65	$\pm 9.5$	$\pm 15$	$\pm 23$	$\pm 37$	+4	+9	-5	0	-14	-9	-26	-21	-30	-42	-55	-76	-
65	80					-15	-21	-24	-30	-33	-39	-45	-51	-60	-72	-85	-106	-121
80	100	$\pm 11$	$\pm 17.5$	$\pm 27$	$\pm 43.5$	+4	+10	-6	0	-16	-10	-30	-21	-38	-58	-78	-111	-
100	120					-18	-25	-28	-35	-38	-45	-52	-59	-73	-93	-113	-146	-166
120	140	$\pm 12.5$	$\pm 20$	$\pm 31.5$	$\pm 50$	+4	+12	-8	0	-20	-12	-36	-28	-48	-77	-107	-	-
140	160					-21	-28	-33	-40	-45	-52	-61	-68	-88	-117	-147	-159	-171
160	180					-53	-93	-133	-171	-193	-233	-273	-313	-353	-393	-433	-473	-513
180	200	$\pm 14.5$	$\pm 23$	$\pm 36$	$\pm 57.5$	+5	+13	-8	0	-22	-14	-41	-33	-60	-105	-	-	-
200	225					-24	-33	-37	-46	-51	-60	-70	-79	-109	-159	-	-	-
225	250					-67	-123	-173	-223	-273	-323	-373	-423	-473	-523	-573	-623	-673
250	280	$\pm 16$	$\pm 26$	$\pm 40.5$	$\pm 65$	+5	+16	-9	0	-25	-14	-47	-36	-74	-	-	-	-
280	315					-27	-36	-41	-52	-57	-66	-79	-88	-126	-176	-226	-276	-326
315	355	$\pm 18$	$\pm 28.5$	$\pm 44.5$	$\pm 70$	+7	+17	-10	0	-26	-16	-51	-41	-87	-	-	-	-
355	400					-29	-40	-46	-57	-62	-73	-87	-93	-144	-194	-244	-294	-344
400	450	$\pm 20$	$\pm 31.5$	$\pm 48.5$	$\pm 77.5$	+8	+18	-10	0	-27	-17	-55	-45	-103	-	-	-	-
450	500					-32	-45	-50	-63	-67	-80	-95	-108	-166	-216	-266	-316	-366

Remark : For each cell in the table above, values in the top row shows upper limit of tolerance and values in the bottom row shows lower limit of tolerance.

# Commonly used fitting tolerances for axis dimensions

Unit :  $\mu\text{m}$

Dimensions (mm)		js				k		m		n	p	r	s	t	u	x
Above	Below	js5	js6	js7	js8	k5	k6	m5	m6	n6	p6	r6	s6	t6	u6	x6
-	3	$\pm 2$	$\pm 3$	$\pm 5$	$\pm 7$	+4 0	+6	+6 +2	+8	+10 +4	+12 +6	+16 +10	+20 +14	-	+24 +18	+26 +20
3	6	$\pm 2.5$	$\pm 4$	$\pm 6$	$\pm 9$	+6 +1	+9	+9 +4	+12	+16 +8	+20 +12	+23 +15	+27 +19	-	+31 +23	+36 +28
6	10	$\pm 3$	$\pm 4.5$	$\pm 7.5$	$\pm 11$	+7 +1	+10	+12 +6	+15	+19 +10	+24 +15	+28 +19	+32 +23	-	+37 +28	+43 +34
10	14	$\pm 4$	$\pm 5.5$	$\pm 9$	$\pm 13.5$	+9 +1	+12	+15 +7	+18	+23 +12	+29 +18	+34 +23	+39 +28	-	+44 +33	+51 +40
14	18															+56 +45
18	24	$\pm 4.5$	$\pm 6.5$	$\pm 10.5$	$\pm 16.5$	+11 +2	+15	+17 +8	+21	+28 +15	+35 +22	+41 +28	+48 +35	-	+54 +41	+67 +54
24	30													+54 +41	+61 +48	+77 +64
30	40	$\pm 5.5$	$\pm 8$	$\pm 12.5$	$\pm 19.5$	+13 +2	+18	+20 +9	+25	+33 +17	+42 +26	+50 +34	+59 +43	+64 +48	+76 +60	-
40	50													+70 +54	+86 +70	
50	65	$\pm 6.5$	$\pm 9.5$	$\pm 15$	$\pm 23$	+15 +2	+21	+24 +11	+30	+30 +20	+51 +32	+60 +41	+72 +53	+85 +66	+106 +87	-
65	80											+62 +43	+78 +59	+94 +75	+121 +102	
80	100	$\pm 7.5$	$\pm 11$	$\pm 17.5$	$\pm 27$	+18 +3	+25	+28 +13	+35	+45 +23	+59 +37	+73 +51	+93 +71	+113 +104	+146 +124	-
100	120											+76 +54	+101 +79	+126 +104	+166 +144	
120	140	$\pm 9$	$\pm 12.5$	$\pm 20$	$\pm 31.5$	+21 +3	+28	+33 +15	+40	+52 +27	+68 +43	+88 +63	+117 +92	+147 +122	-	-
140	160											+90 +65	+125 +100	+159 +134	-	-
160	180											+93 +68	+133 +108	+171 +146		
180	200	$\pm 10$	$\pm 14.5$	$\pm 23$	$\pm 36$	+24 +4	+33	+37 +17	+46	+60 +31	+79 +50	+106 +77	+151 +122	-	-	-
200	225											+109 +80	+159 +130	-	-	-
225	250											+113 +84	+169 +140			
250	280	$\pm 11.5$	$\pm 16$	$\pm 26$	$\pm 40.5$	+27 +4	+36	+43 +20	+52	+66 +34	+88 +56	+126 +94	-	-	-	-
280	315											+130 +98	-	-	-	-
315	355	$\pm 12.5$	$\pm 18$	$\pm 28.5$	$\pm 44.5$	+29 +4	+40	+46 +21	+57	+73 +37	+98 +62	+144 +108	-	-	-	-
355	400											+150 +114	-	-	-	-
400	450	$\pm 13.5$	$\pm 20$	$\pm 31.5$	$\pm 48.5$	+32 +5	+45	+50 +23	+63	+80 +40	+108 +68	+166 +126	-	-	-	-
450	500											+172 +132	-	-	-	-

Remark : For each cell in the table above, values in the top row shows upper limit of tolerance and values in the bottom row shows lower limit of tolerance.

CONTENTS

INFORMATION

GEARBOXES

ANTI-BACKLASH SPUR GEARS

SPUR GEARS

RACKS

HELICAL GEARS AND SCREW GEARS

MITER GEARS

BEVEL GEARS

WORMS AND WORM WHEELS

REFERENCES

# Commonly used fitting tolerances for axis dimensions

Unit :  $\mu\text{m}$

Dimensions (mm)		b	c	d		e			f			g		h						
Above	Below	b9	c9	d8	d9	e7	e8	e9	f6	f7	f8	g5	g6	h5	h6	h7	h8	h9	h10	h11
-	3	-140 -165	-60 -85	-20 -34 -45		-14 -24 -28 -39			-6 -12 -16 -20			-2 -6 -8		0 -4 -6 -10 -14 -25 -40 -60						
3	6	-140 -170	-70 -100	-30 -48 -60		-20 -32 -38 -50			-10 -18 -22 -28			-4 -9 -12		0 -5 -8 -12 -18 -30 -48 -75						
6	10	-150 -186	-80 -116	-40 -62 -76		-25 -40 -47 -61			-13 -22 -28 -35			-5 -11 -14		0 -6 -9 -15 -22 -36 -58 -90						
10	14	-150 -193	-95 -138	-50		-32			-16			-6		0						
14	18			-77 -93	-50 -59 -75	-27 -34 -43	-14 -17	-8 -11 -18 -27 -43 -70 -110												
18	24	-160 -212	-110 -162	-65		-40			-20			-7		0						
24	30			-98 -117	-61 -73 -92	-33 -41 -53	-16 -20	-9 -13 -21 -33 -52 -84 -130												
30	40	-170 -232	-120 -182	-80		-50			-25			-9		0						
40	50			-119 -142	-75 -89 -112	-41 -50 -64	-20 -25	-11 -16 -25 -39 -62 -100 -160												
50	65	-190 -264	-140 -214	-100		-60			-30			-10		0						
65	80			-146 -174	-90 -106 -134	-49 -60 -76	-23 -29	-13 -19 -30 -46 -74 -120 -190												
80	100	-220 -307	-170 -257	-120		-72			-36			-12		0						
100	120			-174 -207	-107 -126 -159	-58 -71 -90	-27 -34	-15 -22 -35 -54 -87 -140 -220												
120	140	-260 -360	-200 -300	-145		-85			-43			-14		0						
140	160			-208 -245	-125 -148 -185	-68 -83 -106	-32 -39	-18 -25 -40 -63 -100 -160 -250												
160	180	-310 -410	-230 -330	-170		-100			-50			-15		0						
180	200			-242 -285	-146 -172 -215	-79 -96 -122	-35 -44	-20 -29 -46 -72 -115 -185 -290												
200	225	-380 -495	-260 -375	-170		-100			-50			-15		0						
225	250			-242 -285	-146 -172 -215	-79 -96 -122	-35 -44	-20 -29 -46 -72 -115 -185 -290												
250	280	-480 -610	-300 -430	-190		-110			-56			-17		0						
280	315			-271 -320	-162 -191 -240	-88 -108 -137	-40 -49	-23 -32 -52 -81 -130 -210 -320												
315	355	-600 -710	-360 -500	-210		-125			-62			-18		0						
355	400			-299 -350	-182 -214 -265	-98 -119 -151	-43 -54	-25 -36 -57 -89 -140 -230 -260												
400	450	-760 -915	-440 -595	-230		-135			-68			-20		0						
450	500			-327 -385	-198 -232 -290	-108 -131 -165	-47 -60	-27 -40 -63 -97 -155 -250 -400												

Remark : For each cell in the table above, values in the top row shows upper limit of tolerance and values in the bottom row shows lower limit of tolerance.



# Metric coarse and fine screw threads, and reference pilot hole dimensions

Unit : mm

Nominal threads	Pitch				Reference pilot hole dimensions	
	Coarse screw	Fine screw			Coarse screw	Helisert
M1	0.25	0.2			0.75	
M1.1	0.25	0.2			0.85	
M1.2	0.25	0.2			0.95	
M1.4	0.3	0.2			1.1	
M1.6	0.35	0.2			1.25	
M1.8	0.35	0.2			1.45	
M2	0.4	0.25			1.6	2.1
M2.2	0.45	0.25			1.75	2.4
M2.5	0.45	0.35			2.1	2.6
M3	0.5	0.35			2.5	3.1
M3.5	0.6	0.35			2.9	3.7
M4	0.7	0.5			3.3	4.2
M4.5	0.75	0.5			3.8	3.6
M5	0.8	0.5			4.2	5.2
M6	1	0.75			5	6.3
M8	1.25	0.75	1		6.8	8.4
M10	1.5	0.75	1	1.25	8.5	10.5
M12	1.75	1	1.25	1.5	10.3	12.5
M14	2	1	1.25	1.5	12	14.5
M16	2	1	1.5	1.5	14	16.5
M18	2.5	1	1.5	2	15.5	19
M20	2.5	1	1.5	2	17.5	21
M22	2.5	1	1.5	2	19.5	23
M24	3	1	1.5	2	21	25
M27	3	1	1.5	2	24	28
M30	3.5	1	1.5	2	26.5	31

Extracted from JIS B0205, 0207

Following details are for reference only and not part of JIS standard.

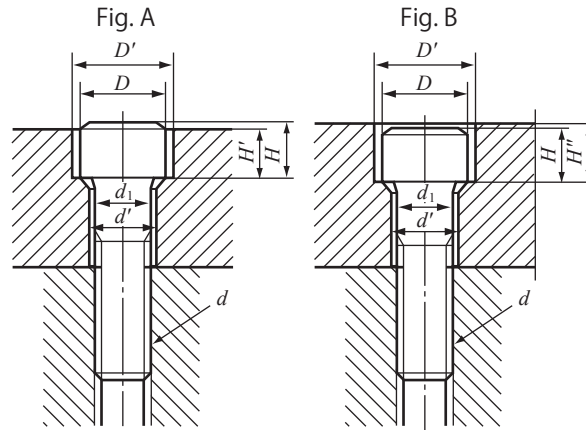

## Spot facing and Thread hole for Hexagon socket head cap screws

Unit: mm

Nominal thread (d)	M3	M4	M5	M6	M8	M10	M12	M14	M16	M18	M20	M22	M24	M27	M30	M33	M36	M39	M42	M45	M48	M52
$d_1$	3	4	5	6	8	10	12	14	16	18	20	22	24	27	30	33	36	39	42	45	48	52
$d'$	3.4	4.5	5.5	6.6	9	11	14	16	18	20	22	24	26	30	33	36	39	42	45	48	52	56
$D$	5.5	7	8.5	10	13	16	18	21	24	27	30	33	36	40	45	50	54	58	63	68	72	78
$D'$	6.5	8	9.5	11	14	17.5	20	23	26	29	32	35	39	43	48	54	58	62	67	72	76	82
$H$	3	4	5	6	8	10	12	14	16	18	20	22	24	27	30	33	36	39	42	45	48	52
$H'$	2.7	3.6	4.6	5.5	7.4	9.2	11	12.8	14.5	16.5	18.5	20.5	22.5	25	28	31	34	37	39	42	45	49
$H''$	3.3	4.4	5.4	6.5	8.6	10.8	13	15.2	17.5	19.5	21.5	23.5	25.5	29	32	35	38	41	44	47	50	54

Remark: Thread holes ( $d'$ ) provide Class 2 from JIS B 1001 (Thread holes and Spot facing holes)

# Shape and dimensions of keyway for parallel key

Cross section of keyway

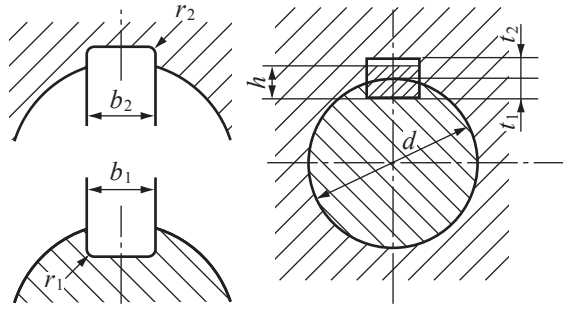

Unit : mm

Normal size of key $b \times h$	Basic dimensions of $b_1$ and $b_2$	Sliding fit		Normal fit		Tight fit	$r_1$ and $r_2$	Basic dimensions of $t_1$	Basic dimensions of $t_2$	Tolerance of $t_1$ and $t_2$	Suitable shaft dia. $d$ (Reference)	Corresponding KG gear bore dia.
		$b_1$	$b_2$	$b_1$	$b_2$	$b_1$ and $b_2$						
		Tolerance (H9)	Tolerance (D 10)	Tolerance (N 9)	Tolerance (Js9)	Tolerance (P9)						
2 × 2	2	+0.025	+0.060	-0.004	± 0.0125	-0.006	0.08 ~ 0.16	1.2	1.0	+0.1 0	6 ~ 8	
3 × 3	3	0	+0.020	-0.029				1.8	1.4		8 ~ 10	8,10
4 × 4	4							2.5	1.8		10 ~ 12	12
5 × 5	5	+0.030	+0.078	0	± 0.0150	-0.012	0.16 ~ 0.25	3.0	2.3	+0.1 0	12 ~ 17	14,15,16
6 × 6	6	0	-0.030	-0.030				3.5	2.8		17 ~ 22	18,20,22
(7 × 7)	7							4.0	3.3		20 ~ 25	
8 × 7	8	+0.036	+0.098	0	± 0.0180	-0.015	0.25 ~ 0.40	4.0	3.3	+0.2 0	22 ~ 30	25,28,30
10 × 8	10	0	+0.040	-0.036				5.0	3.3		30 ~ 38	32,35
12 × 8	12							5.0	3.3		38 ~ 44	40
14 × 9	14	+0.043	+0.120	0	± 0.0215	-0.018	0.40 ~ 0.60	5.5	3.8	+0.2 0	44 ~ 50	45,50
(15 × 10)	15	0	+0.050	-0.043				5.0	5.3		50 ~ 55	
16 × 10	16							6.0	4.3		50 ~ 58	
18 × 11	18						0.40 ~ 0.60	7.0	4.4	+0.2 0	58 ~ 65	
20 × 12	20							7.5	4.9		65 ~ 75	
22 × 14	22	+0.052	+0.149	0	± 0.0260	-0.022		9.0	5.4		75 ~ 85	
(24 × 16)	24	0	+0.065	-0.052			8.0	8.4	80 ~ 90			
25 × 14	25						9.0	5.4	85 ~ 95			
28 × 16	28						10.0	6.4	+0.3 0	95 ~ 110		
32 × 18	32						11.0	7.4		110 ~ 130		
(35 × 22)	35						11.0	11.4		125 ~ 140		
36 × 20	36	+0.062	+0.180	0	± 0.0310	-0.026	0.70 ~ 1.00	12.0	8.4	+0.3 0	130 ~ 150	
(38 × 24)	38	0	+0.080	-0.062				12.0	12.4		140 ~ 160	
40 × 22	40							13.0	9.4		150 ~ 170	
(42 × 26)	42						13.0	13.4	160 ~ 180			
45 × 25	45						15.0	10.4	170 ~ 200			
50 × 28	50						17.0	11.4	200 ~ 230			
56 × 32	56						20.0	12.4	230 ~ 260			
63 × 32	63	+0.074	+0.220	0	± 0.0370	-0.032	1.20 ~ 1.60	20.0	12.4	+0.3 0	260 ~ 290	
70 × 36	70	0	+0.100	-0.072				22.0	14.4		290 ~ 330	
80 × 40	80							25.0	15.4		330 ~ 380	
90 × 45	90	+0.087	+0.260	0	± 0.0435	-0.037	2.00 ~ 2.50	28.0	17.4	+0.3 0	380 ~ 440	
100 × 50	100	0	+0.120	-0.087				31.0	19.5		440 ~ 500	

Based on JIS B 1301

## Parallel key and Key Way

Dimensions and tolerances for KG-gear with Key way are equivalent to JIS B1301.

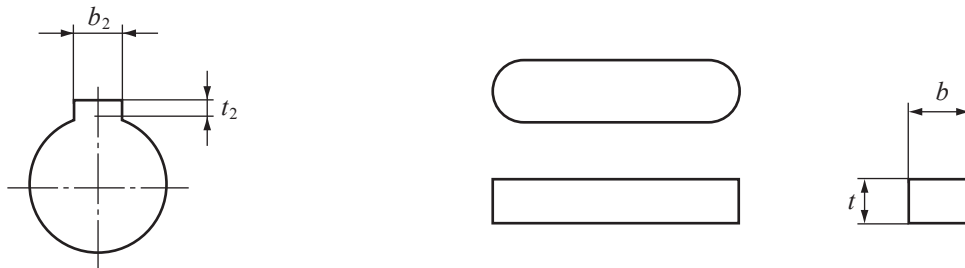

### Tolerances for Key

$b \times t$	3 × 3	4 × 4	5 × 5	6 × 6	8 × 7	10 × 8	12 × 8	14 × 9
$b$ Tolerance (h)	h9	h9	h9	h9	h9	h9	h9	h9
$t$ Tolerance (h)	h9	h9	h9	h9	h11	h11	h11	h11

### Key way for KG-STOCK GEARS

Unit : mm

Dimensions	Bore dimensions	Key way $b_2 \times t_2$	Width		Depth	
			$b_2$	Tolerance Js 9	$t_2$	Tolerance
$\phi 8 \sim \phi 10$	$\phi 8$	3 × 1.4	3	± 0.0125	1.4	+0.1 0
	$\phi 10$					
$\phi 10 \sim \phi 12$	$\phi 12$	4 × 1.8	4	± 0.015	1.8	
$\phi 12 \sim \phi 17$	$\phi 14$	5 × 2.3	5		2.3	
	$\phi 15$					
	$\phi 16$					
$\phi 17 \sim \phi 22$	$\phi 18$	6 × 2.8	6	± 0.018	2.8	
	$\phi 20$					
	$\phi 22$					
$\phi 22 \sim \phi 30$	$\phi 25$	8 × 3.3	8	± 0.0215	3.3	
	$\phi 28$					
	$\phi 30$					
$\phi 30 \sim \phi 38$	$\phi 32$	10 × 3.3	10	± 0.0215	3.3	
	$\phi 35$					
$\phi 38 \sim \phi 44$	$\phi 40$	12 × 3.3	12	± 0.0215	3.3	
$\phi 44 \sim \phi 50$	$\phi 45$	14 × 3.8	14		3.8	
	$\phi 50$					

## Centre bore JIS B1011

Type R

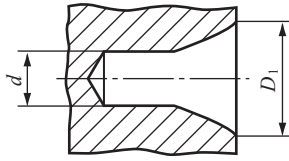

Form with circular arc  
(Drilling centre bore from JIS B4304)

Type A

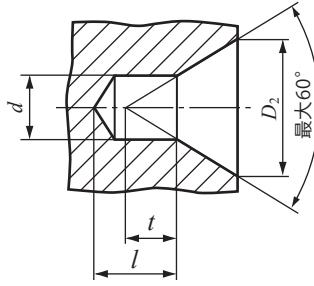

Form without chamfering  
(Drilling centre bore from JIS B4304)

Type B

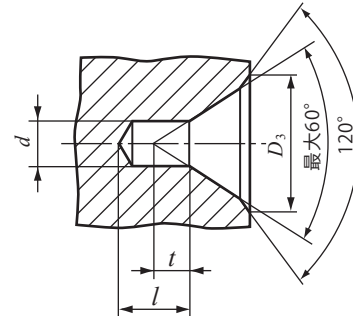

Form with chamfering  
(Drilling centre bore from JIS B4304)

Note\* : Length 'l' is based on centre drill but length must be longer than dimension 't'.

### Centre bore (recommended)

Unit : mm

Nominal $d$	Type				
	Type R JIS B4304	Type A JIS B4304		Type B JIS B4304	
	$D_1$ Nominal	$D_2$ Nominal	$t$ Reference	$D_3$ Nominal	$t$ Reference
(0.5)		1.06	0.5		
(0.63)		1.32	0.6		
(0.8)		1.70	0.7		
1.0	2.12	2.12	0.9	3.15	0.9
(1.25)	2.65	2.65	1.1	4	1.1
1.6	3.35	3.35	1.4	5	1.4
2.0	4.25	4.25	1.8	6.3	1.8
2.5	5.3	5.30	2.2	8	2.2
3.15	6.7	6.70	2.8	10	2.8
4.0	8.5	8.50	3.5	12.5	3.5
(5.0)	10.6	10.60	4.4	16	4.4
6.3	13.2	13.20	5.5	18	5.5
(8.0)	17.0	17.00	7.0	22.4	7.0
10.0	21.2	21.20	8.7	28	8.7

Using figures in bracket ( ) is not advisable.

## C-type retaining ring for shaft (reference)

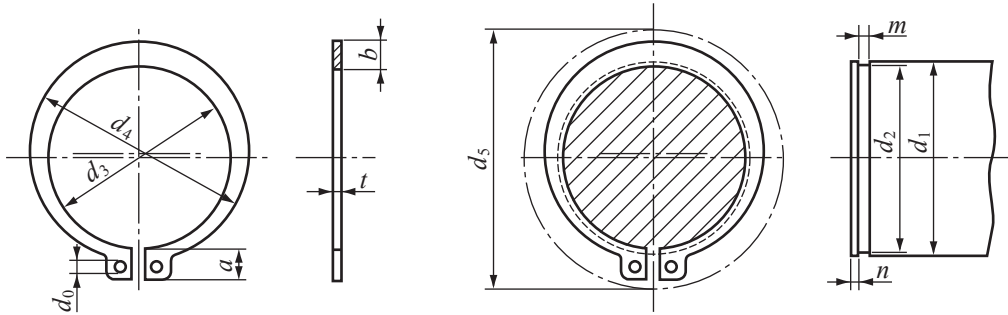

The location of the hole for diameter  $d_0$  should not be hidden by the groove when inserted to a shaft to which the retaining ring is being applied.

$d_5$  is the maximum diameter of the outer circumference when inserting a retaining ring into a shaft.

Unit: mm

Normal diameter		Retaining ring							Applicable shaft (reference)													
1	2	$d_3$		$t$		$b$	$a$	$d_0$ (Min.)	$d_5$	$d_1$	$d_2$		$m$		$n$ (Min.)							
		Basic dimension	Tolerance	Basic dimension	Tolerance						Basic dimension	Tolerance	Basic dimension	Tolerance								
10		9.3	± 0.15	1	± 0.05	1.6	3	1.2	17	10	9.6	0 -0.09	1.15		1.5							
	11	10.2				1.8	3.1		18	11	10.5											
12		11.1	± 0.18			1.2	± 0.06	1.8	3.2	1.7	19	12				11.5	0 -0.11	1.35				
14		12.9						2	3.4		22	14				13.4						
15		13.8						2.1	3.5		23	15				14.3						
16		14.7						2.2	3.6		24	16				15.2						
17		15.7						2.2	3.7		25	17				16.2						
18		16.5						2.6	3.8		26	18				17						
	19	17.5						2.7	3.8		27	19				18						
20		18.5						2.7	3.9		28	20				19						
22		20.5	2.7	4.1	31	22	21															
	24	22.2	± 0.2	1.6	± 0.07	3.1	4.2	2	33	24	22.9	0 -0.21	1.75	+0.14 0	2							
25		23.2				3.1	4.3		34	25	23.9											
	26	24.2				3.1	4.4		35	26	24.9											
28		25.9				3.1	4.6		38	28	26.6											
30		27.9				3.5	4.8		40	30	28.6											
32		29.6				3.5	5		43	32	30.3											
35		32.2				4	5.4		46	35	33											
	36	33.2				± 0.25	1.8		± 0.07	4	5.4					2.5	47	36	34	0 -0.25	1.95	
	38	35.2	4.5	5.6	50			38		36												
40		37	4.5	5.8	53			40		38												
	42	38.5	4.5	6.2	55			42		39.5												
45		41.5	4.8	6.3	58			45		42.5												
	48	44.5	4.8	6.5	62			48		45.5												
50		45.8	5	6.7	64			50		47												
55		50.8	5	7	70			55		52												
	56	51.8	± 0.45	2	± 0.08	5	7	3	71	56	53	0 -0.3	2.2									
60		55.8				5.5	7.2		75	60	57											
65		60.8				6.4	7.4		81	65	62											
70		65.5				6.4	7.8		86	70	67											
75		70.5				7	7.9		92	75	72											
80		74.5				7.4	8.2		97	80	76.5											
85		79.5				8	8.4		103	85	81.5											
90		84.5				8	8.7		108	90	86.5											
95		89.5	± 0.55	3	± 0.09	8.6	9.1	3	114	95	91.5	0 -0.35	3.2	+0.18 0	3							
100		94.5				9	9.5		119	100	96.5											
	105	98				9.5	9.8		125	105	101											
110		103				9.5	10		131	110	106											
120		113				10.3	10.9		143	120	116											
						0	-0.54		4.2													

## C-type retaining ring for hole (reference)

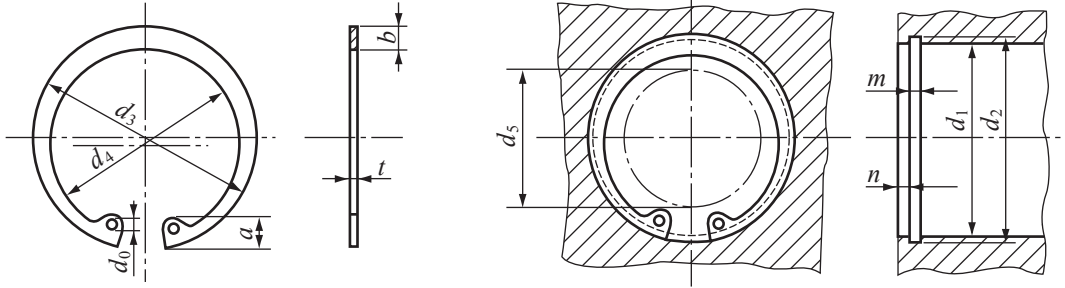

The location of the hole for diameter  $d_0$  should not be hidden by the groove when inserted to a shaft to which the retaining ring is being applied.

$d_5$  is the minimum diameter of the inner circumference when fitting a retaining ring into a hole.

Unit: mm

Normal diameter		Retaining ring							Applicable shaft (reference)						
		$d_3$		$t$		$b$	$a$	$d_0$	$d_5$	$d_1$	$d_2$		$m$		$n$ (Min.)
1	2	Basic dimension	Tolerance	Basic dimension	Tolerance	Approx.	Approx.	Min.			Basic dimension	Tolerance	Basic dimension	Tolerance	
10		10.7	± 0.18	1	± 0.05	1.8	3.1	1.2	3	10	10.4	+ 0.11 0	1.15	1.5	
11		11.8				1.8	3.2	1.5	4	11	11.4				
12		13.0				1.8	3.3	1.7	5	12	12.5				
	13	14.1				1.8	3.5	8	15	15.7					
14		15.1				2.0	3.6	8	16	16.8					
	15	16.2				2.0	3.7	9	17	17.8					
16		17.3				2.0	3.8	10	18	19.0					
	17	18.3				2.5	4.0	11	19	20.0					
18		19.5				2.5	4.0	12	20	21.0					
19		20.5				2.5	4.0	13	22	23.0					
20		21.5	2.5	4.1	± 0.21 0	15	24	25.2	1.35	+ 0.14 0					
22		23.5	2.5	4.3		16	25	26.2							
	24	25.9	3.0	4.4		16	26	27.2							
25		26.9	3.0	4.6		18	28	29.4							
	26	27.9	3.0	4.6		20	30	31.4							
28		30.1	3.0	4.7		21	32	33.7							
30		32.1	3.5	5.2		24	35	37.0							
32		34.4	3.5	5.2		25	36	38.0							
35		37.8	3.5	5.2		26	37	39.0							
	36	38.8	4.0	5.3		27	38	40.0							
37		39.8	4.0	5.7	± 0.25 0	28	40	42.5	1.75	+ 0.14 0					
	38	40.8	4.0	5.8		30	42	44.5							
40		43.5	4.5	5.9		33	45	47.5							
42		45.5	4.5	6.1		34	47	49.5							
45		48.5	4.5	6.2		35	48	50.5							
47		50.5	4.5	6.5		37	50	53.0							
	48	51.5	5.1	6.5		39	52	55.0							
50		54.2	5.1	6.5		41	55	58.0							
52		56.2	5.1	6.6		42	56	59.0							
55		59.2	5.5	6.8		46	60	63.0							
	56	60.2	5.5	6.9	48	62	65.0								
60		64.2	5.5	6.9	49	63	66.0								
62		66.2	5.5	7.0	50	65	68.0								
	63	67.2	6.0	7.4	53	68	71.0								
68		72.5	6.0	7.4	55	70	73.0								
	70	74.5	6.6	7.4	57	72	75.0								
72		76.5	6.6	7.4	60	75	78.0								
75		79.5	7.0	8.0	64	80	83.5								
80		85.5	7.0	8.0	69	85	88.5								
85		90.5	7.6	8.3	73	90	93.5								
90		95.5	8.0	8.5	77	95	98.5								
95		100.5	8.3	8.8	82	100	103.5								
100		105.5	8.9	9.1	86	105	109.0								
	105	112.0	8.9	10.2	89	110	114.0								
110		117.0	8.9	10.2	90	112	116.0								
	112	119.0	9.5	10.2	94	115	119.0								
	115	122.0	9.5	10.7	98	120	124.0								
120		127.0	10.0	10.7	103	125	129.0								
125		132.0													

## E-type retaining ring (reference)

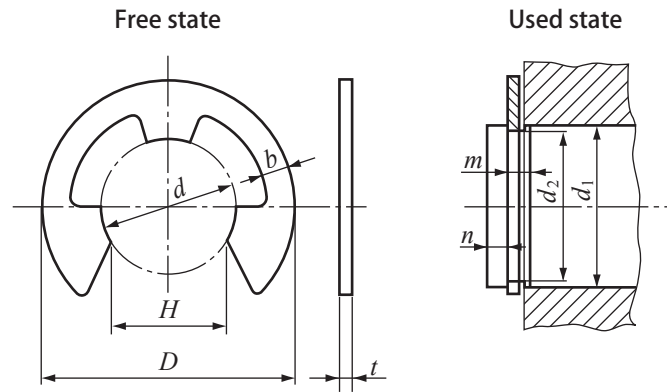

Example shape

Unit: mm

Normal diameter	Retaining ring										Applicable shaft (reference)						
	d		D		H		t		b		Division of d <sub>1</sub>		d <sub>2</sub>		m		n (Min.)
	Basic dimension	Tolerance	Basic dimension	Tolerance	Basic dimension	Tolerance	Basic dimension	Tolerance	Approx.	Above	Below	Basic dimension	Tolerance	Basic dimension	Tolerance		
0.8	0.8	0 -0.08	2	± 0.1	0.7	0 -0.25	0.2	± 0.02	0.3	1	1.4	0.8	+0.05 0	0.3	+0.05 0	0.4	
1.2	1.2	0 -0.09	3	± 0.2	1		0.3	± 0.025	0.4	1.4	2	1.2	+0.06 0	0.4		+0.1 0	0.6
1.5	1.5		4		1.3		0.4	± 0.03	0.6	2	2.5	1.5		0.5			0.8
2	2		5		1.7	0.4	± 0.04	0.7	2.5	3.2	2	0.7		+0.075 0	+0.14 0		1
2.5	2.5	6	2.1	0.4	± 0.05	0.8	3.2	4	2.5	0.8	+0.09 0	2					
3	3	7	2.6	0.6		0.9	4	5	3	0.7							
4	4	9	3.5	0.6		1.1	5	7	4	0.9							
5	5	0 -0.12	11	± 0.3	4.3	0 -0.3	0.6	± 0.06	1.2	6	8	5	+0.11 0	1.15	+0.14 0	1.2	
6	6	12	5.2		0.8	1.4	7		9	6	1.5						
7	7	14	6.1		0.8	1.6	8		11	7	1.8						
8	8	0 -0.15	16	± 0.3	6.9	0 -0.35	0.8	± 0.05	1.8	9	12	8	+0.13 0	1.75	+0.14 0	1.8	
9	9	18	7.8		0.8		2		10	14	9	2					
10	10	20	8.7		1		2.2		11	15	10	2.5					
12	12	0 -0.18	23	± 0.3	10.4	0 -0.45	1	± 0.06	2.4	13	18	12	+0.13 0	2.2	+0.14 0	2.5	
15	15	29	13		1.6		2.8		16	24	15	3					
19	19	37	16.5		1.6		4		20	31	19	3.5					
24	24	0 -0.21	44	± 0.3	20.8	0 -0.5	2	± 0.07	5	25	38	24	0	2.2	4		

## Explanation of material notation

Explanation of material notation for KG standard products		
Material grade	Types of KG standard gears used	Material name / Standard number
S45C	Spur gear, Helical gear, Rack gear, Miter gear / Bevel gear (straight / spiral), B-LOCK Miter gear (straight), Worm, Anti-backlash spur gear	Carbon steel JIS G 4051
SCM435 SCM440	Ground spur gear, Ground miter gear / Ground bevel gear (spiral), Anti-backlash ground spur gear, Anti-backlash spur gear	Chrome molybdenum steel JIS G 4053
SUS304 SUS304L	Spur gear, Helical gear, Rack gear, Miter gear / Bevel gear (straight), MIM (metal injection molding) miter gear, B-LOCK miter gear (straight), Worm, Anti-backlash spur gear	Stainless steel JIS G 4303
C3604B C3771B C3713P	Spur gear, Rack gear, Miter gear / Bevel gear (straight), Worm	Brass JIS H 3250 JIS H 3100
C6191BE	Worm Wheel	Aluminum bronze JIS H 3250
CAC702	Worm Wheel	Aluminum bronze casting JIS H 5120
A5056	Anti-backlash spur gear	Aluminum JIS H 4040
POM (Polyacetal)	Spur gear, Helical gear, Rack gear, Miter gear (straight), Worm Wheel	Acetal resin

KG standard gears are manufactured using the above JIS materials. Depending on availability, the above materials may be substituted with materials of equivalent specifications without prior notice.

The chemical composition may differ from other standards, so the above information is just for reference purposes. Please note that some products have surface treatments such as black oxide and alumite treatment.

Parts other than gears, such as springs and retaining rings for anti-backlash spur gears, gear box bodies and bearings, set screws, cap bolts, etc., are excluded.





Edited and Published by KYOUIKU GEAR MFG.CO.,LTD.

URL: <http://www.kggear.co.jp/en/>

For Inquiries: [export@kggear.co.jp](mailto:export@kggear.co.jp)



- Head Office            1-8-3,Higashi-ueno Taito-ku Tokyo Japan.110-0015
- Tokyo branch        4-13-21-3F,Taito Taito-ku Tokyo Japan.110-0016  
TEL : (81)-3-5812-4337    FAX : (81)-3-5812-4339
- Overseas Sales Department    TEL : (81)-3-5812-4338
- Osaka branch        9F SC Sakaisuji Honmachi Bld  
1-4-15,Kita-kyuhoujimachi Chuo-ku Osaka-city Japan.541-0057  
TEL : (81)-6-4705-8177    FAX : (81)-6-4705-8188
- Nagoya branch      2-24-9,Ichiban Atsuta-ku Nagoya-city Aichi Japan.456-0053  
TEL : (81)-52-652-7211    FAX : (81)-52-652-7213
- Factory                14-9-13,Minami-sakaemachi Kasukabe-city Saitama Japan.344-0057  
TEL : (81)-48-754-5842    FAX : (81)-48-754-1299

## KYOUIKU GEAR MFG.CO.,LTD.

First Edition :18th Jun 2024

Attach your Company Seal Here



Kasukabe Factory  
Tokyo branch  
Overseas Sales department  
Osaka branch  
Nagoya branch



Kasukabe Factory